

Sixth Semester
B.Sc. Degree Programme
UNIVERSITY OF CALICUT

Manjusha

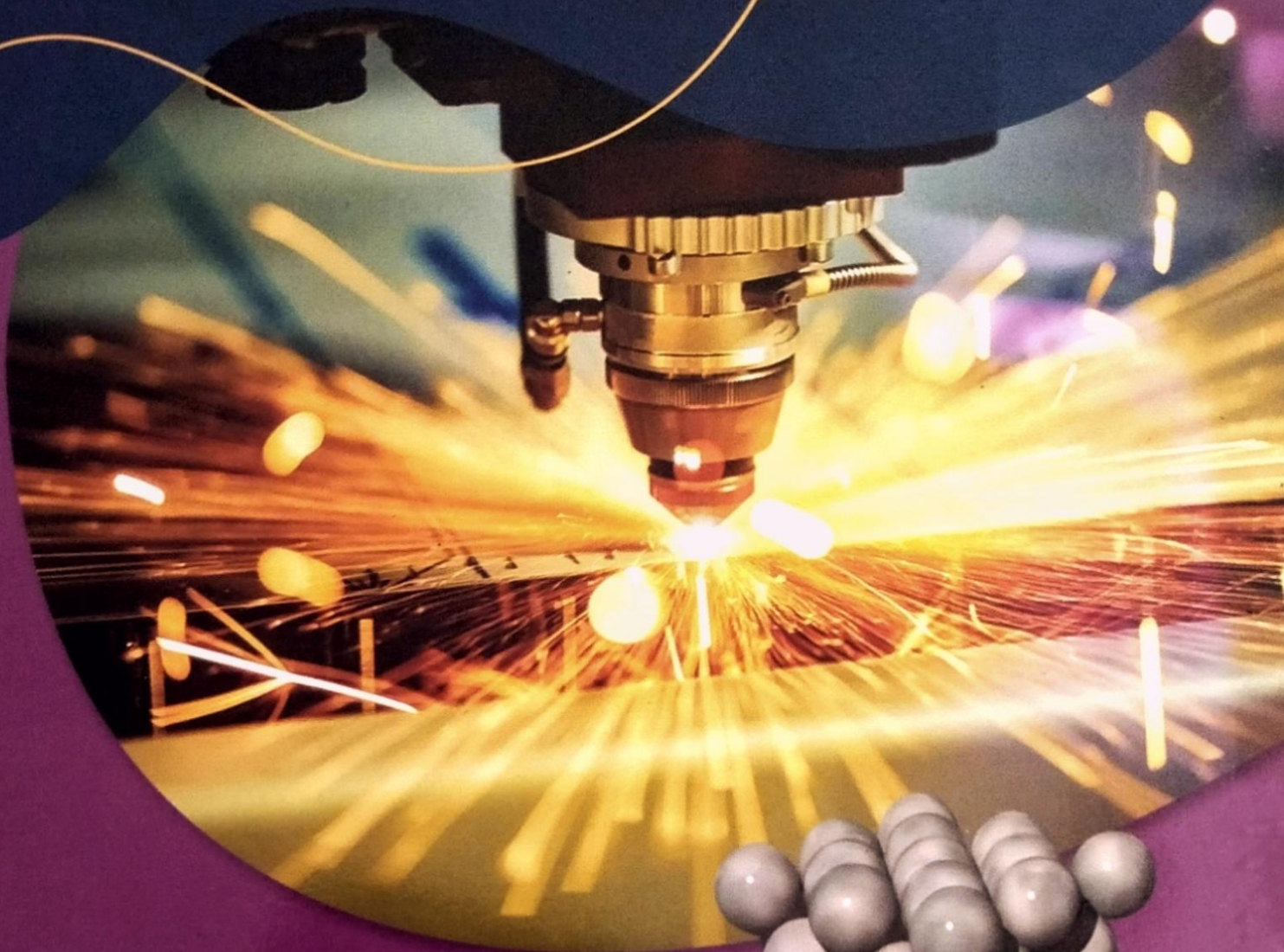

Core Course PHYSICS

Statistical Physics
Solid State Physics
Spectroscopy and Photonics



Dr. P.Sethumadhavan

1

STATISTICAL PHYSICS

Introduction

Statistical mechanics is the science of predicting the observable properties of a many body system by studying the statistics of the behaviour of its individual constituents like atoms, molecules, photons, electrons, phonons, quarks etc. Thus with the help of statistical mechanics we are able to explain the following:

1. Thermionic emission
2. Photoelectric effect
3. Black body radiation
4. Stellar properties
5. All stars, neutron stars, white dwarfs etc.
6. Thermal and electric properties of solids. (Thermal conductivity, specific heat of solids, electrical conductivity etc.)
7. Magnetic properties of materials. (Dia, Para, ferro, susceptibility etc.)

The very name statistical mechanics implies that it is not concerned with the actual motions or interactions of individual particle but instead with what is most likely to happen. It never tells us the history of one of the particles of the system but it tells us the probability that the particle has a certain amount of energy at a certain moment. Statistical mechanics can be applied to classical systems (molecules in a gas) as well as to quantum mechanical systems (electrons, photons etc.)

Statistical analysis

In physics many of the experiments are analysed as if the interactions takes place in single, isolated events. For example in Rutherford scattering and Compton scattering experiments treated the events as single and isolated. Suppose we consider another simple experiment that we supply heat energy to a gas constituting large number of particles (atoms). The energy that we supply will go to all the particles. Here the system cannot be treated as a single entity (or event). At the same time we cannot analyse the behaviour of individual atoms which are millions of millions in number. Such systems could be analysed by the technique of statistical mechanics. That is statistical mechanics deals with the collective behaviour of the system. In this analysis we are not concerned with or not possible to have the exact outcome of single particle. But statistical mechanics predicts the average outcome of the collec-

tive behaviour of particles or events based on the statistical distribution of all the possible outcomes. The above discussion shows that whenever a system containing large number of particles the concept of statistical mechanics is necessary.

Apart from the simple experiment quoted above there are so many complex systems that contain large number of particles such as the spectrum given out by mercury vapour while passing electric current through it and the thermionic emission of tungsten filament of an ordinary incandescent light bulb etc. In the case of spectrum millions of photons take part in the process and in the case of thermionic emission millions of electrons take part. How do we analyse such complex systems which contain infinitely large number of particles. Statistical analysis provides the exact prediction of the output. Here we discuss how statistical analysis is done.

It may seem that there are two possible ways to approach the analysis of a complex system. First is to specify a set of microscopic properties such as position and velocity of each atom. Even for a pinch of matter contains very large number of particles (Avogadro number 6.02×10^{23} per mole). Assigning positions and velocities to 10^{23} atoms and then to proceed is an impossible task. The second approach is understanding and predicting the behaviour of systems containing many particles in terms of a few macroscopic properties such as the pressure, temperature etc. The development of relationship between microscopic and macroscopic properties was one of greatest achievements, which plays a crucial role in the development of statistical mechanics.

Macroscopic property of a system

It is the behaviour exhibited by the system at macroscopic level. Pressure, temperature, energy are some of the macroscopic properties of gas. These properties are observable and can be measured.

Microscopic property of a system

It is the behaviour exhibited by individual constituents of the system or it is the behaviour of the system at microscopic level.

Macrostate and microstate

Consider the macroscopic property energy (E) of the system. This energy is due to the contributions coming from individual particles. Thus the energy (E) of the system can be achieved in different possible ways of energy distributions of individual particles. Each possible arrangement is called the macrostate of the system. In each macrostate a number of different arrangements of particles is possible to get the same energy E . Each different arrangement is known as the microstate of the system. This can be clarified by taking examples.

Consider the distribution of 2 units of energy to a system (gas) containing four identical but distinguishable particles. A, B, C and D. Assume that each particle can acquire energy only in integral units.

Macrostate	Energy of the particle				Total energy
	A	B	C	D	
Macrostate I	2	0	0	0	2
Macrostate II	1	1	0	0	2

Thus our system has only two macrostates.

But in macrostate we can distribute energy among particles in different ways.

Macrostate	Energy of the particle				Total energy
	A	B	C	D	
Macrostate I	2	0	0	0	2
	0	2	0	0	2
	0	0	2	0	2
	0	0	0	2	2

Thus we have 4 possible arrangements in macrostate I. That is Macrostate I has four possible microstates.

Macrostate	Energy of the particle				Total energy
	A	B	C	D	
Macrostate II	1	1	0	0	2
	1	0	1	0	2
	1	0	0	1	2
	0	1	1	0	2
	0	0	1	1	2
	0	1	0	1	2

Here we have 6 possible arrangements in the macrostate II. That is macrostate II has 6 microstates.

The number of microstates in a given macrostate is called multiplicity denoted by W . In our system

$$W_1 = 4 \text{ and } W_2 = 6.$$

By counting the number of microstates we can make a statistical analysis.

One application of the counting of multiplicity is to determine the direction of the natural evolution of the system. According to second law of thermodynamics an

isolated systems evolve in a direction of increasing entropy, our system evolves along the direction of multiplicity. Thus we can say that when multiplicity increases entropy of the system also increases. That is, if we started our system in the microstate I and allowed the particles to interact with one another, after sometime the system would be in the macrostate II. If the system is in the macrostate II after sometime, the system is less likely to find in macrostate I. This is because multiplicity decreases in going from macrostate II to I as the natural system evolves along the direction of multiplicity.

In the above statistical analysis there is an implicit postulate.

That is "all microstates are equally probable".

In our system considered there are totally 10 (4 + 6) microstates. According to the postulate our system can be found with equal probability in any of the 10 microstates. Since there are 6 microstates in macrostate II and 4 microstates in macrostate I, the system is more likely to be found in macrostate II. This probability is obviously

$\frac{6}{10} = 60\%$. Thus the probability of finding the system in the macrostate I is

$\frac{4}{10} = 40\%$. i.e., The system is found in the macrostate I with 40% probability and in

macrostate II with 60% probability.

This shows that the above said postulate enables us to calculate the probability of occurrence of the system in different macrostates. (see examples 1 and 2).

We can conclude this section by saying that the statistical analysis of a complex system gives us a way of describing the system, its average properties and its evolution in time.

Example 1

- Considering the numbers of heads and tails, how many macrostates are there when 4 coins are tossed.
- What is the total number of possible microstates in tossing 4 coins.
- Find the total number of microstates for each macrostate.

Solution

- When 4 coins are tossed there are 5 different distributions. They are (0H, 4T), (1H, 3T), (2H, 2T), (3H, 1T) and (4H, 0T) so we have five macrostates.
- To find the total number microstates, we have to find out all possible distributions in each macrostate. See the table below.

	Macrostate		Microstate	Number of microstates W
	Head (↑)	Tail (↓)		
1)	0	4	↓↓↓↓	1
2)	1	3	↑↓↓↓	4
			↓↑↓↓	
			↓↓↑↓	
			↓↓↓↑	
3)	2	2	↑↑↓↓	6
			↑↓↑↓	
			↓↑↓↑	
			↓↑↑↓	
			↓↓↑↑	
			↑↓↓↑	
4)	3	1	↑↑↑↓	4
			↑↑↓↑	
			↑↓↑↓	
			↓↑↑↑	
5)	4	0	↑↑↑↑	1

∴ Total number of microstates = 1 + 4 + 6 + 4 + 1 = 16

or Each toss has 2 possible outcomes, so
 the total number of possible outcomes = $2^4 = 16$

Example 2

A collection of three non-interacting particles shares 3 units of energy. Each particle is restricted to having an integral number of units of energy.

- (a) How many macrostates are there?
 (b) How many microstates are there in each of the macrostates
 (c) What is the probability of finding one of the particles with 2 units of energy?
 With 0 units of energy?

Solution

	A	B	C	Total energy
a) Macrostates 1	3	0	0	3
Macrostate 2	2	1	0	3
Macrostate 3	1	1	1	3

Thus there are 3 macrostates.

- b) In macrostate 1, there are 3 different ways of arrangements

A	B	C
3	0	0
0	3	0
0	0	3

In macrostate 2

A	B	C
2	1	0
2	0	1
1	2	0
1	0	2
0	1	2
0	2	1

So there are 6 microstates.

In macrostate 3	A	B	C
	1	1	1

There is only one possible arrangement, so there is only one microstate.

- c) There are totally $3 + 6 + 1 = 10$ microstates.

The probability of occurrence of 2 units of energy in macrostate 1 is zero, because none of the particles in macrostate 1 has 2 units of energy.

In macrostate 2, there are 6 microstates.

\therefore Probability of the macrostate 2

$$= \frac{6}{10} = 60\%.$$

Only one of the particles in macrostate 2 has 2 units of energy.

∴ Probability of finding one of the particles with energy 2 units

$$= \frac{1}{3} \times \frac{6}{10} = 0.2 = 20\%.$$

None of the particles has 2 unit of energy in the macrostate 3.

∴ Overall probability = $\frac{0}{3} \times \frac{3}{10} + \frac{1}{3} \times \frac{6}{10} + \frac{0}{3} \times \frac{1}{10} = 20\%$.

0 units of energy probability

The probability of finding one of the particles in the macrostate 1

$$= \frac{2}{3} \times 30\% = 20\%.$$

$$\text{In macrostate 2} = \frac{1}{3} \times 60\% = 20\%$$

In macrostate 3 none of the particles has 0 unit of energy, so probability = 0

∴ Overall probability = 40%.

Generalisation of probability

We have from (c) of the example 2

$$P(\varepsilon = 2) = \frac{0}{3} \times \frac{3}{10} + \frac{1}{3} \times \frac{6}{10} + \frac{0}{3} \times \frac{1}{10}$$

Generalising this result, we get

$$P(\varepsilon) = \frac{N_1}{N} \frac{W_1}{W_{\text{total}}} + \frac{N_2}{N} \frac{W_2}{W_{\text{total}}} + \frac{N_3}{N} \frac{W_3}{W_{\text{total}}}$$

Where N_1 is the number of particles with energy ε , in the first macrostate 1 with multiplicity W_1 and W_{total} is the overall total multiplicity.

N_2 is the number of particles with energy ε , in the macrostate 2 with multiply W_2 . Similarly W_3 is the number of particles with energy ε in the macrostate 3 with multiplicity W_3 . In general we can write.

$$P(\epsilon) = \frac{\sum_i N_i W_i}{N \sum_i W_i} \dots (1)$$

where i runs over all the macrostates.

Classical and quantum statistics

In classical statistics particles are identical but distinguishable whereas in quantum statistics particles are treated as identical but indistinguishable. It is due to this difference the multiplicity and the probability will be different in the two regimes. By taking a simple example we can illustrate this.

Classical

Consider the distribution of 6 units of energy to a system containing only 5 identical but distinguishable particles. Assume that these particles can acquire energy only in integral units and also acquire 0 unit of energy.

Here there are 10 macrostates (see tabular column below)

Energy of the particles (Table I)

Macrostates	0	1	2	3	4	5	6	Total energy
1	4	0	0	0	0	0	1	6
2	3	1	0	0	0	1	0	6
3	3	0	1	0	1	0	0	6
4	2	2	0	0	1	0	0	6
5	2	1	1	1	0	0	0	6
6	3	0	0	2	0	0	0	6
7	2	0	3	0	0	0	0	6
8	1	3	0	1	0	0	0	6
9	1	2	2	0	0	0	0	6
10	0	4	1	0	0	0	0	6

We obtained 10 macrostates. The multiplicity of each microstate in the macrostate can be calculated as before. That method of finding the number of microstates by drawing tabular column is laborious and time consuming. So to evaluate the number of microstate (multiplicity W) we introduce a formula

$$W = \frac{N!}{N_0! N_1! N_2! N_3! N_4! N_5! N_6!} \dots (2)$$

Where N is the total number of particles and $N_0, N_1, N_2, N_3, N_4, N_5, N_6$ are the number of particles with energies 0, 1, 2, 3, 4, 5, and 6 respectively. In general

$$W = \frac{N!}{\prod_{i=0}^6 N_i} \quad \dots (3)$$

Remember that

$$N_0 + N_1 + N_2 + N_3 + N_4 + N_5 + N_6 = N$$

$$\text{and } 0 \times N_0 + 1 \times N_1 + 2 \times N_2 + 3 \times N_3 + 4 \times N_4 + 5 \times N_5 + 6 \times N_6 = \text{Total energy}$$

For example, in the macrostate 1

$$N_0 = 4, N_1 = 0, N_2 = 0, N_3 = 0, N_4 = 0, N_5 = 0 \text{ and } N_6 = 1$$

$$\therefore N = 5$$

$$W_1 = \frac{5!}{4! 1!} = \frac{1.2.3.4.5}{1.2.3.4} = 5$$

Similarly we can calculate all multiplicities

$$W_2 = 20$$

$$W_3 = 20$$

$$W_4 = 30$$

$$W_5 = 60$$

$$W_6 = 10$$

$$W_7 = 10$$

$$W_8 = 20$$

$$W_9 = 30$$

$$W_{10} = 5$$

\therefore The overall total number of microstates

$$W_{\text{total}} = 5 + 20 + 20 + 30 + 60 + 10 + 10 + 20 + 30 + 5$$

$$W_{\text{total}} = 210.$$

When there are N particles share Q integral units of energy.

$$W_{\text{total}} = \frac{(N+Q-1)!}{Q! (N-1)!} \quad \dots (4)$$

In our problem $N = 5, Q = 6$

$$\therefore W_{\text{total}} = \frac{(5+6-1)!}{6! 4!} = \frac{10!}{6! 4!} = 210.$$

We already calculated the general expression for the probability of finding one of particles with energy ϵ .

$$\text{i.e., } P(\epsilon) = \frac{\sum_i N_i W_i}{N \sum_i W_i} \dots (5)$$

i runs over all macrostates. ($i = 1$ to 10)

$$P(0) = \frac{5 \times 5 + 4 \times 20 + 4 \times 20 + 4 \times 30 + 3 \times 60 + 5 \times 10 + 5 \times 10 + 4 \times 20 + 4 \times 30 + 5 \times 5}{10 \times 210}$$

$$P(0) = \frac{25 + 80 + 80 + 120 + 180 + 50 + 50 + 80 + 120 + 25}{2100}$$

$P(0) = 0.4$ similarly, we get

$$P(1) = 0.267 \qquad P(5) = 0.019$$

$$P(2) = 0.167 \qquad P(6) = 0.005$$

$$P(3) = 0.095$$

$$P(4) = 0.048$$

Summing all the probabilities over all energy states we get unity.

$$\text{i.e., } \sum_{i=0}^6 P(\epsilon_i) = 1$$

When we draw a graph between energy along the x-axis and probability $P(\epsilon)$ along the y-axis, we get a graph as shown in figure below.

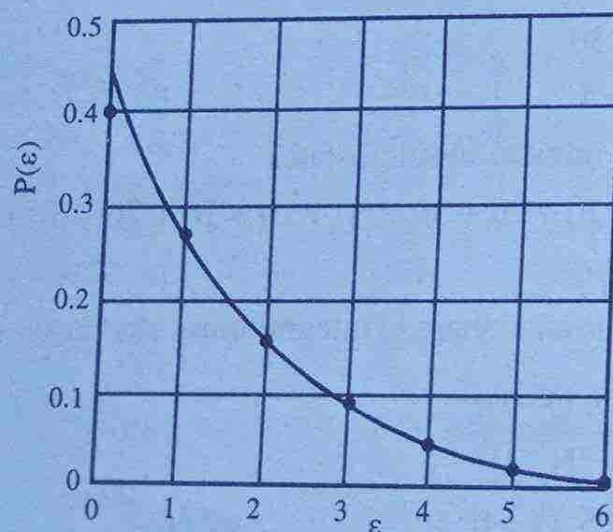

Figure 1.1: Probability graph
(The curve is an exponential function that closely fits the points)

The smooth curve obtained is an exponentially decreasing curve.

i.e., $P(\epsilon) \propto e^{-\beta\epsilon}$

Where β is a constant to be chosen to fit the curve.

The whole discussion shows that for classical particle the probability distribution is an exponential function.

Note : $P(\epsilon_i) = A^{-1}e^{-\beta\epsilon_i}$

Summing over all energy states, we get

$$\sum P(\epsilon_i) = A^{-1} \sum_{i=1} e^{-\beta\epsilon_i}$$

But $\sum_i P(\epsilon_i) = 1$

$\therefore 1 = A^{-1} \sum_{i=1} e^{-\beta\epsilon_i}$

or $A^{-1} = \frac{1}{\sum_{i=1} e^{-\beta\epsilon_i}}$

$\therefore P(\epsilon_i) = \frac{e^{-\beta\epsilon_i}}{\sum_{i=1} e^{-\beta\epsilon_i}} \dots (6)$

Quantum statistics

In quantum mechanics particles are treated as identical and indistinguishable. So while enumerating the multiplicity in quantum statistics it will be different from that of classical statistics. For example consider a macrostate in classical statistics. The classical system containing three distinguishable particles A, B and C with energies 2, 1 and 3 units respectively with total energy 6 units. Here we consider only one macrostate.

i.e., Macrostate is

A	B	C
2	1	3

These energies 2, 1 and 3 can be distributed to the particles A, B and C in different ways. The number of different arrangements gives the number of microstates (multiplicity)

i.e.,

A	B	C	
2	1	3	}
1	2	3	
2	3	1	
1	3	2	
3	1	2	
3	2	1	

6 numbers

Thus the number of microstates (multiplicity) in the particular macrostate is 6.

In quantum statistics particles are indistinguishable. So $A = B = C \equiv A$

∴ The corresponding macrostate in quantum statistics for the above example is

A	A	A
2	1	3

Here no more different arrangements of distributing energies to particles is possible. Hence the number of microstate (multiplicity) is one.

If you take any other macrostate, the corresponding number of state is always one. Thus, we can say that for identical indistinguishable (quantum) particles the multiplicity of each macrostate is always one.

Another important restriction imposed by quantum particles is the accommodation of number particles in each state. For example suppose we deal with electrons

(spin $\frac{1}{2}$). According to Pauli's exclusion principle a state can accommodate a maximum

of two electrons with different quantum numbers, say one spin up ($m_s = \frac{1}{2}$)

the other one spin down ($m_s = -\frac{1}{2}$). This number is governed by the rule $(2s + 1) =$

2. If we are dealing with spin 1 particles the total number of particles that a state can accommodate = $(2 \times 1 + 1) = 3$. Remember that this rule is applicable only to fermions.

The restriction on the number particle on the states brings change in the number of macrostates.

Fore example consider the distribution of 6 units of energy to a system containing 5 particles. If the particles are classical, we could see that there are totally 10

macrostates possible (see tabular column p. 12). If the particles are electrons each energy state can accommodate only two electrons. Thus in the tabular column macrostates 1, 2, 3, 6, 7, 8 and 10 are forbidden. That is the possible number of macrostates is only $(10 - 7) = 3$.

Finally we calculate the probability $P(\epsilon)$ in quantum statistics and their functional form.

$$\text{We have } P(\epsilon) = \frac{\sum_i N_i W_i}{N \sum_i W_i}$$

Where i runs over all macrostates. In quantum statistical mechanics the multiplicity in each macrostate is one i.e. $W_i = 1$

Particle is spin $\frac{1}{2}$

In our example there are only 3 macrostates. Which is shown below

Energy of the particles

Macrostate	0	1	2	3	4	5	6	Total energy
1	2	2	0	0	1	0	0	6
2	2	1	1	1	0	0	0	6
3	1	2	2	0	0	0	0	6

$$P(\epsilon) = \frac{\sum_{i=1}^3 N_i W_i}{N \sum_i W_i}$$

$$P(\epsilon) = \frac{N_1 W_1 + N_2 W_2 + N_3 W_3}{N (W_1 + W_2 + W_3)}$$

In quantum statistical mechanics

$$W_1 = W_2 = W_3 = 1$$

$$\therefore P(\epsilon) = \frac{N_1 + N_2 + N_3}{N \cdot 3}, \quad N_1 + N_2 + N_3 = N \text{ total number}$$

$$P(0) = \frac{2+2+1}{5 \cdot 3} = \frac{1}{3} = 0.333$$

$$P(1) = \frac{2+1+2}{5 \cdot 3} = \frac{1}{3} = 0.333$$

$$P(2) = \frac{0+1+2}{5 \cdot 3} = \frac{1}{5} = 0.2$$

$$P(3) = \frac{0+1+0}{5 \cdot 3} = \frac{1}{15} = 0.067$$

$$P(4) = \frac{1+0+0}{5 \cdot 3} = \frac{1}{15} = 0.067$$

$$P(5) = \frac{0+0+0}{5 \cdot 3} = \frac{0}{15} = 0.000$$

$$P(6) = \frac{0+0+0}{5 \cdot 3} = \frac{0}{15} = 0.000$$

Plotting a graph between energy on the x-axis and probability $P(\epsilon)$ on the Y-axis we get a graph shown in figure.

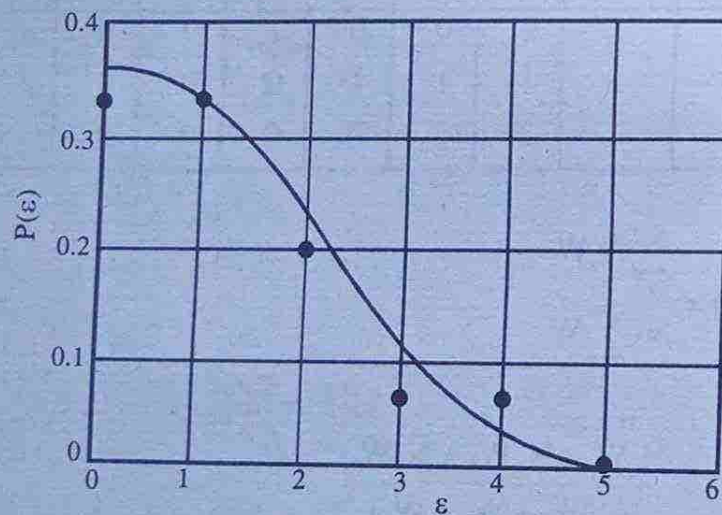

Figure 1.2: Probability versus energy graph for spin $\frac{1}{2}$ particles

The graph is not approximately exponential but flat near $\epsilon = 0$ then drops rapidly to 0 for the high energies.

A rigorous mathematical calculation shows that

$$P(\epsilon) = \frac{1}{Ae^{\beta\epsilon} + 1}$$

If we neglect 1 in the denominator, the quantum statistical probability becomes analogous to classical statistical probability.

Probability for integral spin particles (photon or α - particles)

In general integral spin particles are called Bosons. Bosons do not obey Pauli's exclusion principle. Each energy state of the system can accommodate in any number of particles. In our example of 6 units of energy and 5 particles now which are bosons have 10 macrostates with equal multiplicities of one.

$$\text{We have } P(\epsilon) = \frac{\sum_{i=1}^{10} N_i W_i}{N \sum_{i=1}^{10} N_i W_i}$$

$$P(\epsilon) = \frac{\sum_{i=1}^{10} N_i}{N \sum_{i=1}^{10} W_i} \quad \because W_i = 1, i = 1, 2, \dots, 10$$

From the table I (page 12)

$$P(0) = \frac{4+3+3+2+2+3+2+1+1+0}{5 \times 10}$$

$$P(0) = \frac{21}{50} = 0.420$$

$$P(1) = \frac{0+1+0+2+1+0+0+3+2+4}{5 \times 10}$$

$$P(1) = \frac{13}{50} = 0.260$$

$$P(2) = \frac{0+0+1+0+1+0+3+0+2+1}{5 \times 10}$$

$$P(2) = \frac{8}{50} = 0.160$$

$$P(3) = \frac{0+0+0+0+1+2+0+1+0+0}{5 \times 10}$$

$$P(3) = \frac{4}{50} = 0.080$$

$$P(4) = \frac{0+0+1+1+0+0+0+0+0+0}{5 \times 10}$$

$$P(4) = \frac{2}{50} = 0.040$$

$$P(5) = \frac{0+1+0+0+0+0+0+0+0+0}{5 \times 10}$$

$$P(5) = \frac{1}{50} = 0.020$$

$$P(6) = \frac{1+0+0+0+0+0+0+0+0+0}{5 \times 10}$$

$$P(6) = \frac{1}{50} = 0.020.$$

Plotting a graph between energy ϵ and the probability $P(\epsilon)$, we get a graph shown in figure below.

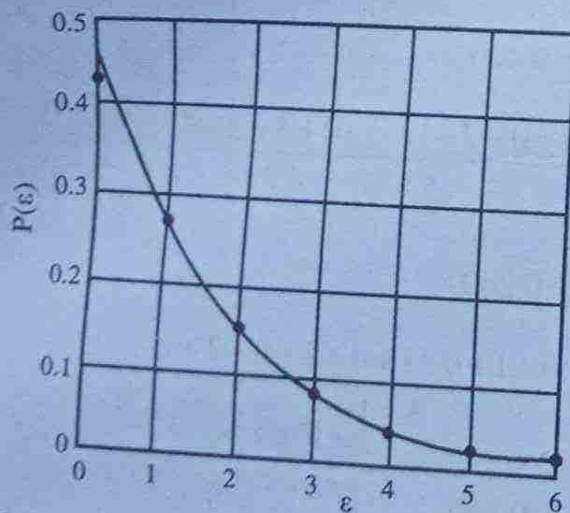

Figure 1.3: Probability versus energy for integral spin particles

From the plot it can be seen that the curve is approximately exponential but rises a bit more steeply at low energies. A rigorous mathematical calculation shows that probability is

$$P(\epsilon) = \frac{1}{Ae^{\beta\epsilon} - 1}$$

If we neglect one in the denominator the Boson probability is analogous to classical probability.

Note : It may be noted that the constant A appearing before the expressions of three probabilities are not the same. They are different constants.

Example 3

A system consists of 4 distinguishable simple harmonic oscillators each can have energy 0, ϵ , 2ϵ , 3ϵ , 4ϵetc. There is a constraint that the total energy is 4ϵ . Find the total number of microstates.

Solution

$$\text{We have } W_{\text{total}} = \frac{(N+Q-1)!}{Q!(N-1)!} = \frac{(4+4-1)!}{4!(4-1)!}$$

$$W_{\text{total}} = \frac{7!}{4!3!} = \frac{5 \times 6 \times 7}{1 \cdot 2 \cdot 3} = 35$$

OR

0	ϵ	2ϵ	3ϵ	4ϵ	$W = \frac{N!}{N_0!N_1!N_2!N_3!N_4!N_5!}$
3	0	0	0	1	$W_1 = 4$
2	1	0	1	0	$W_2 = 12$
2	0	2	0	0	$W_3 = 6$
1	2	1	0	0	$W_4 = 12$
0	4	0	0	0	$W_5 = 1$

$$\text{So } W_{\text{total}} = 4 + 12 + 6 + 12 + 1 = 35$$

Example 4

A gas has two particles a and b. How these particles can be arranged in 3 states 1, 2, 3 treating particles as a) classical b) having half integral c) having integral spin.

Solution

a) As classical particle

1	2	3
a	b	-
b	a	-
ab	-	-
0	ab	-
0	-	ab
a	0	b
0	a	b
0	b	a
b	0	a

Totally there are nine arrangements. i.e., total number of microstates = 9. Using a simple formula we can calculate W . If there are N_i number of particles and g_i number of states, $W = g_i^{N_i} = 3^2 = 9$

b) As half integral spin particles

Here $a = b \equiv a$

1	2	3
a	a	0
a	0	a
0	a	a

So there is only 3 microstates. For spin half particles, if there are N_i particles and g_i states then

$$W = \frac{g_i!}{N_i!(g_i - N_i)!} = \frac{3!}{2!(3-2)!} = 3$$

c) As integral spin particles

Here $a = b \equiv a$. Being Bosons any number of particles can be accommodated in each energy state

1	2	3
a	a	0
a	0	a
0	a	a
aa	0	0
0	aa	0
0	0	aa

∴ The number of microstates = 6

$$\text{Using the formula } W = \frac{(N_i + g_i - 1)!}{N_i!(g_i - 1)!}$$

We can directly calculate this

$$W = \frac{(2+3-2)!}{2!2!} = \frac{4!}{2!2!} = 6$$

Example 5

A system of four oscillator like particles shares 8 units of energy. Particle can accept energy only in equal units, in which oscillator spacing is one unit.

- List the macrostates and for each macrostate give the number of microstates for distinguishable classical particles, indistinguishable quantum particles with integral spin and with half integral spin.
- Calculate the probability to find a particle with exactly 2 units of energy for each of the three different types of particles.

Solution

We have four particles and 8 units of energy.

Treating particles as classical

Macrostate possible	Energy of particles									Total energy
	0	1	2	3	4	5	6	7	8	
1	3	0	0	0	0	0	0	0	1	8
2	2	1	0	0	0	0	0	1	0	8
3	1	2	0	0	0	0	1	0	0	8
4	0	3	0	0	0	1	0	0	0	8
5	2	0	0	1	0	1	0	0	0	8
6	2	0	1	0	0	0	1	0	0	8
7	0	1	2	1	0	0	0	0	0	8
8	1	1	1	0	0	1	0	0	0	8
9	1	1	0	1	1	0	0	0	0	8
10	0	2	1	0	1	0	0	0	0	8
11	1	0	2	0	1	0	0	0	0	8
12	2	0	0	0	2	0	0	0	0	8
13	1	0	1	2	0	0	0	0	0	8
14	0	2	0	2	0	0	0	0	0	8
15	0	0	4	0	0	0	0	0	0	8

There are no more possibilities. Thus we have totally 15 macrostates.
In each macrostate we have to calculate the multiplicity W .

$$\text{In general } W_i = \frac{N!}{N_0! N_1! N_2! N_3! N_4! N_5! N_6! N_7! N_8!}$$

We can calculate one by one.

$$W_1 = \frac{4!}{3! 1!} = 4, \quad (\because 0! = 1 \text{ and } 1! = 1)$$

$$W_2 = \frac{4!}{2!} = 12,$$

$$W_3 = \frac{4!}{1! 2! 1!} = 12,$$

$$W_4 = \frac{4!}{3! 1!} = 4,$$

$$W_5 = \frac{4!}{2!} = 12,$$

$$W_6 = \frac{4!}{2!} = 12,$$

$$W_7 = \frac{4!}{2!} = 12,$$

$$W_8 = 4! = 24$$

$$W_9 = \frac{4!}{2!} = 24,$$

$$W_{10} = \frac{4!}{2!} = 12,$$

$$W_{11} = \frac{4!}{2! 1!} = 12,$$

$$W_{12} = \frac{4!}{2!2!} = 6,$$

$$W_{13} = \frac{4!}{2!} = 12,$$

$$W_{14} = \frac{4!}{2!2!} = 6,$$

$$W_{15} = \frac{4!}{4!} = 1,$$

∴ Over all total multiplicity

$$W_{\text{total}} = 4 + 12 + 12 + 4 + 12 + 12 + 24 + 24 + 12 + 12 + 12 + 6 + 12 + 6 + 1$$

$$W_{\text{total}} = 165$$

There is another nice way to calculate W_{total} . If there are N particles sharing Q units of energy, then

$$W_{\text{total}} = \frac{(N+Q-1)!}{Q!(N-1)!} = \frac{(4+8-1)!}{8!(4-1)!} = \frac{11!}{8!3!}$$

$$W_{\text{total}} = 165$$

b) **Probability $P(\epsilon)$**

$$\text{We have } P(\epsilon) = \frac{\sum_i N_i W_i}{N \sum_i W_i}$$

i runs over all macrostates

$$P(\epsilon) = \frac{\sum_{i=1}^{15} N_i W_i}{N \sum_{i=1}^{15} W_i}$$

$$\therefore P(2) = \frac{0 \times 4 + 0 \times 12 + 0 \times 12 + 0 \times 4 + 0 \times 12 + 1 \times 12 + 2 \times 12 + 1 \times 24 + 0 \times 24 + 1 \times 12 + 2 \times 12 + 0 \times 6 + 1 \times 12 + 0 \times 6 + 4 \times 1}{4 \times 165}$$

$$P(2) = \frac{12 + 24 + 24 + 12 + 24 + 12 + 4}{4 \times 165} = \frac{112}{4 \times 165}$$

$$P(2) = 0.170$$

Treating particles as having half integral spin

Half integral particles obey Pauli's exclusion principle. Hence each energy state can accommodate only two particles at maximum. From the table we can see that macrostates 1, 4 and 15 are not allowed. Hence total number of macrostates possible is $(15 - 3) = 12$ since particle is quantum, multiplicity of each macrostate is 1. The total number of microstates is 12.

$$P(\epsilon) = \frac{\sum_{i=1}^{12} N_i W_i}{N \sum_{i=1}^{12} W_i} = \frac{\sum_{i=1}^{12} N_i}{4 \times 12} \quad W_i = 1$$

$$\therefore P(2) = \frac{N_1 + N_2 + N_3 + N_4 + N_5 + N_6 + N_7 + N_8 + N_9 + N_{10} + N_{11} + N_{12}}{48}$$

Collecting only the number of particles with energy 2 units.

$$N_1 = 0, N_2 = 0, N_3 = 0, N_4 = 1, N_5 = 0, N_6 = 1, N_7 = 0, N_8 = 1, N_9 = 2,$$

$$N_{10} = 0, N_{11} = 1 \text{ and } N_{12} = 2$$

$$P(2) = \frac{0 + 0 + 0 + 1 + 0 + 1 + 0 + 1 + 2 + 0 + 1 + 2}{48}$$

$$P(2) = \frac{8}{48} = 0.167$$

Treating particles as having integral spin

Integral spin particles can accommodate any number of particles in each energy state. Hence the number of macrostates is obviously 15. Since this being quantum particles, the multiplicity of each macrostate is one.

∴ The total number of microstate is 15. Collecting the number of particles from each macrostate having 2 units of energy we get

$$N_1 = 0, N_2 = 0, N_3 = 0, N_4 = 0, N_5 = 0, N_6 = 1, N_7 = 2, N_8 = 1, N_9 = 0, N_{10} = 1,$$

$$N_{11} = 2, N_{12} = 0, N_{13} = 1, N_{14} = 0, \text{ and } N_{15} = 4$$

$$P(\epsilon) = \frac{\sum_{i=1}^{15} N_i W_i}{N \sum_{i=1}^{15} W_i} \quad \begin{array}{l} W_i = 1 \\ \sum_{i=1}^{15} W_i = 15 \end{array}$$

$$P(\epsilon) = \frac{\sum_{i=1}^{15} N_i}{4 \times 15}$$

$$P(2) = \frac{0+0+0+0+0+1+2+1+0+1+2+0+1+0+4}{60}$$

$$P(2) = \frac{12}{60} = \frac{1}{5} = 0.20.$$

Example 6

A system containing 4 electrons and 5 α -particles. Calculate the total number of microstates.

Solution

Electron is a spin $\frac{1}{2}$ particle, each electron has $(2s+1)$ states $= 2 \times \frac{1}{2} + 1 = 2$ states.

∴ Number of microstates of 4 electrons $= 2^4 = 16$

α -particle is a spin 1 particle, each particle has $2 \times 1 + 1 = 3$ states

∴ Number of microstates of 5 α -particles $= 3^5 = 243$.

∴ Over all number of microstates $= 243 \times 16$
 $= 3888$

Density of states

We found that how the multiplicity of a state determines the probability to find a system in that state. There we considered only simple systems and containing only few number of particles. Now we are going to extend this concept to more complicated systems.

Let us consider a system (classical or quantum) composed of a large number of particles that can exist in many different ways. The relative probability for the particles to have energy ϵ is given by the distribution function $P(\epsilon) \propto e^{-\beta\epsilon} = f(\epsilon)$ where

β is found to be $\frac{1}{kT}$ (k is the Boltzmann's constant and T is the temperature in kelvin). The distribution function $f(\epsilon)$ tells us that when the energy of the particle ϵ is large, the particle is less likely to be found in the system. Since $f(\epsilon)$ depends upon the temperature of the system so also probability. If $\epsilon \gg kT$, the probability becomes more and more less probable.

Here our aim is to calculate the number of particles with any given value of energy ϵ . Thus number is partly given by $f(\epsilon)$. The other factor that has to be taken into account is the multiplicity of microstate. In effect to find the number of occupied states we combine the number of available states with the probability that each state is occupied.

Calculation of number of available states at energy ϵ

(i) When the energy states are discrete and individually observable.

In this case the number of available states at the energy ϵ is the degeneracy of the state (d) and the probability of the state is $f(\epsilon)$.

\therefore The number of particles (N_n) in the system with energy ϵ_n and probability $f(\epsilon_n)$ is given by

$$N_n = d_n f(\epsilon_n) \quad \dots (8)$$

\therefore The total number of particles in the system

$$N = \sum N_n = \sum_n d_n f(\epsilon_n) \quad \dots (9)$$

where the summation is carried over all the energy states.

Remember that for hydrogen gas the degeneracy is $2n^2$, for rotational excited

states in a molecule is $(2l + 1)$, where l is the orbital quantum number, and for electrons it is $(2s + 1)$ and so on.

(ii) **For energy states are continuous and cannot observe the individual states.**

This happens when the number of particles is exceedingly large. In this case the energy states are so closed so that we cannot observe them as separate. In this context we consider only the number of energy states in an interval between at energies ϵ and $\epsilon + d\epsilon$. For this analysis we treat ϵ as a continuous variable so that we will be able to replace summation by integration.

Density of states $g(\epsilon)$

It is defined as the number of available states per unit volume in the interval $d\epsilon$ energy ϵ . This is symbolically represented as $g(\epsilon)d\epsilon$.

The total number of states in the interval $d\epsilon$ is

$$dN = N(\epsilon)d\epsilon = Vg(\epsilon)f(\epsilon)d\epsilon \quad \dots (10)$$

$N(\epsilon)$ is not the total number of particles but it is the number of particles with energy ϵ .

The total number of particles in system can be obtained by integrating the above expression.

$$\therefore N = \int_0^{\infty} N(\epsilon)d\epsilon = V \int_0^{\infty} g(\epsilon)f(\epsilon)d\epsilon \quad \dots (11)$$

Here it is taken that energy (ϵ) of the particle varies from 0 to ∞ .

Density of states in a gas of particles

Here we calculate the density of states in a gas of particles such as electrons or molecules. This calculation is necessary in our further studies. For example suppose we study the thermionic emission by statistical analysis. The space around a hot filament is filled with a cloud of electrons. To study the properties of thermionic emission first of all we have to calculate the density of states for further development of the theory. Another example is suppose we want to study the properties of metals by statistical analysis. Metal consists of large number of free electrons which are responsible for all properties exhibited by metals. For the statistical analysis of the system first of all we have to calculate the density of states of the system.

Calculation of $g(\epsilon)$

The basis of our calculation is the particle (electron) trapped in a cubical box of side L . The energy of the particle is given by

$$\epsilon = \frac{p^2}{2m} = \frac{(p_x^2 + p_y^2 + p_z^2)}{2m} = \frac{h^2}{8mL^2} (n_x^2 + n_y^2 + n_z^2)$$

$$\epsilon = \frac{h^2 n^2}{8mL^2} \text{ where } n^2 = n_x^2 + n_y^2 + n_z^2$$

we can see that the number of energy states with a particular value of ϵ depends on how many combinations of n_x, n_y, n_z result in the same value of ϵ . Since we are dealing with almost a continuum of energy levels, we may construct a space of points represented by the values of n_x, n_y and n_z and let each point with integer values of the coordinates represent an energy state.

To find the number of energy states, construct a coordinate system with n_x, n_y and n_z as axes. The points with same value of ϵ lie on a spherical surface of radius $n = \sqrt{n_x^2 + n_y^2 + n_z^2}$. The points with energies between ϵ and $\epsilon + d\epsilon$ lie within a spherical shell between the radius n and $n + dn$.

The number of available states within a radius $n = \frac{1}{8} \left(\frac{4}{3} \pi n^3 \right)$

The factor $\frac{1}{8}$ accounts for the fact that only positive integer values of n_x, n_y and n_z are allowed and thus only one octant of the sphere alone be considered.

The number of states within a sphere

$$\text{of radius } n + dn = \frac{1}{8} \left(\frac{4}{3} \pi (n + dn)^3 \right)$$

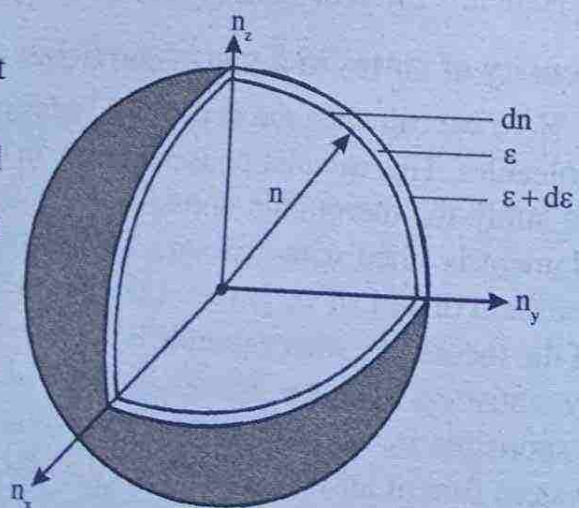

Figure 1.4: Density of states

∴ The number of energy states having energy values ϵ and $\epsilon + d\epsilon$,

$$\begin{aligned} &= \frac{1}{8} \frac{4}{3} \pi (n + dn)^3 - \frac{1}{8} \frac{4}{3} \pi n^3 \\ &= \frac{\pi}{6} [(n + dn)^3 - n^3] \\ &= \frac{\pi}{6} (3n^2 dn + 3ndn^2 + dn^3) \end{aligned}$$

Neglecting dn^2 and dn^3 , we get

$$\approx \frac{\pi}{2} n^2 dn$$

∴ The energy states per unit volume

$$g(n)dn = \frac{\text{Energy states}}{\text{Volume}} = \frac{\pi n^2 dn}{2V}$$

But each state is degenerate with degeneracy $(2s + 1)$ for fermions.

$$\therefore g(n)dn = (2s + 1) \frac{\pi n^2 dn}{2V}$$

If our particle is electron $s = \frac{1}{2}$

$$\therefore g(n)dn = \frac{\pi n^2 dn}{V} \text{ - for spin } \frac{1}{2} \text{ particles}$$

$$\text{We have } \epsilon = \frac{h^2 n^2}{8mL^2} \text{ gives } n^2 = \frac{8mL^2}{h^2} \epsilon$$

$$\text{or } n = \sqrt{8m} \frac{L}{h} \epsilon^{\frac{1}{2}}$$

$$dn = \sqrt{8m} \frac{L}{h} \epsilon^{-\frac{1}{2}} d\epsilon$$

$$= \sqrt{2m} \frac{L}{h} \epsilon^{-\frac{1}{2}} d\epsilon$$

Substituting the value of n^2 and n in the expression for $g(n)dn$, we get

$$g(n)dn = \frac{\pi}{V} \frac{8mL^2}{h^2} \varepsilon \sqrt{2m} \frac{L}{h} \varepsilon^{-\frac{1}{2}} d\varepsilon$$

The volume of the cube $V = L^3$, we started with

$$g(n)dn = \frac{8\sqrt{2}\pi m^{\frac{3}{2}}}{h^3} \varepsilon^{\frac{1}{2}} d\varepsilon$$

Now we change the symbolic representation of density of states $g(n)dn$ to $g(\varepsilon)d\varepsilon$, since energy states is expressed in terms of energy on the R.H.S.

$$\text{i.e.} \quad g(\varepsilon)d\varepsilon = \frac{8\sqrt{2}\pi m^{\frac{3}{2}}}{h^3} \varepsilon^{\frac{1}{2}} d\varepsilon$$

$$\text{In general} \quad g(\varepsilon) = \frac{4\sqrt{2}\pi(2s+1)m^{\frac{3}{2}}}{h^3} \varepsilon^{\frac{1}{2}} \quad \dots (12)$$

Note : For classical particles, the degeneracy is 1 and $h = h_0$

$$\therefore \quad g(\varepsilon)d\varepsilon = \frac{4\sqrt{2}\pi m^{\frac{3}{2}}}{h_0^3} \varepsilon^{\frac{1}{2}} d\varepsilon$$

Density of states in terms of momentum

$$\text{We have} \quad g(\varepsilon)d\varepsilon = \frac{4\sqrt{2}\pi(2s+1)m^{\frac{3}{2}}}{h^3} \varepsilon^{\frac{1}{2}} d\varepsilon$$

$$\text{Using} \quad \varepsilon = \frac{p^2}{2m} \quad d\varepsilon = \frac{p dp}{m}$$

$$\therefore \quad g(\varepsilon)d\varepsilon = \frac{4\sqrt{2}\pi(2s+1)m^{\frac{3}{2}}}{h^3} \frac{p}{(2m)^{\frac{1}{2}}} \frac{p dp}{m}$$

$$g(\varepsilon)d\varepsilon = \frac{4\pi(2s+1)p^2 dp}{h^3}$$

$$\text{i.e.} \quad g(p)dp = \frac{4\pi(2s+1)p^2 dp}{h^3}$$

..... (13)

This is called density of momentum states. This is the simplest formula, you can apply this anywhere.

$$\text{For classical particles } g(p)dp = \frac{4\pi p^2 dp}{h_0^3} \quad (\because 2s+1=1)$$

For classical particle

$$(i) \text{ Density of states in 3D, } g(p)dp = \frac{4\pi p^2 dp}{h_0^3}$$

$$(ii) \text{ Density of states in 2D, } g(p)dp = \frac{2\pi p dp}{h_0^2}$$

$$(iii) \text{ Density of states in 1D, } g(p)dp = \frac{dp}{h_0}$$

If the particle has degeneracy, multiply density of states with corresponding degeneracy and replace h_0 by Planck's constant h .

Density of states in a gas of photons

To find the density of photons we need not go for all the procedures that followed in the last section. We simply started with

$$g(p)dp = \frac{4\pi(2s+1)p^2 dp}{h^3}$$

For photons $s=1$, \therefore The degeneracy is found to be $=2 \times 1 + 1 = 3$. However photon has got only two since third state is not permitted. These are actually leading to two polarisations of electromagnetic waves.

$$\therefore g(p)dp = \frac{8\pi p^2 dp}{h^3}$$

$$\text{For a photon } p = \frac{\epsilon}{c} \quad \therefore dp = \frac{d\epsilon}{c}$$

$$g(p)dp = \frac{8\pi \epsilon^2 d\epsilon}{h^3 c^2 c}$$

$$g(\epsilon)d\epsilon = \frac{8\pi\epsilon^2 d\epsilon}{h^3 c^2}$$

i.e., the density of states of photon gas

$$g(\epsilon) = \frac{8\pi\epsilon^2}{h^3 c^2} \quad \dots (14)$$

Example 7

Calculate the density of states of helium gas within an interval of 0.0002 eV at the most probable molecular energy of 0.0086 eV at a temperature of 200K.

$$m_{\text{He}} = 3727 \text{ MeV}$$

Solution

$$d\epsilon = 0.0002 \text{ eV}, \quad \epsilon = 0.0086 \text{ eV}, \quad m_{\text{He}} = 3727 \text{ MeV}$$

$$\text{Density of states, } g(\epsilon)d\epsilon = \frac{4\pi\sqrt{2}m^{\frac{3}{2}}}{h^3} \epsilon^{\frac{1}{2}} d\epsilon \quad (\text{Treated as classical particle})$$

$$\text{The above equation can be re-written as } g(\epsilon)d\epsilon = \frac{4\pi\sqrt{2}(mc^2)^{\frac{3}{2}}}{(hc)^3} \epsilon^{\frac{1}{2}} d\epsilon$$

Putting the values $mc^2 = 3727 \times 10^6 \text{ eV}$, $\epsilon = 0.0086 \text{ eV}$ and $hc = 1240 \text{ eV}\cdot\text{nm}$

$$g(\epsilon)d\epsilon = \frac{4\pi\sqrt{2}(3727 \times 10^6 \text{ eV})^{\frac{3}{2}} \times (0.0086 \text{ eV})^{\frac{1}{2}} \times (0.0002 \text{ eV})}{(1240 \text{ nm eV})^3}$$

$$g(\epsilon)d\epsilon = \frac{4\pi\sqrt{2} \times 3727^{\frac{3}{2}} \times 10^9 \times 0.0086^{\frac{1}{2}} \times 0.0002}{1240^3 \text{ nm}^3}$$

$$g(\epsilon)d\epsilon = 39.3 \text{ nm}^{-3}$$

$g(\epsilon)d\epsilon$ is the number of states per unit volume (1m^3)

Converting into m^3

$$g(\epsilon)d\epsilon = \frac{39.3}{(10^{-9} \text{ m})^3} = 39.3 \times 10^{27} \text{ m}^{-3}$$

Example 8

A proton is confined to move in a nucleus with radius 10^{-14} m. Its momentum cannot exceed 10^{-19} kg ms⁻¹. Calculate the over all number of states.

Solution

$$p = 10^{-19} \text{ kg ms}^{-1}, \quad r = 10^{-14} \text{ m}$$

We have $g(p)dp = \frac{4\pi p^2 dp}{h^3}$ integrating we get, over all density of states per unit volume

$$\begin{aligned} &= \int_0^{p_{\max}} \frac{4\pi p^2 dp}{h^3} \\ &= \frac{4\pi p_{\max}^3}{3 h^3} \\ &= \frac{4 \times 3.14 \times (10^{-19})^3}{3 \times (6.64 \times 10^{-34})^3} \\ &= \frac{4 \times 3.14 \times 10^{45}}{3 \times 6.64^3} = 1.43 \times 10^{43} \end{aligned}$$

\therefore over all number of states $= 1.43 \times 10^{43} \times V$

$$\begin{aligned} &= 1.43 \times 10^{43} \times \frac{4}{3} \pi r^3 \\ &= 1.43 \times 10^{43} \times \frac{4}{3} \times 3.14 \times (10^{-14})^3 \\ &= 60 \end{aligned}$$

Example 9

The universe is filled with photons left over from the big bang that today have an energy of about 2×10^{-4} eV corresponding to a temperature of 2.7 K. Calculate the density of states of photons in an interval of 10^{-5} eV.

Solution

$$\varepsilon = 2 \times 10^{-4} \text{ eV}, \quad d\varepsilon = 10^{-5} \text{ eV}$$

$$\begin{aligned}
 \text{We have } g(\epsilon)d\epsilon &= \frac{8\pi\epsilon^2 d\epsilon}{h^3 c^3} \\
 &= \frac{8 \times 3.14 \times (2 \times 10^{-4} \text{ eV})^2 \times 10^{-5} \text{ eV}}{(1240 \text{ eV nm})^3} \\
 g(\epsilon)d\epsilon &= \frac{8 \times 3.14 \times 4 \times 10^{-8} \times 10^{-5}}{1240^3 \text{ nm}^3} \\
 g(\epsilon)d\epsilon &= \frac{8 \times 3.14 \times 4 \times 10^{-13}}{1240^3 \times (10^{-9} \text{ m})^3} \\
 &= \frac{8 \times 3.14 \times 4 \times 10^{14}}{1240^3 \text{ m}^3} \\
 &= 5.29 \times 10^6 \text{ m}^{-3}.
 \end{aligned}$$

Maxwell-Boltzmann distribution functions

To calculate the total number of particles in a system we require not only density of states but also distribution function $f(\epsilon)$. Depending upon the nature of the system of particles such as classical, fermions or bosons we have three types of corresponding distribution functions. For classical particles the distribution function is called Maxwell-Boltzmann distribution function denoted by $f(\epsilon)$. For fermions (half integral spin) the distribution function is called Fermi-Dirac distribution function denoted by $f_{\text{FD}}(\epsilon)$. For bosons (integral spin) the distribution function is called Bose-Einstein distribution function denoted by $f_{\text{BE}}(\epsilon)$. Distribution function tells us how the particles are distributed among different energy states of the system. Recall that our distribution functions are probability distribution functions.

Maxwell-Boltzmann distribution

Here our aim is to calculate the number of particles in a classical system in which the density is relatively low. This means that in such systems the average spacing between the particles is large compared with their de-Broglie wavelength. The individual particles may have quantised energy levels but the overall system does not show quantum behaviour. The Maxwell-Boltzmann distribution is given by

$$f_{\text{MB}}(\epsilon) = A^{-1} e^{-\frac{\epsilon}{kT}} \quad \dots (16)$$

The constant is taken as A^{-1} in order to have the same form for all the three distribution functions.

Now we will apply this to calculate the number of particles in a classical system.

Consider an ideal gas enclosed in a container of volume V . Let N be the number of molecules in the container at temperature T . Let $N(\epsilon)$ be the number of molecules in between energy ϵ and $\epsilon + d\epsilon$. We know that (Recall equation 10)

$$N(\epsilon)d\epsilon = V g(\epsilon) f_{MB}(\epsilon) d\epsilon \quad \dots (17)$$

Substituting for $g(\epsilon)$ from equation 12 and $f_{MB}(\epsilon)$ from equation 16, we get

$$N(\epsilon)d\epsilon = \frac{V 4\sqrt{2}\pi m^{\frac{3}{2}} \epsilon^{\frac{1}{2}} (2s+1) A^{-1} e^{-\frac{\epsilon}{kT}}}{h^3} \quad \dots (18)$$

Evaluation of the constant A^{-1}

$N(\epsilon)d\epsilon$ gives the number of particles in between energy ϵ and $\epsilon + d\epsilon$

\therefore The number of particles

$$N = \int_0^{\infty} N(\epsilon) d\epsilon$$

Since this being a classical system the variation of energy can be taken to be 0 to ∞ ,

$$N = \frac{V 4\sqrt{2}\pi m^{\frac{3}{2}} (2s+1) A^{-1}}{h^3} \int_0^{\infty} \epsilon^{\frac{1}{2}} e^{-\frac{\epsilon}{kT}} d\epsilon$$

Using the standard integral

$$\int_0^{\infty} x^n e^{-ax} dx = n!(a)^{-n-1}$$

$$\begin{aligned} \therefore \int_0^{\infty} \epsilon^{\frac{1}{2}} e^{-\frac{\epsilon}{kT}} d\epsilon &= \left(\frac{1}{2}\right)! \left(\frac{1}{kT}\right)^{-\frac{1}{2}-1} && \left(\frac{1}{2}\right)! = \frac{\sqrt{\pi}}{2} \\ &= \frac{\sqrt{\pi}}{2} (kT)^{\frac{3}{2}} \end{aligned}$$

$$N = \frac{V 2\sqrt{2}\pi^2 m^{\frac{3}{2}} (2s+1)(kT)^{\frac{3}{2}} A^{-1}}{h^3}$$

$$N = \frac{V}{h^3} (2s+1) (2\pi m kT)^{\frac{3}{2}} A^{-1}$$

or
$$A^{-1} = \frac{N h^3}{V(2s+1) (2\pi m kT)^{\frac{3}{2}}} \dots (19(a))$$

Substituting this in equation 18 we get

$$N(\epsilon)d\epsilon = \frac{V 4\sqrt{2}\pi m^{\frac{3}{2}} \epsilon^{\frac{1}{2}} (2s+1) e^{-\frac{\epsilon}{kT}}}{h^3} \times \frac{N h^3 d\epsilon}{V(2s+1) (2\pi m kT)^{\frac{3}{2}}}$$

$$N(\epsilon)d\epsilon = \frac{2N}{\sqrt{\pi} (kT)^{\frac{3}{2}}} \epsilon^{\frac{1}{2}} e^{-\frac{\epsilon}{kT}} d\epsilon \dots (19)$$

This is called Maxwell-Boltzmann energy distribution law.

The distribution of number of particles $N(\epsilon)$ with energy ϵ is shown in figure below.

It can be seen from the graph that $N(\epsilon)$ increases with energy. It rises to a maximum value, the corresponding energy is called most probable energy (ϵ_p). It is found to be $\frac{1}{2}kT$ (see example 9). After reaching maximum, $N(\epsilon)$ decreases to zero as energy increases. This shows that it is rare to find a molecule with energy much greater than kT . The number of molecules dN within the energy can be calculated by the equation 19. Moreover the average energy of the gas molecules can be calculated, it is found to be $\epsilon_m = \frac{3}{2}kT$ (see example 10). This is found to be in exact agreement with experimental result. This gives us a justification for the development of statistical analysis.

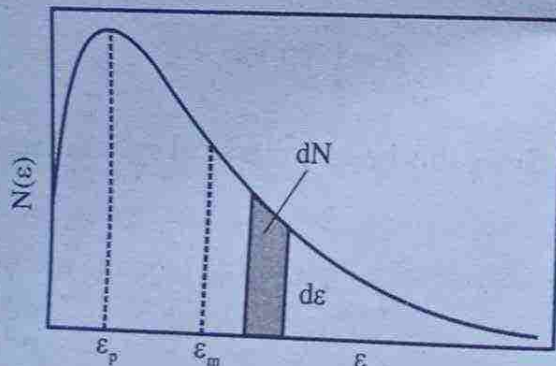

Figure 1.5
The Maxwell-Boltzmann energy distribution for molecules, showing the most probable energy ϵ_p and the mean energy ϵ_m . The shaded strip represents the number of molecules dN with energies between ϵ and $\epsilon + d\epsilon$

Note: The expression we derived for probability $p(\epsilon)$ enables us to calculate the relative population of particles in various energy states. Using $p(\epsilon) \propto d e^{-\frac{\epsilon}{kT}}$, where d is the degeneracy of each energy level. (see example 11 and 12).

Example 9

Show that the most probable energy $\epsilon_p = \frac{1}{2} kT$ in the case of Maxwell-Boltzmann distribution.

Solution

We have
$$N(\epsilon) = \frac{2N}{\sqrt{\pi}(kT)^{\frac{3}{2}}} \epsilon^{\frac{1}{2}} e^{-\frac{\epsilon}{kT}}$$

To find the maximum of $N(\epsilon)$, differentiate the above with respect to ϵ and put equal to zero.

$$\frac{dN(\epsilon)}{d\epsilon} = \frac{2N}{\sqrt{\pi}(kT)^{\frac{3}{2}}} \left[\epsilon^{\frac{1}{2}} e^{-\frac{\epsilon}{kT}} - \frac{1}{kT} + \frac{1}{2} \epsilon^{-\frac{1}{2}} e^{-\frac{\epsilon}{kT}} \right]$$

$$\frac{dN(\epsilon)}{d\epsilon} = 0 \text{ gives } \epsilon = \epsilon_p$$

$$0 = -\frac{\epsilon_p^{\frac{1}{2}} e^{-\frac{\epsilon_p}{kT}}}{kT} + \frac{1}{2} \epsilon_p^{-\frac{1}{2}} e^{-\frac{\epsilon_p}{kT}}$$

or
$$\frac{\epsilon_p^{\frac{1}{2}}}{kT} = \frac{1}{2} \epsilon_p^{-\frac{1}{2}}$$

$$\epsilon_p = \frac{1}{2} kT$$

Example 10

Show that the average energy of gas molecules obeying Maxwell-Boltzmann distribution is $\epsilon_m = \frac{3}{2} kT$

Solution

Total energy of the whole gas molecules

$$E = \int_0^{\infty} N(\epsilon) \epsilon d\epsilon$$

substituting for $N(\epsilon)$, we get

$$E = \int_0^{\infty} \frac{2N}{\sqrt{\pi}(kT)^{\frac{3}{2}}} \epsilon^{\frac{3}{2}} e^{-\frac{\epsilon}{kT}} d\epsilon$$

Using the standard integral $\int_0^{\infty} x^n e^{-ax} dx = n!(a)^{-n-1}$

$$\int_0^{\infty} \epsilon^{\frac{3}{2}} e^{-\frac{\epsilon}{kT}} d\epsilon = \left(\frac{3}{2}\right)! \left(\frac{1}{kT}\right)^{-\frac{3}{2}-1}$$

$$= \frac{3}{2} \frac{1}{2} \sqrt{\pi} (kT)^{\frac{5}{2}} \quad \left(\frac{3}{2}! = \frac{3}{2} \frac{1}{2} \sqrt{\pi}\right)$$

$$\therefore E = \frac{2N}{\sqrt{\pi}(kT)^{\frac{3}{2}}} \frac{3}{2} \frac{1}{2} \sqrt{\pi} (kT)^{\frac{5}{2}}$$

$$E = \frac{3}{2} NkT$$

or $\frac{E}{N} = \frac{3}{2} kT$

$$\epsilon_m = \frac{3}{2} kT$$

Example 11

Nitrogen gas consists of a sequence of vibrating excited states with energies $(n + \frac{1}{2})\hbar\omega$, $n = 0, 1, 2, \dots$. If the level spacing is 0.3eV . What is the relative population of first excited state ($n = 1$) and the ground state ($n = 0$). $T = 1000\text{K}$, $k = 8.625 \times 10^{-5} \text{eVK}^{-1}$. Degeneracy = 1

Solution

We have $p(\epsilon) \propto e^{-\beta\epsilon}$

For the first excited state $n = 1$

$$\therefore \quad \varepsilon = \left(n + \frac{1}{2} \right) \hbar\omega$$

$$\varepsilon_1 = \frac{3}{2} \hbar\omega$$

For the ground state $n = 0$

$$\varepsilon_0 = \frac{1}{2} \hbar\omega$$

$$\therefore \quad p(\varepsilon_1) \propto e^{-\beta\varepsilon_1}$$

$$p(\varepsilon_0) \propto e^{-\beta\varepsilon_0}$$

$$\frac{p(\varepsilon_1)}{p(\varepsilon_0)} = \frac{e^{-\beta\varepsilon_1}}{e^{-\beta\varepsilon_0}} = e^{-\beta(\varepsilon_1 - \varepsilon_0)}$$

$$= e^{-\frac{(\varepsilon_1 - \varepsilon_0)}{kT}}$$

$$\varepsilon_1 - \varepsilon_0 = 0.3\text{eV}$$

$$k = 8.625 \times 10^{-5} \text{eV K}^{-1}$$

$$T = 1000 \text{K}$$

$$\frac{p(\varepsilon_1)}{p(\varepsilon_0)} = e^{-\frac{0.3\text{eV}}{8.625 \times 10^{-5} \text{eV K}^{-1} \times 1000 \text{K}}}$$

$$\frac{p(\varepsilon_1)}{p(\varepsilon_0)} = e^{-\frac{0.3 \times 10^2}{8.625}} = e^{-3.478} = 0.031$$

Example 12

In a gas of atomic hydrogen at room temperature 293 K what is the number of atoms in the first excited state at $\varepsilon = 10.2\text{eV}$, expressed as a ratio to the number in the ground state. b) At what temperature would we expect to find $\frac{1}{10}$ as many atoms in the first excited state as in the ground state.

Solution

We have $N \propto d e^{-\beta \epsilon}$

$$N_1 \propto d_1 e^{-\beta \epsilon_1}$$

$$N_2 \propto d_2 e^{-\beta \epsilon_2}$$

$$\therefore \frac{N_2}{N_1} = \frac{d_2}{d_1} e^{-\beta(\epsilon_2 - \epsilon_1)}$$

The degeneracy of hydrogen atom is $2n^2$

$$d_1 = 2 \times 1^2 = 2$$

$$d_2 = 2 \times 2^2 = 8$$

$$\epsilon_2 - \epsilon_1 = 10.2 \text{ eV}$$

$$k = 8.625 \times 10^{-5} \text{ eV K}^{-1}$$

$$T = 293 \text{ K}$$

$$\therefore \frac{N_2}{N_1} = \frac{8}{2} e^{-\frac{10.2 \text{ eV}}{8.625 \times 10^{-5} \text{ eV K}^{-1} \times 293 \text{ K}}}$$

$$\frac{N_2}{N_1} = 4e^{-404}, \text{ Let } e^{-404} = 10^x \text{ gives } x = -175.45$$

$$\frac{N_2}{N_1} = 4 \times 10^{-175.42}$$

$$\frac{N_2}{N_1} = 4 \times 10^{-175} \cdot 10^{-0.45} = 1.419 \times 10^{-175}$$

b) $\frac{N_2}{N_1} = \frac{1}{10} = 0.1$ given. $T = ?$

Using $\frac{N_2}{N_1} = 4e^{-\frac{\epsilon_2 - \epsilon_1}{kT}}$

$$\frac{1}{10} = 4e^{-\frac{10.2}{kT}}$$

$$\frac{1}{40} = e^{-\frac{10.2}{kT}}$$

or $e^{\frac{10.2}{kT}} = 40$

$$\frac{10.2}{kT} = \ln 40$$

$$kT = \frac{10.2}{\ln 40} = \frac{10.2}{3.69} = 2.76 \text{ eV}$$

$$\therefore T = \frac{2.76}{k} = \frac{2.76}{8.625 \times 10^{-5}} = \frac{2.76}{8.625} \times 10^4$$

$$T = 3.2 \times 10^4 \text{ K}$$

Distribution of molecular speeds

The number of molecules with energy in between ϵ and $\epsilon + d\epsilon$ is given by

$$N(\epsilon)d\epsilon = \frac{2N}{\sqrt{\pi}(kT)^{\frac{3}{2}}} \epsilon^{\frac{1}{2}} e^{-\frac{\epsilon}{kT}} d\epsilon$$

Using $\epsilon = \frac{1}{2}mv^2$, $d\epsilon = mv dv$ in the above equation, we get

$$N(\epsilon)d\epsilon = \frac{2N}{\sqrt{\pi}(kT)^{\frac{3}{2}}} \left(\frac{1}{2}mv^2\right)^{\frac{1}{2}} e^{-\frac{mv^2}{2kT}}, mv dv$$

Now the number particles with energy ϵ is written as a function of v , we have

$$N(v)dv = N \sqrt{\frac{2}{\pi}} \left(\frac{m}{kT}\right)^{\frac{3}{2}} v^2 e^{-\frac{mv^2}{2kT}} dv \quad \dots (20)$$

This gives the number of particles with speeds in the interval dv at v .

This equation (20) is called Maxwell-Boltzmann speed distributio law.

Discussion**Case (i)**

$$\text{If } v = 0$$

$$N(v) = 0$$

It means that no molecule has zero speed

Case (ii)

For small value of v

$$\frac{mv^2}{2kT} \ll 1 \text{ and } e^{-\frac{mv^2}{2kT}} \approx 1$$

$$\therefore N(v) \propto v^2$$

Thus, value $N(v)$ increases parabolically with increase of v and attains a maximum value for a particular v called most probable speed.

Case (iii)

For large value of v

$\frac{mv^2}{2kT} \gg 1$ and the exponential term $\left(e^{-\frac{mv^2}{2kT}} \right)$ dominates over v^2 . Hence

$$N(v) \propto e^{-\frac{mv^2}{2kT}}$$

Thus $N(v)$ decreases exponentially with increase of v .

When we plot a graph between $n(v)$ and v , the curve starts from the origin ($v=0, N(v)=0$) then rises parabolically ($N(v) \propto v^2$) and then falls exponentially.

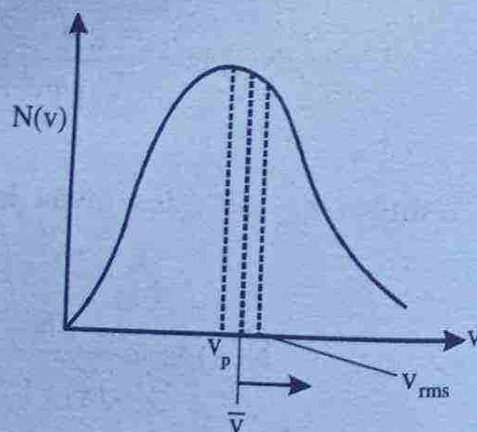

Figure 1.6

RMS speed, most probable speed and mean speed**RMS speed**

The mean square speed (\bar{v}^2) is given by

$$\bar{v}^2 = \frac{1}{N} \int_0^{\infty} v^2 N(v) dv$$

$$\bar{v}^2 = \frac{1}{N} \int_0^{\infty} 4\pi N \left(\frac{m}{2\pi kT} \right)^{\frac{3}{2}} v^4 e^{-\frac{mv^2}{2kT}} dv$$

$$\bar{v}^2 = 4\pi \left(\frac{m}{2\pi kT} \right)^{\frac{3}{2}} \int_0^{\infty} v^4 e^{-\frac{mv^2}{2kT}} dv \quad \dots (21)$$

Evaluation of $\int_0^{\infty} v^4 e^{-\frac{mv^2}{2kT}} dv$

Put $v^2 = x$ then $2v dv = dx$

or $dv = \frac{dx}{2v} = \frac{dx}{2\sqrt{x}}$

$$\therefore \int_0^{\infty} v^4 e^{-\frac{mv^2}{2kT}} dv = \int_0^{\infty} x^2 e^{-\frac{mx}{2kT}} \frac{dx}{2\sqrt{x}}$$

$$= \frac{1}{2} \int_0^{\infty} x^{\frac{3}{2}} e^{-\frac{mx}{2kT}} dx$$

$$= \frac{1}{2} \left(\frac{3}{2} \right)! \left(\frac{m}{2kT} \right)^{\frac{3}{2}-1}$$

$$= \frac{1}{2} \cdot \frac{3}{2} \cdot \frac{1}{2} \cdot \sqrt{\pi} \cdot \left(\frac{2kT}{m} \right)^{\frac{5}{2}}$$

$$= \frac{3}{8} \sqrt{\pi} \cdot \left(\frac{2kT}{m} \right)^{\frac{5}{2}}$$

Putting this in eqn (21), we get

$$\bar{v}^2 = 4\pi \left(\frac{m}{2\pi kT} \right)^{\frac{3}{2}} \frac{3}{8} \sqrt{\pi} \left(\frac{2kT}{m} \right)^{\frac{5}{2}}$$

$$\bar{v}^2 = \frac{3kT}{m}$$

Taking square root on both sides, we get the rms speed

$$\text{i.e., } v_{\text{rms}} = \sqrt{\bar{v}^2} = \sqrt{\frac{3kT}{m}} \quad \dots (22)$$

Most probable speed (v_p)

Most probable speed is defined as the speed at which the number of molecules is maximum.

i.e., To find the most probable speed, find $\frac{dN(v)}{dv}$, then

$$\text{Put } \frac{dN(v)}{dv} = 0. \text{ Then } v = v_p$$

We have

$$N(v) = 4\pi N \left(\frac{m}{2\pi kT} \right)^{\frac{3}{2}} v^2 e^{-\frac{mv^2}{2kT}}$$

$$\frac{dN(v)}{dv} = 4\pi N \left(\frac{m}{2\pi kT} \right)^{\frac{3}{2}} \left[v^2 e^{-\frac{mv^2}{2kT}} \times -\frac{m}{kT} 2v + e^{-\frac{mv^2}{2kT}} 2v \right]$$

$$\text{When } \frac{dN(v)}{dv} = 0, v = v_p$$

$$0 = -v_p^2 e^{-\frac{mv_p^2}{2kT}} \frac{mv_p}{kT} + e^{-\frac{mv_p^2}{2kT}} 2v_p$$

$$\text{or } 0 = -\frac{mv_p^3}{kT} + 2v_p$$

$$\text{or } v_p = \sqrt{\frac{2kT}{m}} \quad \dots (23)$$

Mean or average speed (\bar{v})

If there are n_i molecules each having speed v_i , then the mean or average speed (\bar{v}) is defined as

$$\bar{v} = \frac{1}{N} \int_0^{\infty} N(v) v dv$$

$$\bar{v} = \frac{1}{N} \int_0^{\infty} 4\pi N \left(\frac{m}{2\pi kT} \right)^{\frac{3}{2}} v^3 e^{-\frac{mv^2}{2kT}} dv$$

$$\bar{v} = 4\pi \left(\frac{m}{2\pi kT} \right)^{\frac{3}{2}} \int_0^{\infty} v^3 e^{-\frac{mv^2}{2kT}} dv \quad \dots (24)$$

Evaluation of the Integral $\int_0^{\infty} v^3 e^{-\frac{mv^2}{2kT}} dv$

put $v^2 = x \therefore 2v dv = dx$

or $dv = \frac{dx}{2v} = \frac{dx}{2\sqrt{x}}$

$$\int_0^{\infty} v^3 e^{-\frac{mv^2}{2kT}} dv = \int_0^{\infty} x^{\frac{3}{2}} e^{-\frac{mx}{2kT}} \frac{dx}{2\sqrt{x}}$$

$$= \frac{1}{2} \int_0^{\infty} x e^{-\frac{mx}{2kT}} dx$$

Using the standard integral

$$= \frac{1}{2} (1)! \left(\frac{m}{2kT} \right)^{-1-1} = \frac{1}{2} \left(\frac{2kT}{m} \right)^2$$

Putting this in eqn 24, we get

$$\bar{v} = 4\pi \left(\frac{m}{2\pi kT} \right)^{\frac{3}{2}} \cdot \frac{1}{2} \left(\frac{2kT}{m} \right)^2 = \sqrt{\frac{8kT}{\pi m}}$$

$$\bar{v} = \sqrt{\frac{8kT}{\pi m}} \quad \dots (25)$$

From eqn 22, 23 and 25 we can see that

$$v_{\text{rms}} > \bar{v} > v_p$$

(see the figure 1.6)

All equations derived so far (for v_{rms} , v_p and \bar{v}) from statistical considerations are found to be in well agreement with the thermodynamical experimentally verified equations. This is actually the strength of statistical mechanics and its postulates.

Maxwell speed distribution law is more important than Maxwell-Boltzmann energy distribution law. Because all the parameters (v_{rms} , v_p , v_{mean}) predicted can be measured experimentally.

Experimental determination of molecular speeds

The experimental arrangement consists of an oven enclosed in a box provided with hole on one side through which a stream of molecules are escaping. The hole is made small enough so that the distribution of speeds inside the oven is not changed. The beam of molecules is allowed to pass through a slot in a disc attached to an axle rotating at an angular speed ω . At the other end of the axle there is another slotted disc. The slot on the second disc is displaced from the first by an angle θ . In order for a molecule to pass through both slots and strike the detector, it must travel through the length L of the axle in the same time that it takes the axle to rotate by the angle θ .

$$\text{Thus } t = \frac{L}{v} = \frac{\theta}{\omega} \quad \left(\because v = \frac{x}{t} \text{ and } \omega = \frac{\theta}{t} \right)$$

Keeping L and θ fixed, we can vary ω , measuring the number of molecules striking the detector for each different value of ω enables us to measure the Maxwell speed distribution. For a particular ω measure the intensity from the detector.

Increase ω gradually step by step each time measure the intensity from the detector. Plot a graph between $v \left(v = \frac{L\omega}{\theta} \right)$ along the horizontal axis and intensity along the vertical axis we get a graph perfectly in agreement with Maxwell's speed distribution law. See the experimental arrangement and the graphical result shown below.

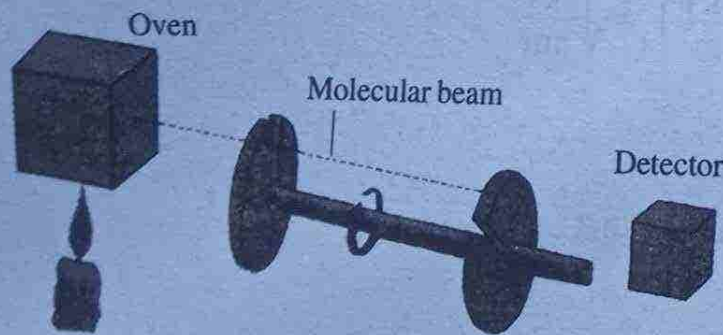

Figure 1.7

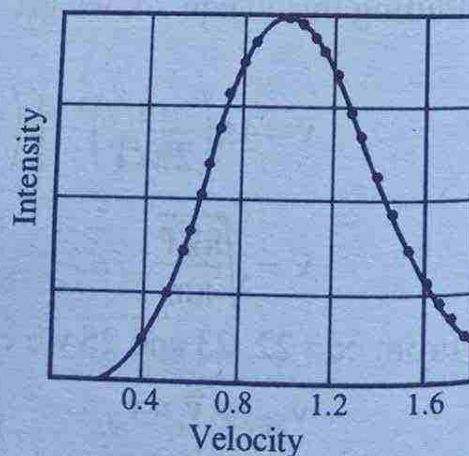

Figure 1.8

Result of measurement of the distribution of atomic speeds in thallium-vapour. The solid line is obtained from the Maxwell speed distribution for an oven temperature of 870 K.

In the experiment what we measure is $N(v)dv$. The range of velocities is dv , determined by the width of the slot. To collect the number of particles with velocity v , we have to make dv , so small. i.e., the slit width is so small. If you make the slit width zero, $dv = 0$ thus $N(v) = 0$.

Quantum statistics

Maxwell-Boltzmann statistics can be applied to classical particles which explained the energy and velocity distribution of the molecules of an ideal gas to a fairly large degree of accuracy. The classical particles are identical and distinguishable. They are distinguishable since the average spacing between the particles is large compared with their de-Broglie wavelength. Moreover while deriving Maxwell-Boltzmann distribution law it has been assumed that all the energy levels are accessible to all the particles of the system. However there are particles which are indistinguishable. They are indistinguishable since the average spacing between the particles is small compared with their de-Broglie wavelengths. (i.e. particles wave functions overlap). Among the several indistinguishable types of particles some of them obey Pauli's exclusion principle and some of them do not. The fermions (half integral spin) are indistinguishable particles which obey Pauli's exclusion principle and certain energy levels are forbidden to these particles. The bosons (integral spin) are also indistinguishable particles which do not obey Pauli's exclusion principle and can accommodate any number of particles in any state. MB statistics failed to explain the phenomena exhibited by these particles. To explain these quantum statistics was developed. The quantum statistics can be classified into two. They are

- (i) Bose-Einstein (BE) statistics
- (ii) Fermi-Dirac statistics.

Bose-Einstein statistics

This statistics was developed by Indian scientist S.N. Bose and later on developed by Albert Einstein. The only difference between the MB statistics and BE statistics is in their distribution functions. It is due to the indistinguishable nature of bosons its distribution function is different from that of classical (MB). The Bose-Einstein distribution function is given by

$$f_{BE}(\epsilon) = \frac{1}{A_{BE} e^{\beta\epsilon} - 1} \quad \dots (26)$$

The constant A_{BE} can be evaluated by normalising $f_{BE}(\epsilon)$. The normalisation depends on the total number of bosons. In the case of photons, where the number is

not conserved, $A_{BE} = 1$. In most of the cases the constant A_{BE} is independent of temperature T or depends so weakly on T .

Fermi-Dirac statistics

This statistics was developed by Enrico Fermi and P.A.M. Dirac hence called Fermi-Dirac statistics shortly called FD statistics. This applies to identical, indistinguishable particles which obey Pauli's exclusion principle (half integral spin particles). This half integral particles are called fermions which are indistinguishable because their wave functions overlap. The only difference between MB statistics and FD statistics is in their distribution function. It is due to the indistinguishable nature and the Pauli's exclusion principle that it obeys FD distribution function is different from that of classical (MB).

The Fermi-Dirac distribution function is given by

$$f_{BE}(\epsilon) = \frac{1}{A_{FD} e^{\frac{\epsilon}{kT}} + 1} \quad \dots (27)$$

The term A_{FD} can be evaluated by the theoretical consideration of properties of fermions. It is found that A_{FD} depends strongly on temperature T and evaluated to be

$$A_{FD} = e^{-\frac{\epsilon_F}{kT}}$$

where ϵ_F is called the Fermi energy.

Thus

$$f_{FD}(\epsilon) = \frac{1}{e^{\frac{\epsilon - \epsilon_F}{kT}} - 1} \quad \dots (28)$$

Equation 28 is called Fermi-Dirac distribution function.

Difference between BE and FD distribution functions

(i) In the BE distribution we have

$$f_{BE}(\epsilon) = \frac{1}{e^{\frac{\epsilon}{kT}} - 1} \quad \text{where } A_{BE} = 1 \text{ (assumed)}$$

when the temperature is very small ($T \rightarrow 0$) the exponential factor becomes large for larger energy ϵ .

So $f_{BE}(\epsilon) \rightarrow 0$ for $T \rightarrow 0$ and ϵ large. This means that the probability of occupying higher state at very small temperature ($T \rightarrow 0$) is zero.

When $\epsilon \rightarrow 0$, T is also small, then

$$f_{BE}(\epsilon) = \frac{1}{e^{\frac{0}{kT}} - 1} = \frac{1}{1-1} = \frac{1}{0} = \infty.$$

This shows that the probability of occupying ground state ($\epsilon \rightarrow 0$) at very small temperature ($T \rightarrow 0$) is very high ($f_{BE}(\epsilon) \rightarrow \infty$). This effect is known as Bose-Einstein condensation.

In the case of fermions, we have

$$f_{FD}(\epsilon) = \frac{1}{e^{\frac{\epsilon - \epsilon_F}{kT}} + 1}$$

For $\epsilon > \epsilon_F$ and $T \rightarrow 0$, then $\epsilon - \epsilon_F$ is +ve

$$\therefore f_{FD}(\epsilon) = \frac{1}{e^{\frac{+ve}{0}} + 1} = \frac{1}{\infty + 1} = \frac{1}{\infty} = 0.$$

This shows that the probability of occupying energy state $\epsilon > \epsilon_F$ by the particle is zero at $T \rightarrow 0$. In other words at $T \rightarrow 0$ all particles occupy the energy states $\epsilon < \epsilon_F$.

For $\epsilon < \epsilon_F$ and $T \rightarrow 0$, then $\epsilon - \epsilon_F$ is -ve

$$\therefore f_{FD}(\epsilon) = \frac{1}{e^{\frac{-ve}{0}} + 1} = \frac{1}{e^{-\infty} + 1} = \frac{1}{0+1} = 1$$

This shows that the probability of occupying state with energy $\epsilon < \epsilon_F$ at very small temperature ($T \rightarrow 0$) is one. The three distribution functions f_{MB} , f_{BE} and f_{FD} are plotted against energy ϵ are shown below.

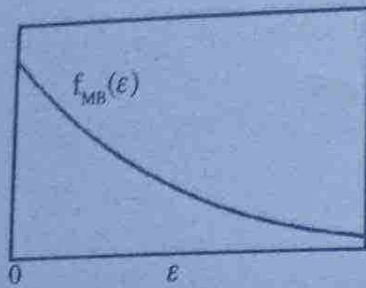

Figure 1.9: The Maxwell-Boltzmann distribution function

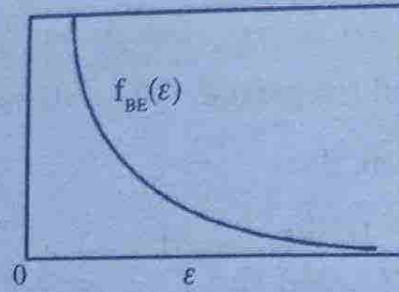

Figure 1.10: The Bose-Einstein distribution function

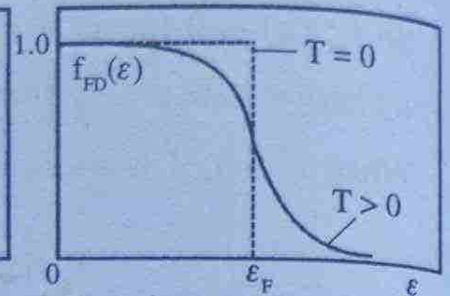

Figure 1.11: The Fermi-Dirac distribution function

The following also may be noted from the graphs.

(i) All of the distribution functions fall to zero at large values of ϵ . For $\epsilon \gg kT$ the occupation probability is very small.

(ii) When ϵ is very small ($\epsilon \rightarrow 0$)

$f_{MB}(\epsilon)$ is finite

$f_{BE}(\epsilon)$ is infinite

$f_{FD}(\epsilon)$ is one. It can never be greater than one.

(iii) The normalisation constants changes with changing the number of particles of the different distributions. Because normalisation constant depends on the number of particles on the system. The number of particles is determined by integrating the distribution function $f(\epsilon)$ after multiplying it by the density of states $g(\epsilon)d\epsilon$ and volume. In the case of MB distribution when the number of particles increases the intercept rises, thus raising the entire curve. This is as follows

We have
$$f_{MB}(\epsilon) = A^{-1} e^{-\frac{\epsilon}{kT}}$$

To find the intercept put $\epsilon = 0$, then $f_{MB}(\epsilon) = A^{-1}$

But $A^{-1} \propto N$ see equation (19(a)).

In the case of FD distribution, we have

$$f_{FD}(\epsilon) = \frac{1}{e^{\frac{\epsilon - \epsilon_F}{kT}} + 1}$$

For $\varepsilon < \varepsilon_F$, the intercept is 1 at $T = 0$ when the number of particles N increases ε_F increases to accommodate large number of particles as a result the intercept is kept constant at value one.

Fermi energy (ε_F)

To introduce the concept of Fermi energy consider a gas of electrons described by the density function $g(\varepsilon)$ (see equation (12)) and $N(\varepsilon)$ is given as

$$N(\varepsilon)d\varepsilon = Vg(\varepsilon)f(\varepsilon)d\varepsilon$$

$$N(\varepsilon)d\varepsilon = V \frac{4\pi\sqrt{2}(2s+1)m^{\frac{3}{2}}\varepsilon^{\frac{1}{2}}d\varepsilon}{e^{\frac{\varepsilon-\varepsilon_F}{kT}} + 1} \quad \dots (29)$$

This equation shows that at $T = 0$, when ε increases $N(\varepsilon)$ increases up to $\varepsilon = \varepsilon_F$ according to $N(\varepsilon) \propto \varepsilon^{1/2}$

When a graph is drawn between $N(\varepsilon)$ and ε , we get almost a parabolic curve governed by $N(\varepsilon) \propto \varepsilon^{1/2}$ up to $\varepsilon = \varepsilon_F$.

The probability of filling the energy state is governed by

$$f(\varepsilon) = \frac{1}{e^{\frac{\varepsilon-\varepsilon_F}{kT}} + 1}$$

$$f(\varepsilon) = 1 \quad \text{for } \varepsilon < \varepsilon_F \text{ at } T = 0K$$

This shows that up to $\varepsilon = \varepsilon_F$, all energy levels are filled.

When $\varepsilon > \varepsilon_F$ at $T = 0K$

$$f(\varepsilon) = 0$$

This means that $\varepsilon > \varepsilon_F$ at $0K$ the levels are completely empty. This is shown in figure 1.12.

The above discussion enables us to define Fermi energy ε_F .

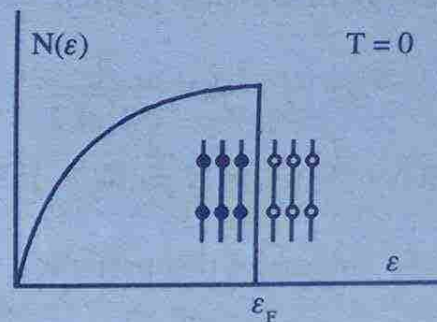

Figure 1.12: The occupation probability of electrons at $T = 0K$

The Fermi energy is the energy value upto which all the energy states are filled at 0K and above which all energy states are empty.

When $T > 0$, at $\epsilon = \epsilon_F$, we have

$$f_{FD}(\epsilon) = \frac{1}{e^{\frac{\epsilon - \epsilon_F}{kT}} + 1} = \frac{1}{e^0 + 1} = \frac{1}{2}$$

Thus the Fermi energy ϵ_F at $T > 0K$ is that energy level in which 50% of the levels are occupied and 50% are empty. This was shown in figure 1.12.

When we draw a graph between $N(\epsilon)$ and ϵ at $T > 0K$, we get graph as shown in figure 1.13.

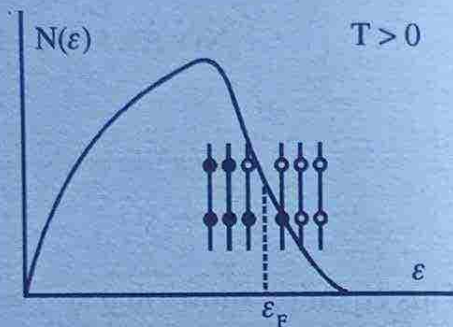

Figure 1.13: The occupation probability of electrons at $T > 0K$

Limits of classical statistics

For particles to be treated as classical it should be possible to neglect its quantum behaviour. This is possible when the de Broglie wavelength (λ) is much smaller the average separation between the particles d . i.e. for a classical particle the only criterion to be satisfied is

$$\lambda \ll d \quad \text{or} \quad \frac{\lambda}{d} \ll 1 \quad \dots (30)$$

We have $\lambda = \frac{h}{p} = \frac{h}{\sqrt{2m\epsilon}}, \quad \epsilon = \frac{p^2}{2m}$

Energy of classical particle is of the order of kT . i.e. $\epsilon \approx kT$

$$\therefore \lambda = \frac{h}{\sqrt{2mkT}}$$

When there are N particles in volume V .

The volume of one particle $= \frac{V}{N}$

i.e. $\frac{4}{3} \pi r^3 = \frac{V}{N}$, where r is the radius of the particle.

$$\therefore r^3 = \frac{3}{4\pi} \left(\frac{V}{N} \right) \approx \frac{1}{4} \frac{V}{N}$$

$$r \approx \left(\frac{1}{4} \right)^{\frac{1}{3}} \left(\frac{V}{N} \right)^{\frac{1}{3}}$$

\therefore The separation between the particles

$$d = 2r = 2 \left(\frac{1}{4} \right)^{\frac{1}{3}} \left(\frac{V}{N} \right)^{\frac{1}{3}}$$

or

$$d \approx \left(\frac{V}{N} \right)^{\frac{1}{3}}$$

Putting the value of λ and d in equation (30)

we get

$$\frac{h}{\sqrt{2mkT}} \left(\frac{N}{V} \right)^{\frac{1}{3}} \ll 1 \quad \dots (31)$$

This is the condition to be satisfied for treating the particle as classical. Recall our expression for normal constant A^{-1} from Maxwell-Boltzmann distribution.

$$A^{-1} = \frac{Nh^3}{V(2s+1)(2\pi mkT)^{\frac{3}{2}}} \quad (\text{see eqn 19(a)})$$

From equation 31, we have (cubing it)

$$\frac{N}{V} \frac{h^3}{(2mkT)^{\frac{3}{2}}} \ll 1$$

This gives us $A^{-1} \ll 1 \quad \dots (27)$

This says that the normalisation constant of the Maxwell-Boltzmann distribution must be very small for the validity of the condition for classical particles. In other words the number of occupied states in the gas is much smaller than the number of available states.

Note: A rigorous mathematical derivation shows that the de-Broglie wavelength is

$$\lambda = \frac{h}{\sqrt{2\pi mkT}}, \text{ using this we get the exact result.}$$

Example 13

Check whether the Maxwell-Boltzmann statistics can be applied to the following

- (i) A nitrogen gas at standard temperature ($T = 293 \text{ K}$) and pressure $1.0 \times 10^5 \text{ Nm}^{-2}$
 (ii) Liquid water at room temperature 27°C .

Solution

(i) $P = 1.0 \times 10^5 \text{ Nm}^{-2}$, $T = 293 \text{ K}$, $m_{\text{N}_2} = 28u$ $1u = 1.66 \times 10^{-27} \text{ kg}$

Using $PV = NkT$, we get

$$\frac{N}{V} = \frac{P}{kT} = \frac{1 \times 10^5}{1.38 \times 10^{-23} \times 293} = 2.47 \times 10^{25}$$

For Maxwell-Boltzmann statistics to be applied $\frac{h}{\sqrt{2mkT}} \left(\frac{N}{V} \right)^{1/3}$ must be very much less than one.

$$\frac{\lambda}{d} = \frac{h}{\sqrt{2mkT}} \left(\frac{N}{V} \right)^{1/3} = \frac{6.64 \times 10^{-34} \times (2.47 \times 10^{25})^{1/3}}{\sqrt{2 \times 28 \times 1.66 \times 10^{-27} \times 1.38 \times 10^{-23} \times 293}}$$

$$\frac{\lambda}{d} = \frac{6.64 \times 10^{-34} \times 2.91 \times 10^8}{193.87 \times 10^{-25}} = \frac{6.64 \times 2.91 \times 10^{-26}}{193.87 \times 10^{-25}}$$

$$\frac{\lambda}{d} = \frac{6.64 \times 0.291}{193.87} = 0.0099 \approx 0.01$$

Since $\frac{\lambda}{d} \ll 1$, it is possible to apply MB statistics.

(ii) For water $\frac{N}{V} = \frac{N}{m/d} = \frac{Nd}{m}$

$d = 10^3 \text{ kgm}^{-3}$, $m = 18u = 18 \times 1.66 \times 10^{-27} \text{ kg}$ and $N = 1$ (one molecule)

$$\therefore \frac{N}{V} = \frac{10^3}{18 \times 1.66 \times 10^{-27}} = 3.25 \times 10^{28}$$

$$\therefore \frac{\lambda}{d} = \frac{h}{\sqrt{2mkT}} \left(\frac{N}{V} \right)^{1/3}$$

$$\frac{\lambda}{d} = \frac{6.64 \times 10^{-34} \times (3.35 \times 10^{28})^{1/3}}{(2 \times 18 \times 1.66 \times 10^{-27} \times 1.38 \times 10^{-23} \times 300)^{1/2}}$$

$$\frac{\lambda}{d} = \frac{6.64 \times 10^{-34} \times 3.22 \times 10}{157.3 \times 10^{-25}}$$

$$\frac{\lambda}{d} = \frac{21.38 \times 10^{-25}}{157.3 \times 10^{-25}} = \frac{21.38}{157.3} = 0.14$$

Since $\frac{\lambda}{d}$ is not very much than one, so MB statistics cannot be applicable to liquid water at 27°C.

Example 14

For what temperatures are the atoms in an ideal gas at pressure P quantum mechanical. $P = 1.0 \times 10^5 \text{ Nm}^{-2}$. Take H_2 gas.

Solution

We have $\frac{h}{\sqrt{2mkT}} \left(\frac{N}{V} \right)^{1/3} \gg 1$ squaring on both sides, we get

$$\frac{h^2}{2mkT} \left(\frac{N}{V} \right)^{2/3} \gg 1$$

or $T \ll \frac{h^2}{2mk} \left(\frac{N}{V} \right)^{2/3}$

Using $PV = NkT$ gives $\frac{N}{V} = \frac{P}{kT}$

$$T \ll \frac{h^2}{2mk} \left(\frac{P}{kT} \right)^{2/3}$$

$$T^{3/2} \ll \frac{h^2 P^{2/3}}{2mk^{2/3}}$$

or
$$T \ll \frac{h^6 P^2}{(2m)^{3/2} k}$$

Substituting the values of h, P, m and k

$$T \ll \frac{(6.64 \times 10^{-34})^6 (10^5)^2}{(2 \times 2 \times 1.66 \times 10^{-27})^{3/2} \times 1.38 \times 10^{-23}}$$

$$T \ll \frac{(66.4)^6 \times 10^{-42} \times 100}{(4 \times 0.0166) \times 10^{-15} \times 1.38 \times 10^{-23}}$$

$$T \ll \frac{(66.4)^6 \times 10^{-40}}{(4 \times 0.166)^{3/2} \times 1.38 \times 10^{-38}}$$

$$T \ll \frac{(66.4)^6 \times 10^{-2}}{(4 \times 0.166)^{3/2} \times 1.38}$$

$$T \ll \frac{153.7 \times 10^{-2}}{0.782 \times 1.38} = \frac{1.537}{0.782 \times 1.38}$$

$$T \ll 1.42\text{K}$$

This shows that only when the temperature is very much below 1.42K, hydrogen gas can be treated as quantum mechanical. i.e. at ordinary temperatures it is a classical system.

Applications of Bose-Einstein statistics

Black body radiation

The electromagnetic radiation trapped in a cavity and in thermal equilibrium with the walls of the cavity are termed as black body radiation. In thermal equilibrium condition, the black body radiation can be considered as the photon gas. Photons have spin 1, so they are bosons and obey Bose-Einstein statistics.

The number of photon having energy between ϵ and $\epsilon + d\epsilon$, according to Bose-Einstein distribution is given by

$$N(\epsilon)d\epsilon = Vg(\epsilon)f_{BE}(\epsilon)d\epsilon$$

The density of state $g(\epsilon) = \frac{8\pi\epsilon^2}{h^3c^3}$ (see eqn 14)

and the distribution function $f_{BE}(\epsilon) = \frac{1}{A_{BE}e^{\frac{\epsilon}{kT}} - 1}$

In the case of photons, the normalisation constant has no relevance since photon number is not conserved in nature. So we set $A_{BE} = 1$.

Thus $N(\epsilon)d\epsilon = \frac{V8\pi\epsilon^2}{h^3c^3} \cdot \frac{d\epsilon}{e^{\frac{\epsilon}{kT}} - 1}$

since each photon has energy ϵ , the energy carried by $N(\epsilon)$ photon is

$$\epsilon N(\epsilon)d\epsilon = \frac{V8\pi\epsilon^3}{h^3c^3} \frac{d\epsilon}{e^{\frac{\epsilon}{kT}} - 1}$$

or $\frac{\epsilon N(\epsilon)d\epsilon}{V} = \frac{8\pi\epsilon^3}{h^3c^3} \frac{d\epsilon}{e^{\frac{\epsilon}{kT}} - 1}$

since $\frac{\text{Total energy}}{\text{Volume}} = \text{Energy density } u(\epsilon)$

$$\therefore u(\epsilon)d\epsilon = \frac{8\pi\epsilon^3}{h^3c^3} \frac{d\epsilon}{e^{\frac{\epsilon}{kT}} - 1} \quad \dots (32)$$

From this the total energy density over all photon energies can be calculated by integrating the above equation.

$$\text{i.e. } u = \int_0^{\infty} u(\epsilon)d\epsilon = \frac{8\pi}{h^3c^3} \int_0^{\infty} \frac{\epsilon^3 d\epsilon}{e^{\frac{\epsilon}{kT}} - 1} \quad \dots (33)$$

put $\frac{\epsilon}{kT} = x$

and $d\epsilon = kTdx$ in the above integral,

$$\int_0^{\infty} \frac{(kT)^3 x^3 (kT) dx}{e^x - 1} = (kT)^4 \int_0^{\infty} \frac{x^3 dx}{e^x - 1}$$

The integral can be easily calculated to be $\frac{\pi^4}{15}$ (see example 15)

$$\therefore u = \frac{8\pi^5 (kT)^4}{15h^3 c^3} = \frac{8\pi^5 k^4 T^4}{15h^3 c^3} \quad \dots (34)$$

From this we can calculate the radiant intensity R which is the radiation energy emitted per unit area per second.

$$\text{Radiant intensity, } R = \frac{c}{4} u.$$

$$\therefore R = \frac{c}{4} \frac{8\pi^5 k^4}{15h^3 c^3} T^4$$

$$R = \frac{2\pi^5 k^4}{15h^3 c^2} T^4 = AT^4$$

$$\text{where } A = \frac{2\pi^5 k^4}{15h^3 c^2}$$

Substituting the values of k , h and c we get $A = 5.67 \times 10^{-8} \text{ Wm}^{-2} \text{ K}^{-4}$.

This is the famous Stefan's constant denoted by σ

$$\therefore R = \sigma T^4 \quad \dots (35)$$

This is nothing but Stefan's law.

The above discussion shows that Bose-Einstein's statistics is in perfect agreement with Stefan's law.

From equation 32, we can easily arrive at Planck's radiation law.

Put $\epsilon = hv$ in equation 32, we get

$$u(\nu) d\nu = \frac{8\pi (h\nu)^3}{h^3 c^3} \frac{h d\nu}{e^{\frac{h\nu}{kT}} - 1}$$

$$u(\nu)d\nu = \frac{8\pi h\nu^3}{c^3} \frac{d\nu}{e^{\frac{h\nu}{kT}} - 1} \quad \dots (36)$$

This is the famous Planck's radiation law for black body radiation.

Planck's law in terms of wavelength

We have
$$u(\nu)d\nu = \frac{8\pi h\nu^3}{c^3} \frac{d\nu}{e^{\frac{h\nu}{kT}} - 1}$$

Using $\nu = \frac{c}{\lambda}$ and $d\nu = -\frac{c}{\lambda^2}d\lambda$

$$\therefore u(\lambda)d\lambda = \frac{8\pi h}{c^3} \cdot \frac{c^3}{\lambda^3} \cdot \frac{c}{\lambda^2} \frac{d\lambda}{e^{\frac{hc}{\lambda kT}} - 1}$$

$$u(\lambda)d\lambda = \frac{8\pi hc\lambda^{-5}}{e^{\frac{hc}{\lambda kT}} - 1} d\lambda \quad \dots (37)$$

This is the Planck's radiation law in terms of wavelength.

The Planck's radiation law which is in perfect agreement with experimental results. Now we proved that Planck's radiation law can also be derived using Bose-Einstein statistics. It may also be remembered that Max-Planck derived his radiation law two decades before the development of Bose-Einstein statistics.

Example 15

Show that
$$\int_0^{\infty} \frac{x^3}{e^x - 1} dx = \frac{\pi^4}{15}$$

Solution

$$\int_0^{\infty} \frac{x^3}{e^x - 1} dx = \int_0^{\infty} x^3 (e^x - 1)^{-1} dx = \int_0^{\infty} x^3 e^{-x} (1 - e^{-x})^{-1} dx$$

since $e^{-x} < 1$, we can use Binomial expansion

$$= \int_0^{\infty} x^3 e^{-x} (1 + e^{-x} + e^{-2x} + e^{-3x} + \dots) dx$$

$$= \int_0^{\infty} x^3 (e^{-x} + e^{-2x} + e^{-3x} + \dots) dx$$

$$= \int_0^{\infty} x^3 \sum_{m=1}^{\infty} e^{-mx} dx$$

$$= \sum_{m=1}^{\infty} \int_0^{\infty} x^3 e^{-mx} dx$$

Using the standard integral $\int_0^{\infty} x^n e^{-ax} dx = n!(a)^{-n-1}$

$$\begin{aligned} \therefore \int_0^{\infty} \frac{x^3}{1-e^{-x}} dx &= \sum_{m=1}^{\infty} 3!(m)^{-3-1} = 6 \sum_{m=1}^{\infty} \frac{1}{m^4} \\ &= 6 \cdot \frac{\pi^4}{90} \quad \left(\because \sum_{m=1}^{\infty} \frac{1}{m^4} = \frac{\pi^4}{90} \right) \\ &= \frac{\pi^4}{15} \end{aligned}$$

Example 16

Calculate the number of photons per cm^3 in a volume filled with radiation at

$$300\text{K} \text{ given } \int_0^{\infty} \frac{x^2}{e^x - 1} dx = 2.404.$$

Solution

The number of photons having frequencies between ν and $\nu + d\nu$ in volume V is given by

$$n(\nu)d\nu = \frac{8\pi V}{c^3} \frac{\nu^2 d\nu}{\left(e^{\frac{h\nu}{kT}} - 1 \right)} \quad (\text{see eqn 32, where } \epsilon = h\nu)$$

\therefore The total number of photons per unit volume and with all possible frequencies (0 to ∞).

$$N = \frac{1}{V} \int_0^{\infty} n(v) dv = \frac{8\pi}{c^3} \int_0^{\infty} \frac{v^2 dv}{\left(e^{\frac{hv}{kT}} - 1 \right)}$$

put $\frac{hv}{kT} = x$ and $\frac{hdv}{kT} = dx$

$$\therefore N = \frac{8\pi}{c^3} \int_0^{\infty} \left(\frac{kT}{h} \right)^3 \frac{x^2 dx}{e^x - 1} = \frac{8\pi}{c^3} \left(\frac{kT}{h} \right)^3 \int_0^{\infty} \frac{x^2 dx}{e^x - 1}$$

or
$$N = \frac{8\pi(kT)^3}{c^3 h^3} \times 2.404$$

$$= \frac{19.23 \times 3.14 \times (1.38 \times 10^{-16})^3 (300)^3}{(3 \times 10^{10})^3 \times (6.62 \times 10^{-27})^3}$$

$$= 5.4 \times 10^8 \text{ cm}^{-3}.$$

Example 17

Sunlight arrives at the earth at the rate of about 1.4 kWm^{-2} . The average radius of the earth's orbit is $1.5 \times 10^{11} \text{ m}$ and the radius of the sun is $7 \times 10^8 \text{ m}$. Calculate the surface temperature of the sun.

Solution

The solar energy received per second per unit area $= 1.4 \times 10^3 \text{ Wm}^{-2}$

\therefore The total solar energy received per second by area of a sphere whose radius r_e is that of earth's orbital radius is $4\pi r_e^2$.

$$= 1.4 \times 10^3 \times 4\pi r_e^2$$

$$= 1.4 \times 10^3 \times 4 \times 3.14 \times 1.5 \times 10^{11}$$

$$= 3.96 \times 10^{26} \text{ W} \quad \dots\dots (1)$$

This is equal to the total energy radiated by the sun per second.

According to Stefans law, the energy radiated by a perfect black body per second per unit area

$$R = \sigma T^4$$

∴ The total energy radiated by the sun per second

$$\begin{aligned}
 &= 4\pi r_s^2 \sigma T^4 \\
 &= 4\pi (7 \times 10^8)^2 \times 5.67 \times 10^{-8} T^4 \\
 &= 3489.55 \times 10^8 T^4 \quad \dots\dots (2)
 \end{aligned}$$

Equating eqns 1 and 2, we get

$$3489.55 \times 10^8 T^4 = 3.96 \times 10^{26}$$

$$\text{or } T^4 = \frac{3.96 \times 10^{26}}{3489.55 \times 10^8} = 1.1348 \times 10^{15}$$

$$T^4 = 1134.8 \times 10^{12}$$

$$T = (1134.8 \times 10^{12})^{\frac{1}{4}} = 5.8 \times 10^3 \text{ K.}$$

Example 18

What is the average energy of photons in eV present in 1 cm^3 of radiation at 727°C .

Solution

We have, the total energy per unit volume is

$$u = \frac{8\pi^5 k^4 T^4}{15 c^3 h^3} \quad (\text{see eqn 34}) \quad \dots\dots (1)$$

Total number of photons per unit volume is

$$N = \frac{8\pi k^3 T^3}{c^3 h^3} \times 2.404 \quad (\text{see example 16}) \quad \dots\dots (2)$$

∴ Average energy of photons

$$\begin{aligned}
 \bar{u} &= \frac{u}{N} = \frac{\pi^4 k T}{15 \times 2.404} \\
 &= \frac{(3.14)^4 \times 1.38 \times 10^{-16} \times 1000}{15 \times 2.404} \\
 &= 3.72 \times 10^{-13} \text{ ergs.}
 \end{aligned}$$

$$\bar{u} = \frac{3.72 \times 10^{-13}}{1.6 \times 10^{-12}} \text{ eV} = 0.2325 \text{ eV.}$$

Example 19

A black body is radiating at a temperature of $2.50 \times 10^3 \text{ K}$. a) What is the total energy density of radiation. b) What fraction of the energy is emitted in the interval between 1.00 and 1.05 eV.

Solution

a) $T = 2.50 \times 10^3 \text{ K}$.

Total energy density of radiation is

$$u = \frac{8\pi^5 k^4}{15h^3 c^3} T^4$$

$$u = \frac{8 \times (3.14)^5 \times (1.38 \times 10^{-23})^4 \times (2.5 \times 10^3)^4}{15 \times (6.64 \times 10^{-34})^3 \times (3 \times 10^8)^3}$$

$$u = \frac{8 \times (3.14)^5 \times (1.38)^4 \times (2.5)^4 \times 10^{-80}}{15 \times (6.64)^3 \times 3^3 \times 10^{-78}}$$

$$u = \frac{8 \times (3.14)^5 \times (1.38)^4 \times (2.5)^4 \times 10^{-2}}{15 \times (6.64)^3 \times 3^3}$$

$$u = \frac{3459.5}{118.57 \times 10^3} = 2.91 \times 10^{-2}$$

$$u = 0.0291 \text{ J m}^{-3}$$

$$u = \frac{0.0291}{1.6 \times 10^{-19}} \text{ eV m}^{-3}$$

$$u = 1.82 \times 10^{17} \text{ eV m}^{-3}$$

b) $T = 2.5 \times 10^3 \text{ K}$, $\epsilon = 1.00 \text{ eV}$, $d\epsilon = 0.05 \text{ eV}$

The energy emitted in the interval

$$u(\epsilon)d\epsilon = \frac{8\pi}{h^3 c^3} \frac{\epsilon^3}{e^{\frac{\epsilon}{kT}} - 1} d\epsilon$$

$$kT = 8.625 \times 10^{-5} \times 2.5 \times 10^3 \text{ eV} = 0.216 \text{ eV}$$

$$\therefore u(\epsilon)d\epsilon = \frac{8 \times 3.14 \times (1\text{eV})^3 \times 0.05\text{eV}}{(1240 \text{ eVnm})^3 \left(e^{\frac{1}{0.216}} - 1 \right)}$$

$$u(\epsilon)d\epsilon = \frac{25.12}{1.24^3 (\text{nm} \times 10^{-3})^3} \frac{\text{eV}}{101.48}$$

$$= \frac{25.12}{1.24^3 (10^{-6})^3 \text{m}^3} \frac{\text{eV}}{101.48}$$

$$= 6.49 \times 10^{15} \text{eVm}^{-3}$$

$$\therefore \text{The fraction, } \frac{u(\epsilon)d\epsilon}{u} = \frac{6.49 \times 10^{15}}{1.82 \times 10^{17}} = 0.036$$

Applications of Fermi-Dirac statistics

The most important application of the Fermi-Dirac statistics is in predicting the behaviour of free electrons inside metals. These electrons are responsible for the high conductivities of metals like copper, silver, gold etc. These electrons freely move about inside the metal, colliding against the fixed ions. Thus they form a sort of gas known as an electron gas. Since the electrons are fermions they obey Fermi-Dirac statistics.

According to Fermi-Dirac statistics, the number of electrons having energy between ϵ and $\epsilon + d\epsilon$ is given by

$$N(\epsilon)d\epsilon = Vg(\epsilon)f_{\text{FD}}(\epsilon)d\epsilon$$

$$\text{The density of states } g(\epsilon) = \frac{8\pi\sqrt{2}m^{\frac{3}{2}}\epsilon^{\frac{1}{2}}}{h^3} \text{ (see eqn 12 where } s = \frac{1}{2} \text{)}$$

$$\text{The distribution function } f_{\text{FD}}(\epsilon) = \frac{1}{e^{\frac{\epsilon - \epsilon_F}{kT}} + 1}$$

$$\therefore N(\epsilon)d\epsilon = V \frac{8\sqrt{2}\pi m^{\frac{3}{2}} \epsilon^{\frac{1}{2}}}{h^3} \frac{d\epsilon}{e^{\frac{\epsilon - \epsilon_F}{kT}} + 1} \quad \dots (38)$$

This is known as Fermi-Dirac distribution law of electrons.

Expression for Fermi energy (ϵ_F)

The Fermi energy is defined at 0K. At $T = 0K$, the distribution function

$$f_{FD}(\epsilon) = 1 \quad \text{for } \epsilon < \epsilon_F$$

$$= 0 \quad \text{for } \epsilon > \epsilon_F$$

Integrating equation 38, we get the total number of particles.

i.e.,
$$N = \int_0^{\epsilon_F} \frac{V8\sqrt{2}\pi m^{\frac{3}{2}} \epsilon^{\frac{1}{2}}}{h^3} d\epsilon$$

At $T = 0K$, the minimum energy of the particle is 0 and its maximum value is ϵ_F

$$N = \frac{V8\sqrt{2}\pi m^{\frac{3}{2}}}{h^3} \int_0^{\epsilon_F} \epsilon^{\frac{1}{2}} d\epsilon$$

$$N = \frac{V8\sqrt{2}\pi m^{\frac{3}{2}}}{h^3} \left. \frac{\epsilon^{\frac{3}{2}}}{\frac{3}{2}} \right|_0^{\epsilon_F}$$

$$N = \frac{16\sqrt{2}Vm^{\frac{3}{2}}}{3h^3} \epsilon_F^{\frac{3}{2}} \quad \dots (39)$$

or
$$\epsilon_F^{\frac{3}{2}} = \frac{3Nh^3}{16\sqrt{2}Vm^{\frac{3}{2}}} = \frac{h^3}{2^{\frac{3}{2}}m^{\frac{3}{2}}} \left(\frac{3N}{8\pi V} \right)$$

or
$$\epsilon_F = \frac{h^2}{2m} \left(\frac{3N}{8\pi V} \right)^{\frac{2}{3}} \quad \dots (40)$$

This is the expression for Fermi energy of electron system

Average electron energy at absolute zero (0K)

To calculate the average energy at 0K, first all we have to calculate the total energy E possessed by the electrons at 0K.

Total energy at 0K,
$$E = \int_0^{\epsilon_F} \epsilon N(\epsilon) d\epsilon$$

Substituting for $N(\epsilon)d\epsilon$ from equation 38 by putting $T = 0K$, we get

$$N(\epsilon)d\epsilon = \frac{V8\sqrt{2}\pi m^{\frac{3}{2}}}{h^3} d\epsilon$$

$$E = \int_0^{\epsilon_F} \frac{\epsilon V8\sqrt{2}\pi m^{\frac{3}{2}}}{h^3} d\epsilon$$

$$E = \frac{V8\sqrt{2}\pi m^{\frac{3}{2}}}{h^3} \int_0^{\epsilon_F} \epsilon^2 d\epsilon$$

$$E = \frac{V8\sqrt{2}\pi m^{\frac{3}{2}}}{h^3} \left. \frac{\epsilon^{\frac{3}{2}}}{5/2} \right|_0^{\epsilon_F}$$

$$E = \frac{16\sqrt{2}}{5} \frac{V\pi m^{\frac{3}{2}}}{h^3} \epsilon_F^{\frac{5}{2}} \quad \dots (41)$$

Eq 41
Eq 39 gives

$$\frac{E}{N} = \frac{3}{5} \epsilon_F$$

$$\frac{E}{N} = \frac{\text{Total energy}}{\text{Total number}} = \bar{\epsilon}_0, \text{ average energy per electron.}$$

Thus $\bar{\epsilon}_0 = \frac{3}{5} \epsilon_F$.

Example 20

In copper there is one free electron per atom. Calculate the Fermi energy of free electrons in copper.

Given : Atomic weight of copper 63.5 g/mole

Density of copper = $8.94 \times 10^3 \text{ g cm}^{-3}$

Avagadro number = 6.02×10^{23} atoms/mole

Solution

Number density of free electrons in copper
 = Number of atoms per cm^3 .

$$\text{i.e., } \frac{N}{V} = \frac{6.02 \times 10^{23}}{63.5} \times 8.94 = 8.48 \times 10^{22} \text{ electrons cm}^{-3}$$

$$\frac{N}{V} = 8.48 \times 10^{28} \text{ electrons m}^{-3}.$$

$$\text{Using } \epsilon_F = \frac{h^2}{2m} \left(\frac{3N}{8\pi V} \right)^{\frac{2}{3}}$$

$$\epsilon_F = \frac{(6.62 \times 10^{-34})^2}{2 \times 9.1 \times 10^{-31}} \left(\frac{3 \times 8.48 \times 10^{28}}{8 \times 3.14} \right)^{\frac{2}{3}}$$

$$= 1.13 \times 10^{-18} \text{ J} = \frac{1.13 \times 10^{-18}}{1.6 \times 10^{-19}} \text{ eV}$$

$$= 7.06 \text{ eV.}$$

Example 21

Fermi energy of conduction electrons in silver is 5.48 eV. Calculate the number of such electrons per m^3 .

Solution

$$\text{We have } \epsilon_F = \frac{h^2}{2m} \left(\frac{3N}{8\pi V} \right)^{\frac{2}{3}}$$

$$\text{or } \epsilon_F^{\frac{3}{2}} = \frac{h^3}{(2m)^{\frac{3}{2}}} \frac{3N}{8\pi V}$$

$$\therefore \frac{N}{V} = \frac{8\pi}{3h^3} (2m)^{\frac{3}{2}} \epsilon_F^{\frac{3}{2}}$$

$$= \frac{8 \times 3.14 \times (2 \times 9.1 \times 10^{-31})^{\frac{3}{2}} \times (5.48 \times 1.6 \times 10^{-19})^{\frac{3}{2}}}{3(6.62 \times 10^{-34})^3}$$

$$\text{or } \frac{N}{V} = 5.9 \times 10^{28} \text{ m}^{-3}.$$

Example 22

A certain metal has Fermi energy 3.00 eV. Find the number of electrons per unit volume with energy between 5.00 eV and 5.10 eV for $T = 295 \text{ K}$.

Solution

$$\frac{N(\epsilon)d\epsilon}{V} = \frac{8\pi\sqrt{2}m^{\frac{3}{2}}}{h^3} \epsilon^{\frac{1}{2}} \frac{d\epsilon}{e^{\frac{\epsilon-\epsilon_F}{kT}} + 1}$$

$$\frac{\epsilon - \epsilon_F}{kT} = \frac{5 - 3}{8.625 \times 10^{-5} \times 295} = 80,$$

$$\therefore e^{\frac{\epsilon - \epsilon_F}{kT}} = e^{80} = 5.54 \times 10^{34} \text{ and } d\epsilon = 5.10 - 5.00 \text{ eV} = 0.10 \text{ eV}$$

$$\begin{aligned} \frac{N(\epsilon)d\epsilon}{V} &= \frac{8 \times 3.14 \times \sqrt{2} \times (9.1 \times 10^{-31})^{\frac{3}{2}} (5 \times 1.6 \times 10^{-19})^{\frac{1}{2}} \times 0.1 \times 1.6 \times 10^{-19}}{(6.64 \times 10^{-34})^3 \times 5.54 \times 10^{34}} \\ &= 8.81 \times 10^{-10} \text{ m}^{-3}. \end{aligned}$$

Fermi-Dirac statistics has several applications. Some of them are

- (i) to find out the radius and limiting mass of white dwarf stars
- (ii) to find out the relation between mass and radius of neutron stars
- (iii) to find out the heat capacities of dilute solutions and also that of metals.

IMPORTANT FORMULAE

1. Probability of energy, $p(\epsilon) = \frac{\sum_i N_i W_i}{N \sum_i W_i}$ where i runs over all macrostates
2. Multiplicity of macrostate, $W = \frac{N!}{\prod_{i=0} N_i}$
3. When N particles share Q integral units of energy, the total number of microstates (multiplicity), $W_{\text{total}} = \frac{(N+Q-1)!}{Q!(N-1)!}$
4. When there are g_i states and N_i number of classical particles, the number of microstates possible $W = g_i^{N_i}$
5. When there are g_i states and N_i number of bosons, the number of microstates is

$$W = \frac{(N_i + g_i - 1)!}{N_i!(g_i - 1)!}$$

6. When there are g_i states and N_i number of fermions, the number of microstates

$$W = \frac{g_i!}{N_i!(g_i - N_i)!}$$

7. The number of particles (N_n) in the system with energy ϵ_n and probability $f(\epsilon_n)$ is $N_n = d_n f(\epsilon_n)$, where d_n is the degeneracy.

Total number of particles $N = \sum_n N_n = \sum_n d_n f(\epsilon_n)$ where n runs over all discrete energy states.

8. The total number of states in the interval $d\epsilon$

$$dN = N(\epsilon)d\epsilon = Vg(\epsilon)f(\epsilon)d\epsilon$$

where $g(\epsilon)$ is the density of states.

$$N = \int_0^{\infty} N(\epsilon)d\epsilon = \int_0^{\infty} Vg(\epsilon)f(\epsilon)d\epsilon$$

9. Density of states in a gas of particles

$$g(\epsilon) = \frac{4\pi\sqrt{2}(2s+1)m^{3/2}\epsilon^{1/2}}{h^3}$$

10. Density of states in terms of momentum

$$g(\epsilon) = \frac{4\pi(2s+1)p^2 dp}{h^3} - \ln 3D$$

11. Density of states in a gas of photons

$$g(\epsilon) = \frac{8\pi\epsilon^2}{h^3 c^3}$$

12. Maxwell-Boltzmann distribution function

$$f_{MB}(\epsilon) = A^{-1} e^{-\beta\epsilon}$$

13. Maxwell-Boltzmann energy distribution law

$$N(\epsilon)d\epsilon = \frac{2N}{\sqrt{\pi}(kT)^{3/2}} \epsilon^{1/2} e^{-\frac{\epsilon}{kT}}$$

14. Maxwell-Boltzmann speed distribution law

$$N(\psi)dv = N \sqrt{\frac{2}{\pi}} \left(\frac{m}{kT}\right)^{3/2} v^2 e^{-\frac{mv^2}{2kT}} dv$$

15. Expressions for rms speed, most probable speed and average speed

$$(i) v_{rms} = \sqrt{\frac{3kT}{m}}$$

$$(ii) v_p = \sqrt{\frac{2kT}{m}}$$

$$(iii) \bar{v} = \sqrt{\frac{8kT}{m}}$$

$$v_{rms} > \bar{v} > v_p$$

16. Bose-Einstein distribution function

$$f_{BE}(\epsilon) = \frac{1}{A_{BE} e^{\frac{\epsilon}{kT}} - 1}$$

$A_{BE} = 1$ for photons.

17. Fermi-Dirac distribution function

$$f_{FD}(\epsilon) = \frac{1}{e^{\frac{\epsilon - \epsilon_F}{kT}} + 1}$$

(i) $f_{FD}(\epsilon) = 1$ for $\epsilon < \epsilon_F$ at $T = 0K$
 $= 0$ for $\epsilon > \epsilon_F$ at $T = 0K$

(ii) $f_{FD}(\epsilon) = \frac{1}{2}$ for $\epsilon = \epsilon_F$ at $T > 0K$.

18. Expression for Fermi energy of electron system

$$\epsilon_F = \frac{h^2}{2m} \left(\frac{3N}{8\pi V} \right)^{2/3}$$

19. Expression for average electron energy at absolute zero

$$\bar{\epsilon}_0 = \frac{3}{5} \epsilon_F$$

20. Condition to be satisfied to treat particle as classical

$$\frac{\lambda}{d} \ll 1, \quad \lambda = \frac{h}{\sqrt{2mkT}} \quad \text{and} \quad d = \left(\frac{N}{V} \right)^{1/3}$$

or
$$\frac{h}{\sqrt{2mkT}} \left(\frac{N}{V} \right)^{1/3} \ll 1$$

In terms of temperature:

$$T \gg \frac{h^2}{2mk} \left(\frac{N}{V} \right)^{2/3}$$

In terms of pressure:

$$P \ll \frac{(2m)^{3/2} (kT)^{5/2}}{h^3}$$

UNIVERSITY MODEL QUESTIONS

Section A

(Answer questions in two or three sentences)

Short answer type questions

1. What is statistical mechanics?
2. Write down three phenomena which essentially require statistical mechanics to explain it.
3. What is meant by statistical analysis?
4. What is meant by macroscopic property of a system?
5. What is meant by microscopic property of a system?
6. Define the macrostate of a system.
7. Define the microstate of a system.
8. Four distinguishable particles are distributed in two states. Find the total number of microstates.
9. Four indistinguishable particles obeying Pauli's exclusion principle are distributed in 5 quantum states. Find the total number of microstates possible.
10. A gas has 3 particles. How these particles can be arranged in 4 quantum states according Bose-Einstein distribution?
11. What is the physical implication of increasing multiplicity?
12. Write down the statement of the implicit postulate in statistical analysis.
13. Write down an expression for probability of occurrence of particles with energy ϵ and explain the symbols.
14. Distinguish between classical and quantum particles.
15. Write down an expression for calculating the multiplicity of each microstate in the macrostate and explain the symbols.
16. N particles share Q integral units of energy. How will you calculate the multiplicity of the system?
17. Show graphically how does the classical probability $p(\epsilon)$ vary with energy ϵ .
18. Write down the three probability distribution functions and explain the symbols.
19. Define density of states.
20. How will you calculate the number of particles N_n in a system with energy ϵ_n ? What is the total number of particles if the system is discrete?
21. Write down an expression for the total number of energy states in the interval $d\epsilon$ and explain the symbols.
22. What does MB statistics deal with?
23. What does BE statistics deal with?

24. What does FD statistics deal with?
25. Write down Maxwell-Boltzmann energy distribution law and explain the symbols.
26. Write down Maxwell-Boltzmann speed distribution law and explain the symbols.
27. Write down the mathematical condition to be satisfied for treating particle as classical.
28. What are bosons? Give three examples.
29. What are the properties of bosons?
30. What are fermions? Give three examples.
31. What are the properties of fermions.
32. Distinguish between fermions and bosons.
33. Write down the Bose-Einstein distribution law and explain the symbols.
34. What is a photon gas?
35. Write down the Planck's radiation law and explain the symbols.
36. Classify the following particles according to BE and FD statistics. Proton, neutron, electron, photon, α particle, hydrogen atom, hydrogen molecule, positron and lithium ion ${}^6_3\text{Li}^+$
37. Write down Fermi-Dirac energy distribution law for free electrons in a metal and explain the symbols.
38. Define Fermi energy.
39. For $T > 0\text{K}$ and $\epsilon = \epsilon_F$, show that probability is only 50%.
40. Write down three applications of FD statistics.

Section B

(Answer questions in a paragraph of about half a page to one page)

Paragraph / Problem type questions

1. Briefly explain the statistical analysis of a composite system.
2. Distinguish between classical and quantum statistical mechanics.
3. Show that the most probable energy in the case of Maxwell-Boltzmann distribution is $\frac{1}{2}kT$.
4. Derive an expression for v_{rms} starting from Maxwell-Boltzmann speed distribution law.
5. Derive an expression for average speed starting from Maxwell-Boltzmann speed distribution law.
6. Derive an expression for most probable speed starting from Maxwell-Boltzmann speed distribution law.
7. Explain the experimental determination of molecular speeds.
8. Derive an expression for Fermi energy.
9. Derive an expression for average Fermi energy.

10. Derive the condition for the limits of classical statistics.
11. Derive Planck's radiation law by assuming Bose-Einstein distribution law and density of states.
12. Arrive at Stefan's law using Bose-Einstein distribution law.
13. a) Considering the numbers of heads and tails, how many macrostates are there when 5 coins are tossed
 b) What is the total number of possible microstates in tossing 5 coins
 c) Find the number of microstates for each macrostate.
 [a) 6 b) 32 c) 1, 5, 10, 10, 5, 1]
14. Consider a system consisting of two particles, one with spin $s = 1$ and another with spin $s = \frac{1}{2}$. a) Considering a microstate to be an assignment of the z-component of the spins of each of the particles what is the total number of microstates of the two particle system. b) How many macrostates are there for the total spin at the two particle system. c) Find the number of states of each macrostate. [a) 6 b) 2 c) 4, 2]
15. A system containing 10 electrons. Calculate the total number of microstates possible [2¹⁰]
16. A system consists of two particles each of which has a spin of $\frac{3}{2}$. a) Assuming the particles to be distinguishable, what are the macrostates of the total spin and what is the multiplicity of each. b) What are the possible values of total spin and what is the multiplicity of each value. c) Suppose the particles behave like indistinguishable quantum particles. What is the multiplicity of the macrostates of the total spin?
 [a) 7, 16 b) 7, 5, 3, 1 c) 10]
17. In a conductor like copper, each atom provides one electron that is available to conduct electric currents. If we assume that the electrons behave like a gas of particles at room temperature with a most probable energy of 0.0252 eV. What is the density of states in interval of 1% about the most probable energy. [$\approx 2.7 \times 10^{23} \text{ m}^{-3}$]
18. A system consists of N particles that can occupy two energy levels a non-degenerate ground state and a 3 fold degenerate excited state which is at an energy of 0.25 eV above the ground state. At a temperature of 960 K, Find the number of particles in the ground state and in the excited state.

$$\begin{bmatrix} N_1 = 0.872 N \\ N_2 = 0.128 N \end{bmatrix}$$
19. A container holds one mole of helium gas at a temperature of 293 K. Calculate the mean energy of the molecules. How many molecules have energies in an interval of 0.01 times mean energy centred on mean energy?

$$\begin{bmatrix} 0.0379 \\ 3.46 \times 10^{21} \end{bmatrix}$$

20. Check whether the Maxwell-Boltzmann statistics can be applied to the following
 a) liquid helium at 4K b) conduction electrons in copper at room temperature.

[a) yes b) no]

21. What pressure must be applied to nitrogen gas at room temperature before Maxwell-Boltzmann statistics begins to fail?

[$P \approx 10^3$ atm]

22. To what temperature we must cool nitrogen gas at 1 atmospheric pressure before M.B. statistics fail.

[≈ 2.9 K]

23. Calculate the number of photons per cm^3 in a volume filled with radiation at 3K.

Given $\int_0^{\infty} \frac{x^2 dx}{e^x - 1} = 2.404$ [540 photons/ cm^3 .]

24. The human eye is most sensitive to that wavelength (λ_{max}) at which energy distribution of solar radiation shows the maximum. Calculate λ_{max} if surface temperature is 5730K.

[5.058×10^{-7} m]

25. Show that the total number of photons per unit volume of an enclosure at temperature

T is $16 \left(\frac{kT}{hc} \right)^3 \sum_{n=1}^{\infty} \frac{1}{n^3}$ starting from Planck's radiation law.

26. An object is at a temperature of 400°C . At what temperature would it radiate energy twice as fast.

[527.34°C]

27. A metal sphere 4cm in diameter whose emissivity is 0.25 is heated in a furnace to 500°C . At what rate does it radiate.

[25.42W]

28. Find the surface area of a black body that radiates 1kW when temperature is 500°C . If the black body is a sphere, what is its radius.

[6.27cm]

29. The brightest part of the spectrum of the star sirius is located at a wavelength of about 290nm. What is the surface temperature of the star.

[10^4 K]

30. The microprocessors used in computers produce heat at rates as high as 30W per cm^2 of surface area. At what temperature would a black body be if it had such a radiance.

[1517K]

31. The density of aluminium is 2.7 gcm^{-3} and its atomic mass is 26.97g/mole. The effective mass of an electron in aluminium is $0.09m_e$. Calculate Fermi energy in aluminium.

[11.8eV]

32. The Fermi energy in silver is 5.51eV. (a) What is the average energy of the free electrons in silver at 0K. b) What temperature is necessary for the average molecular energy in an ideal gas to have this value.

[3.31eV, 3.84×10^4 K]

33. Using F.D. distribution function for electrons show that in a system of electron gas at $T = 0$ all states of $\epsilon > \epsilon_F$ are unoccupied.
34. The number of conduction electrons per cm^3 is 24.2×10^{22} in beryllium and 0.91×10^{23} in cesium. If the Fermi energy of conduction electrons in Be is 14.44 eV. Calculate that in cesium. [1.587 eV]

Section C

(Answer questions in about two pages)

Long answer type questions (Essays)

- Derive an expression for density of states of particles in a gas.
- Derive Planck's radiation law using B.E. statistical distribution law. Also deduce Wein's displacement law from it.
- What is F-D statistics? Derive an expression for Fermi-Dirac distribution law of electrons.

Hints to problems

1 to 12 See book work

13. a)	H	T	$W = \frac{N!}{n_1!n_2!}$
	5	0	1
	4	1	5
	3	2	10
	2	3	10
	1	4	5
	0	5	1

Total number of macrostates = 6

Total number of microstates = $2^5 = 32$

14. a) For
- $s = 1$
- , there are
- $(2s + 1)$
- microstates = 3

For $s = \frac{1}{2}$, there are $(2s + 1)$ microstates = 2 \therefore Total number of microstates = $3 \times 2 = 6$.

- b) Two spins can combine to give either
- $1 + \frac{1}{2} = \frac{3}{2}$
- or
- $1 - \frac{1}{2} = \frac{1}{2}$
- . So there are two macrostates.

- c) For
- $s = \frac{3}{2}$
- there are
- $(2 \times \frac{3}{2} + 1) = 4$
- microstates and
- $s = \frac{1}{2}$
- , there are
- $(2 \times \frac{1}{2} + 1) = 2$
- microstates

∴ Total $4 + 2$ microstates.

15. Each electron has $(2s + 1)$ states

∴ The number of microstates possible is $(2s + 1)^{10} = 2^{10}$.

16. a) Each particle has $2s + 1 = 2 \times \frac{3}{2} + 1 = 4$ states.

∴ The total number of macrostates = $4 \times 4 = 16$

For each particle the possible states are

$$\frac{3}{2}, \frac{1}{2}, -\frac{1}{2} \text{ and } -\frac{3}{2}$$

and $\frac{3}{2}, \frac{1}{2}, -\frac{1}{2} \text{ and } -\frac{3}{2}$

The total spin of the system $s = 3$

The possible states $+3, 2, 1, 0, -1, -2$ and -3 .

		Multiplicity
7 Macrostates	3	$(\frac{3}{2}, \frac{3}{2})$ 1
	2	$(\frac{3}{2}, \frac{1}{2}) (\frac{1}{2}, \frac{3}{2})$ 2
	1	$(\frac{3}{2}, -\frac{1}{2}) (\frac{1}{2}, \frac{1}{2}) (-\frac{1}{2}, \frac{3}{2})$ 3
	0	$(\frac{3}{2}, -\frac{3}{2}) (-\frac{3}{2}, \frac{3}{2}) (\frac{1}{2}, -\frac{1}{2}) (-\frac{1}{2}, \frac{1}{2})$ 4
	-1	$(-\frac{3}{2}, \frac{1}{2}) (\frac{1}{2}, -\frac{3}{2}) (-\frac{1}{2}, -\frac{1}{2})$ 3
	-2	$(-\frac{3}{2}, -\frac{1}{2}) (-\frac{1}{2}, -\frac{3}{2})$ 2
	-3	$(-\frac{3}{2}, -\frac{3}{2})$ 1
		Total 16

b) The possible values of total spin are $s = 3, 2, 1, 0$

For $s = 3$, the multiplicity = $2s + 1 = 2 \times 3 + 1 = 7$

For $s = 2$, the multiplicity = $2s + 1 = 2 \times 2 + 1 = 5$

For $s = 1$, the multiplicity = $2s + 1 = 2 \times 1 + 1 = 3$

For $s = 0$, the multiplicity = $2s + 1 = 2 \times 0 + 1 = 1$

Total multiplicity = $7 + 5 + 3 + 1 = 16$.

c) When the particles are indistinguishable look at the table drawn for (a)

		Multiplicity
3	$(\frac{3}{2}, \frac{3}{2})$	1
2	$(\frac{3}{2}, \frac{1}{2})$	1
1	$(\frac{3}{2}, -\frac{1}{2}) (\frac{1}{2}, \frac{1}{2})$	2
0	$(\frac{3}{2}, -\frac{3}{2}) (\frac{1}{2}, -\frac{1}{2})$	2
-1	$(-\frac{3}{2}, -\frac{1}{2}) (-\frac{1}{2}, -\frac{1}{2})$	2
-2	$(-\frac{3}{2}, -\frac{3}{2})$	1
-3	$(-\frac{3}{2}, -\frac{3}{2})$	1
	<u>Total</u>	<u>10</u>

17. Using $g(\epsilon)d\epsilon = \frac{8\pi\sqrt{2}m^{3/2}\epsilon^{1/2}}{h^3}d\epsilon$

$$m = 9.1 \times 10^{-31}, \quad \epsilon = 0.0252 \text{ eV}, \quad d\epsilon = 0.0252 \times \frac{1}{100} \quad \text{and} \quad h = 6.64 \times 10^{-34}$$

18. $N \propto d e^{-\frac{\epsilon}{kT}} \quad \therefore \quad \frac{N_2}{N_1} = \frac{d_2 e^{-\frac{\epsilon_2}{kT}}}{d_1 e^{-\frac{\epsilon_1}{kT}}} \quad \frac{N_2}{N_1} = \frac{3}{1} e^{-\frac{(\epsilon_2 - \epsilon_1)}{kT}}$

$$\epsilon_2 - \epsilon_1 = 0.25 \text{ eV}$$

$$kT = 8.625 \times 10^{-5} \times 960 = 9.28 \times 10^{-2}$$

$$\frac{N_2}{N_1} = 3e^{-\frac{0.25}{9.28 \times 10^{-2}}} = 3e^{-3.019} = 0.147$$

$$N_1 + N_2 = N \quad \therefore \quad N_2 = N - N_1$$

$$\therefore \frac{N - N_1}{N_1} = 0.147 \quad \therefore \quad N_1 = 0.872N \quad \text{and} \quad N_2 = 0.128N$$

19. Mean energy, $E_m = \frac{3}{2}kT = \frac{3}{2} \times 8.625 \times 10^{-5} \times 293$
 $= 0.0379 \text{ eV}$

$$dN = N(\epsilon)d\epsilon = \frac{2N}{\sqrt{\pi}(kT)^{3/2}} \epsilon_m^{1/2} e^{-\frac{\epsilon_m}{kT}} d\epsilon$$

$$= \frac{2 \times 6.02 \times 10^{23} \times (0.0379)^{1/2}}{\sqrt{3.14}(0.02527)^{3/2}} e^{-\frac{0.0379}{0.02527}} \times 0.01 \times 0.0379$$

$$= 3.46 \times 10^{21}$$

20. See example 13.

21. M.B statistics fail when $\frac{\lambda}{d}$ is less than (say 0.1) but not very much less than 1.

$$\lambda = \frac{h}{\sqrt{2mkT}}, \quad d = \left(\frac{V}{N}\right)^{1/3}$$

Using $PV = NkT \quad \frac{V}{N} = \frac{kT}{P}$

Then calculate P, substituting, we get $P = \frac{0.1(2m)^{3/2}(kT)^{3/2}}{h^3}$

$$m_{N_2} = 28u = 28 \times 1.67 \times 10^{-27} \text{ kg}$$

22. For the validity of M.B statistics $\frac{h}{\sqrt{2mkT}} \left(\frac{N}{V}\right)^{1/3} \ll 1$, Begins to fail

$$\frac{h}{\sqrt{2mkT}} \left(\frac{N}{V}\right)^{2/3} = 0.1$$

Use $\frac{N}{V} = \frac{P}{kT}$ Find T

23. See example 1

24. $\lambda_{\max} T = 2.898 \times 10^{-3}$

25. See book work.

26. Energy radiated, $E \propto T^4$

$$\therefore \frac{E_2}{E_1} = \left(\frac{T_2}{T_1}\right)^4 \quad E_2 = 2E_1 \quad \text{given} \quad T_1 = 400 + 273 = 673\text{K.}$$

27. Energy radiated per second per unit area = $e \sigma T^4$

$$\therefore \text{Energy radiated per second} = 4\pi r^2 e \sigma T^4$$

$$= 4 \times 3.14 \times (2 \times 10^{-2})^2 \times 0.25 \times 5.67 \times 10^{-8} \times (773)^4$$

28. Energy radiated per second = $4\pi r^2 \sigma T^4$

$$10^3 = 4\pi r^2 \sigma T^4 \quad \text{or} \quad r^2 = \frac{10^3}{4\pi \times \sigma T^4} \quad r = \left(\frac{10^3}{4\pi e \sigma T^4}\right)^{\frac{1}{2}}$$

$$\sigma = 5.67 \times 10^{-8}, \quad T = 773\text{K}$$

$$29. \lambda_{\max} T = 2.898 \times 10^{-3} \quad T = \frac{2.898}{290 \times 10^{-9}} \times 10^{-3} = 1 \times 10^4 \text{K.}$$

$$30. R = \sigma T^4 \quad T = \left(\frac{R}{\sigma}\right)^{\frac{1}{4}} = \left(\frac{30 \times 10^4}{5.67 \times 10^{-8}}\right)^{\frac{1}{4}}$$

31. Same as example 20.

$$32. \text{a) } \bar{\epsilon}_0 = \frac{3}{5} \epsilon_F \quad \text{b) } 3.31\text{eV} \approx kT \quad T = \frac{3.31 \times 1.6 \times 10^{-19}}{1.38 \times 10^{-23}}$$

33. See book work

$$34. E_F \propto \left(\frac{N}{V}\right)^{\frac{2}{3}}$$

$$(E_F)_{\text{Cs}} \propto (0.9 \times 10^{22})^{\frac{2}{3}} \quad \dots\dots (1)$$

$$(E_F)_{\text{Be}} \propto (24.2 \times 10^{22})^{\frac{2}{3}} \quad \dots\dots (2)$$

$$(E_F)_{\text{Be}} = 14.44\text{eV}$$

$\frac{\text{eqn 1}}{\text{eqn 2}}$ gives the answer.

2

SOLID STATE PHYSICS

Introduction

Matter exists in three states namely solids, liquids and gases. As the atoms or molecules in solids are attached to one another with strong forces of attraction, the solids have definite volume and shape. In this unit we shall deal with physical properties of solids, particularly crystals hence called solid state physics or crystal physics. The solids may be broadly classified as crystalline and non-crystalline (amorphous).

The crystalline state of a solid is characterised by regular or periodic arrangement of atoms or molecules. The crystalline solids may be subdivided into single crystals and polycrystalline solids. In single crystals, the periodicity of atoms extends throughout the material. Diamond, quartz, mica, etc. are examples of single crystals. A polycrystalline material is an aggregate of a number of small crystallites with random orientations separated by well defined boundaries. The small crystallites are known as grains and the boundaries as grain boundaries. Polycrystalline form of a material is more stable than a single crystal. Metals and ceramics exhibit polycrystalline structure.

Amorphous solids are characterised by the random arrangement of atoms or molecules. The periodicity, if at all present, extends up to a distance of a few atomic

Table 2.1 : Distinction between crystalline and amorphous solids

Crystalline	Amorphous
1. The atoms or molecules are arranged in definite geometrical order giving definite geometrical pattern.	1. They do not possess definite geometrical pattern.
2. The atoms are arranged in long range order.	2. The atoms are arranged in short range order.
3. They have sharp melting point.	3. They do not have sharp melting point.
4. They are anisotropic. Their physical properties like electrical conductivity, refractive index, thermal conductivity etc. are different along different directions.	4. They are isotropic. Their thermal conductivity, electrical conductivity, refractive index etc. are same in different directions.

diameters only. In other words; these solids exhibit short range order. Glass, plastics, rubbers, cement, paraffin wax etc. are amorphous solids.

The science which deals with the study of geometrical forms and physical properties of crystalline solids is called crystallography. This forms the basis to the study of solid state physics.

Lattice points and space lattice

The atomic arrangements in a crystal is called a crystal structure. In a perfect crystal, there is a regular arrangement of atoms. This periodicity in the arrangement generally varies in different directions. To describe a crystal structure we have to develop a geometrical artifice. For this imagine a large number of points in space about which the atoms are located. Such points in space are called lattice points and the totality of such points forms a space lattice (crystal lattice). The arrangement of infinite number of imaginary points in three dimensional space with each point having identical surroundings is known as space lattice.

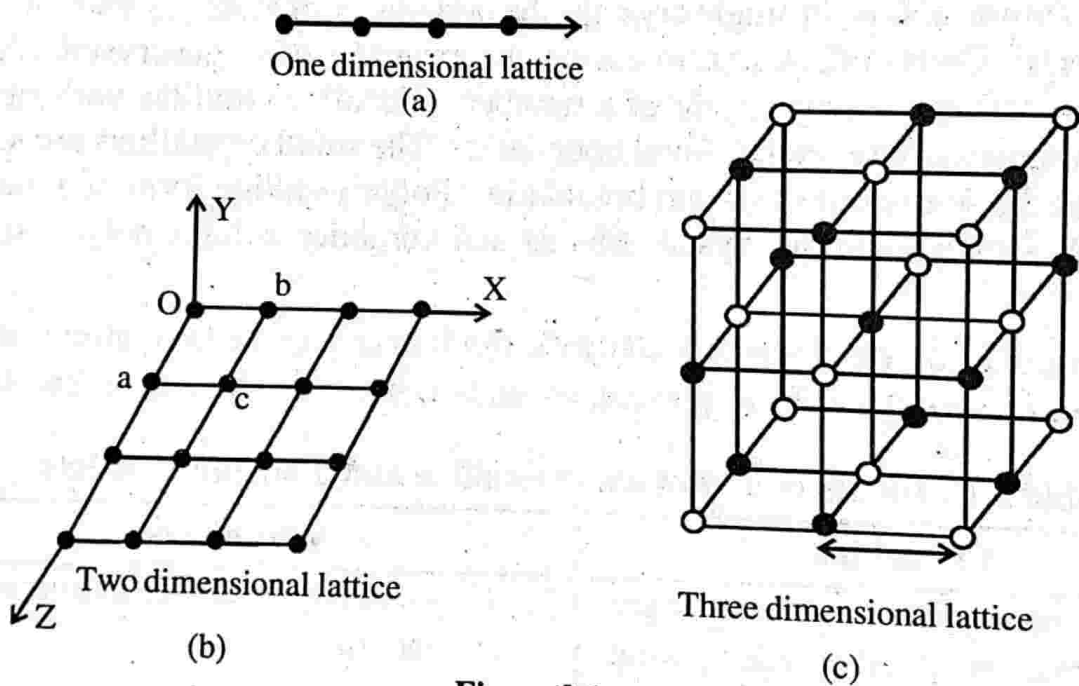

Figure 2.1

Remember that crystal lattice is purely an imaginary geometrical construction. In the definition of crystal lattice the term identical surroundings means that the lattice has the same appearance when viewed from a point \vec{r} in the lattice as it has when viewed from any other point \vec{r}' with respect to some arbitrary origin.

Let us consider the case of a two dimensional array of lattice points as shown below. It represents a space lattice since the environment about any two points is the same.

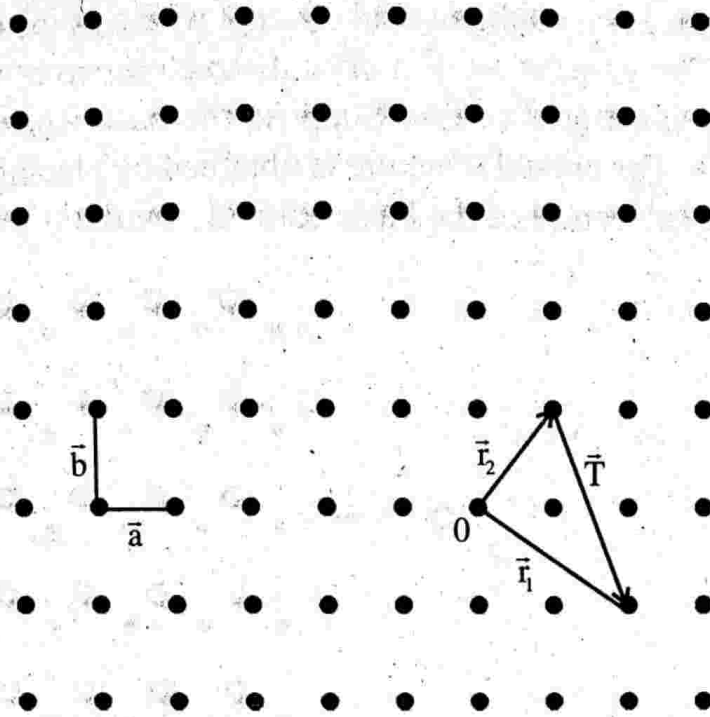

Figure 2.2

We choose an arbitrary origin 0 and position vectors \vec{r}_1 and \vec{r}_2 of any two lattice points by joining them to 0 as shown. If the difference \vec{T} of the two vectors \vec{r}_1 and \vec{r}_2 satisfies the relation.

$$\vec{T} = n_1 \vec{a} + n_2 \vec{b}$$

where n_1 and n_2 are integers and \vec{a} and \vec{b} are fundamental translation vectors characteristic of the array, then the array of points is a two dimensional lattice.

For three dimensional lattice

$$\vec{T} = n_1 \vec{a} + n_2 \vec{b} + n_3 \vec{c}.$$

The basis and crystal structure

The space lattice has been defined as an array of imaginary points which are so arranged in space that each point has identical surroundings. The crystal structure is always described in terms of atoms rather than points. Thus in order to obtain a crystal structure, an atom or a group of atoms must be placed on each lattice point in a regular fashion. Such an atom or a group of atoms is called the basis and acts as a building unit or a structural unit for the complete crystal structure. Thus a lattice combined with a basis generates the crystal structure. Mathematically it is expressed as

$$\text{Space lattice} + \text{basis} = \text{crystal structure}$$

Remember that lattice is a mathematical concept whereas the crystal structure is a physical concept. The generation of a crystal structure from a two dimensional lattice and a basis is illustrated below. Suppose the basis consists of two atoms represented by \circ and \bullet . The crystal structure is obtained by placing the basis on each lattice point such that the centre of the basis coincides with the lattice point.

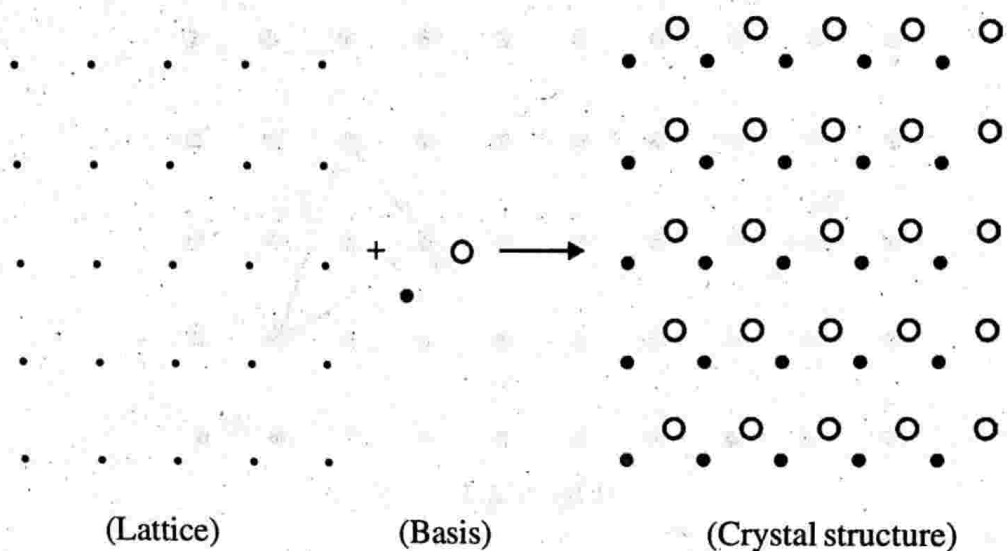

Figure 2.3

The number of atoms in a basis may vary from one to several thousands, whereas the number of space lattices possible is only fourteen. It shows that different types of basis are available. If the basis consists of a single atom only a mono atomic crystal is obtained. Copper is an example of mono atomic face centred cubic structures.

Unit cells and lattice parameters

A crystal structure is formed by the addition of basis to every lattice point. In describing crystal structures, it is often convenient to subdivide the structure into small repeat entities called unit cells. i.e., in every crystal some fundamental grouping of particles is repeated. Such fundamental grouping of particles is called a unit cell.

A unit cell is chosen to represent the symmetry of the crystal structure, where in all the atom positions in the crystal may be generated by translations of the unit cell through distances along each of its edges. Thus, unit cell is the basic building block of the crystal structure by virtue of its geometry and atomic positions within the crystal. A unit cell or more than a single unit cell may be chosen to build up a crystal structure. Unit cells also may be regarded as the building blocks that make up the crystal.

Figure below shows a unit cell and the crystal formed with the help of such unit cells.

From the figure below we can have

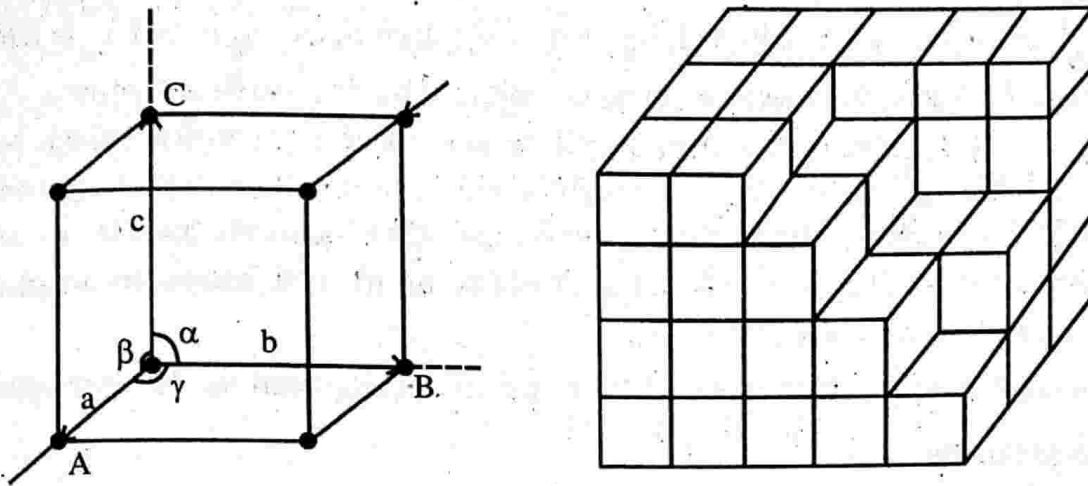

Figure 2.4

1. The line OA, OB and OC are obtained by the intersection of the adjacent faces of the unit cell. The directions parallel to these lines are called crystallographic axes.
2. The lengths of the sides $OA = a$, $OB = b$ and $OC = c$ are called lattice constants or primitives.
3. The angles α , β and γ between the crystallographic axes are called interfacial angles.

The above discussion shows that a unit cell can be completely described by the three vectors \bar{a} , \bar{b} and \bar{c} and angles between them (α , β , γ) are specified. \bar{a} , \bar{b} and \bar{c} are called lattice vectors. The lattice vectors \bar{a} , \bar{b} and \bar{c} and the interfacial angles constitute the lattice parameters of the unit cell. By knowing the lattice parameters we can easily determine the form and size of the unit cell.

It may also be noted that unit cells for most of the crystals are parallelepiped or cubes having three sets of parallel faces.

The lattice vectors \bar{a} , \bar{b} and \bar{c} may or may not be equal. Also the angles α , β and γ may or may not be right angles. Based on these conditions, there are seven different unit cells so also crystals. If atoms are existing at the corners of the unit cells, the seven unit cells yield seven crystal structures which gives seven types of lattices. More space lattices can be constructed by placing atoms at the body centres of unit cells or at the centres of faces. So we can have 14 different types of space lattices. These 14 space lattices are called Bravais lattice. Bravais is the name of the person who discovered this.

Unit cell versus primitive cell

The parallelepiped (or cube) defined by primitive axes \vec{a} , \vec{b} and \vec{c} is called a primitive cell. A primitive cell is a type of unit cell having smallest volume. All the lattice points belonging to a primitive cell lie at its corners. Therefore, the effective number of lattice points in a primitive cell is one. A unit cell on the other hand may have the lattice points at the corners as well as at other locations both inside and on the surface of the cell and therefore the effective number of lattice points in a non-primitive cell is greater than one.

A unit cell may be a primitive cell but primitive cells need not be unit cells.

Crystal systems

Crystals have internal structure. Depending on their internal structures they exhibit symmetries. Based on the symmetries exhibited by crystals they are classified into 32 classes. Among the 32 classes of crystal systems there are only seven basic crystal structures. These seven basic crystal systems are distinguished from one another by the angles between the three axes (α , β and γ) and the lattice vectors (\vec{a} , \vec{b} and \vec{c}). They are 1. Cubic crystal 2. Tetragonal crystal 3. Orthorhombic crystal 4. Monoclinic crystal 5. Triclinic crystal 6. Trigonal crystal and 7. Hexagonal crystal.

1. Cubic crystal system

In a cubic crystal the crystal axes are perpendicular to one another and the lengths of the lattice vectors are the same.

i.e., $a = b = c$ and $\alpha = \beta = \gamma = 90^\circ$

Cubic crystal may be simple cubic (sc), body centred cubic (bcc) or face centred cubic (fcc).

In the unit cell of simple cubic crystal structure the atoms are located at the corners only (each atom at each corner). Cu, Ag, Fe etc. are examples of simple cubic

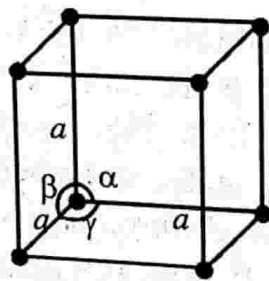

Simple cubic (sc)

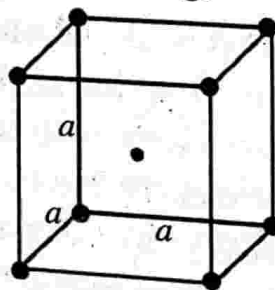

Body centred cubic (bcc)

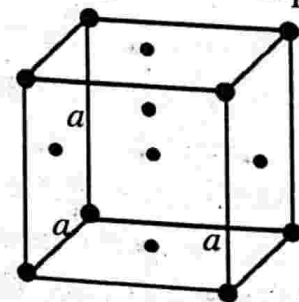

Face centred cubic (fcc)

Figure 2.5

In the unit cell of body centred cubic crystal structure there are atoms located at the corners (each atom at each corner) and another atom at the body centre. Li, Na, K and Cr exhibit this structure. In the unit cell of face centred cubic (fcc) crystal structure, there are atoms located at the corners (each one at each corner) and each atom at the centres of six faces. NaCl, is an example for fcc.

2. Tetragonal crystal system

Here $a = b \neq c$, $\alpha = \beta = \gamma = 90^\circ$

i.e., The crystal axes are perpendicular and the length of two lattice vectors are the same but the length of the third lattice is different. Tetragonal crystal may be simple or body centred. β -Sn is an example for simple tetragonal and Ti_2O_2 is an example for body centred tetragonal.

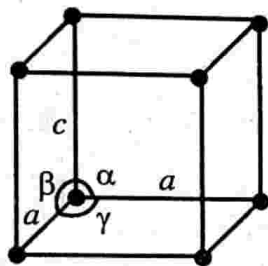

Simple tetragonal (st)

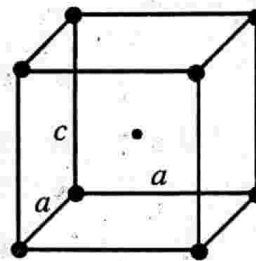

Body-centred tetragonal (bct)

Figure 2.6

3. Orthorhombic crystal system

$a \neq b \neq c$, $\alpha = \beta = \gamma = 90^\circ$

The crystal axes are perpendicular to one another but the length of the lattice vectors are different all along the three axes.

Orthorhombic crystals may be simple, base centred (end centred), body centred or face centred.

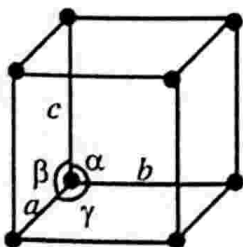

Simple orthorhombic

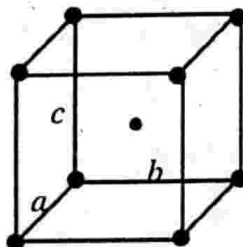

Body-centred orthorhombic

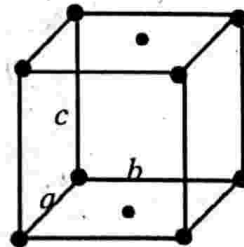

End centred orthorhombic

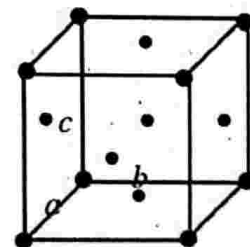

Face centred orthorhombic

Figure 2.7

4. Monoclinic crystal system

$$a \neq b \neq c, \alpha = \beta = 90^\circ \neq \gamma$$

Here two of the crystal axes are perpendicular to each other but third axis is obliquely inclined. The length of the lattice vectors are different along all the three axes. Monoclinic crystals may be simple or base centred (end centred). $\text{CaSO}_4 \cdot 2\text{H}_2\text{O}$ (gypsum) is an example for simple monoclinic.

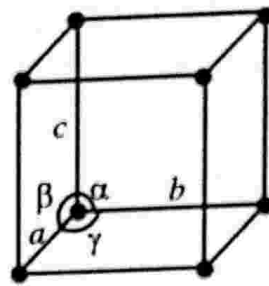

Simple monoclinic

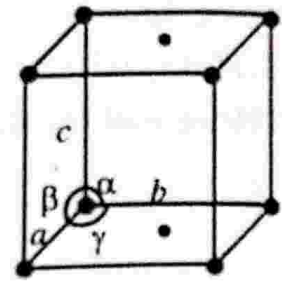

Base-centred monoclinic

Figure 2.8

5. Triclinic crystal system

$$a \neq b \neq c, \alpha \neq \beta \neq \gamma \neq 90^\circ$$

None of the crystal axes are perpendicular to any of the others and all the length of the lattice vectors are different. There is only simple triclinic crystal structure. $\text{K}_2\text{Cr}_2\text{O}_7$ is an example for this.

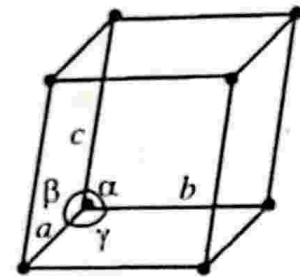

Simple triclinic

Figure 2.9

6. Trigonal (rhombohedral) crystal system

$$a = b = c, \alpha = \beta = \gamma \neq 90^\circ$$

The length of the lattice vectors are equal and are equally inclined to each other at an angle other than 90° .

There is only simple trigonal crystal structure. As, Sb, Bi etc. exhibit this structure.

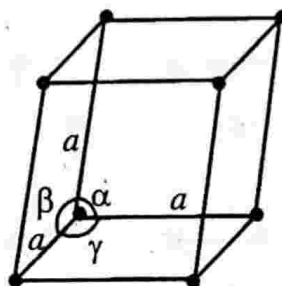

Simple rhombohedral

Figure 2.10

7. Hexagonal crystal system

$$a = b \neq c, \alpha = \beta = 90^\circ, \gamma = 120^\circ$$

Lengths of two lattice vectors are same but the length of third axis is different. Two of the crystal axes are 60° apart while the third is perpendicular to both of them. There is only simple hexagonal crystal structure. Mg, Zn, Cd etc. exhibit this structure.

The seven basic crystal structures and their properties are given in the table below.

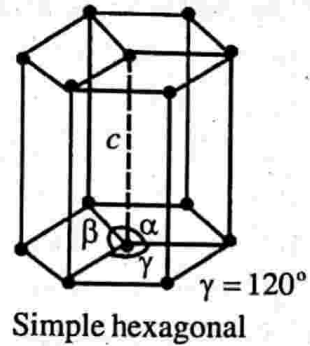

Figure 2.11

Table 2.2 : Seven basic crystal systems and their characteristics

Sl. No.	Crystal system (7)	Lattice parameters	Bravais lattice (14)	Examples
1	Cubic	$a = b = c, \alpha = \beta = \gamma = 90^\circ$	sc, bcc, and fcc	Ag, Cu, Fe Li, Na, K, Cr, NaCl
2	Tetragonal	$a = b \neq c, \alpha = \beta = \gamma = 90^\circ$	st, bct	β -Sn, TiO_2
3	Orthorhombic	$a \neq b \neq c, \alpha = \beta = \gamma = 90^\circ$	so, bco, eco, fco	$KNO_3, BaSO_4,$ $PbCO_3$
4	Monoclinic	$a \neq b \neq c, \alpha = \beta = 90^\circ \neq \gamma$	sm, ecm	$CaSO_4 \cdot 2H_2O,$ $FeSO_4, Na_2SO_4$
5	Triclinic	$a \neq b \neq c, \alpha \neq \beta \neq \gamma \neq 90^\circ$	st	$K_2Cr_2O_7, CuSO_4 \cdot 5H_2O.$
6	Trigonal	$a = b = c, \alpha = \beta = \gamma \neq 90^\circ$	sr	As, Sb, Bi, Calcite
7	Hexagonal	$a = b \neq c, \alpha = \beta = 90^\circ$ $\gamma = 120^\circ$	sh	$SiO_2, Zn, Mg, Cd.$

Crystal symmetry

All crystals have ordered arrangements of the faces and edges. i.e., we can say that crystals possess symmetries. We know that symmetry plays an important role in dictating the dynamics and properties of a system. Here the symmetry possessed by crystals acts as a powerful tool for the study of the internal structure of crystals. From this we can extract the properties of solids which are constructed from the basic crystal structures.

The symmetries possessed by crystals are described in terms of symmetry operations. A symmetry operation is that which transforms the crystals to itself. i.e., a

crystal remains invariant under a symmetry operation. These operations are translation, rotation, reflection and inversion. The last three operations are point operations and their combinations give certain symmetry elements which collectively determine the symmetry of crystal around a point. The group of such symmetry operations at a point is called a point group. There are totally 32 point groups in a 3D lattice. The group of all the symmetry elements of a crystal structure is called a space group (point group symmetry operations combined with translational symmetry elements). There are totally 230 distinct space groups in 3D lattice exhibited by crystals.

The 32 point groups in 3D produce only 14 distinct Bravais lattices. These 14 Bravais lattices can be constructed from 7 distinct crystal systems which we already explained.

The 23 symmetry elements in a cubic crystal

Here we discuss about the point symmetries exhibited by a cubic crystal. We could already see that there are three symmetries come under this. They are 1) inversion 2) reflection and 3) rotation.

Inversion symmetry of a cubic crystal

Inversion is a point operation which is applicable to 3-dimensional lattices only. This symmetry element implies that each point located at \vec{r} relative to a lattice point has an identical point located at $-\vec{r}$ relative to the same lattice point. In other words it means that the lattice possesses a centre of inversion or centre of symmetry. Consider a cubic crystal. It has three pairs of parallel and opposite faces all of them of the same size and shape. Here the body centre is a centre of symmetry. This centre lies at equal distances from various symmetrical positions. Here for every lattice point given by the position vector \vec{r} there is a corresponding lattice point at the position $-\vec{r}$. Hence we can say that cube possesses a centre of symmetry.

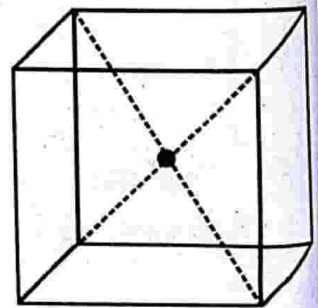

Figure 2.12

2. Reflection symmetry of a cubic crystal (plane of symmetry)

A lattice is said to possess reflection symmetry if there exists a plane (or a line in two dimensions) in the lattice which divides it into two identical halves which are mirror images of each other. In other words a crystal is said to possess reflection symmetry about a plane if it is left unchanged in every way after being reflected by the plane.

In a cubic crystal we can see there are three straight planes of symmetry parallel to the faces of the cube and six diagonal planes of symmetry (see figure below).

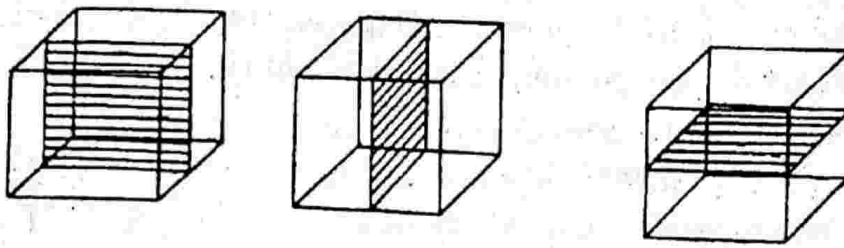

Figure 2.13 : The three planes of symmetry parallel to the faces of the cube

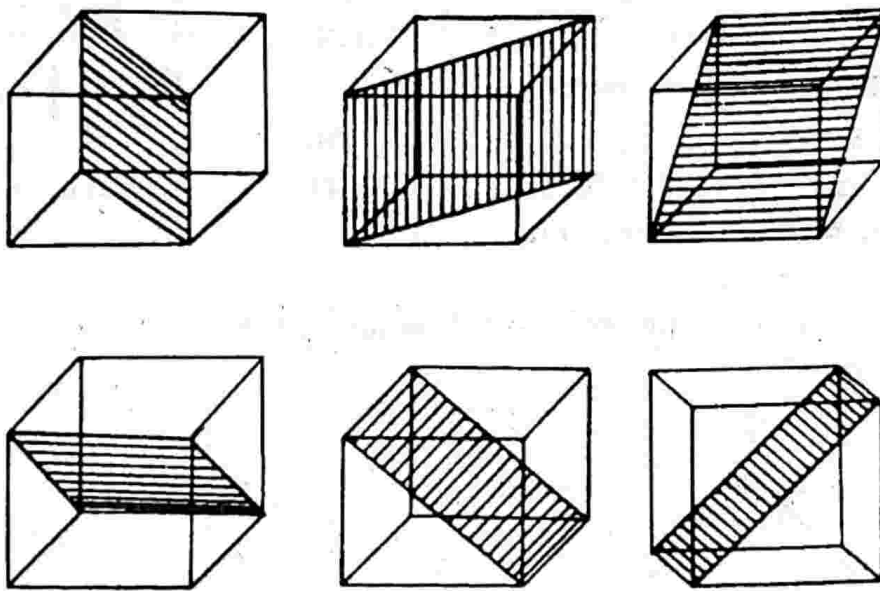

Figure 2.14: The six diagonal planes of symmetry in a cube

Note: Reflection occurs in a plane through the lattice point, while the inversion is equivalent to a reflection through a point.

Rotation symmetry of a cubic crystal

A lattice is said to possess the rotation symmetry if its rotation by an angle θ about an axis (or a point in a two dimensional lattice) transforms the lattice to itself. Since the lattice always remains invariant by a rotation of 2π , the angle 2π must be an integral multiple of θ .

i.e.,
$$n\theta = 2\pi$$

or
$$\theta = \frac{2\pi}{n}$$

The factor n takes integral values and is known as multiplicity of rotation axis. The value of n decides the fold of the axis. Only one, two, three, four and six fold rotation axes of symmetry are possible in a crystal lattice.

If a cube is rotated about a normal to one of its faces at its mid point through 90° , cube is indistinguishable from the position it occupied originally.

Thus the normal is an axis of 4 fold $\left(\frac{360}{90}\right)$ symmetry. Hence it is called a tetrad axis. A cube possesses three such axes, one normal to each of the three pairs of parallel faces. (see figure below)

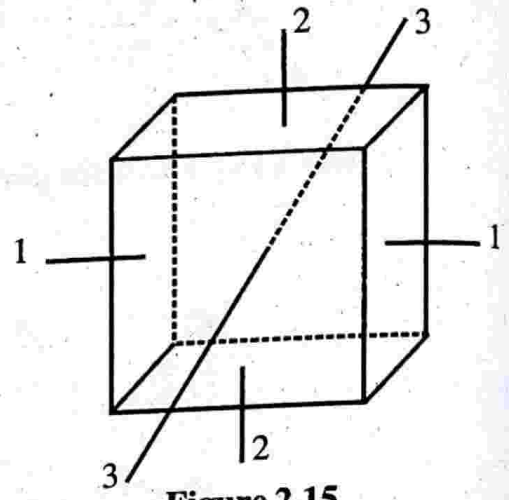
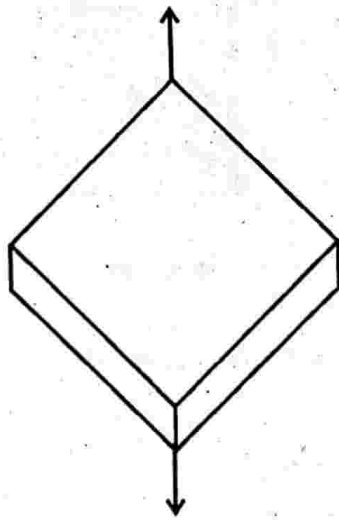

Figure 2.15

The three tetrad axis of a cube. If a cube is rotated about a body diagonal through 120° , the cube will remain invariant. Then the body diagonal is a

trid $\left(\frac{360}{120} = 3\right)$ axes. A cube possesses four such axes.



One of the traid axes of the cube

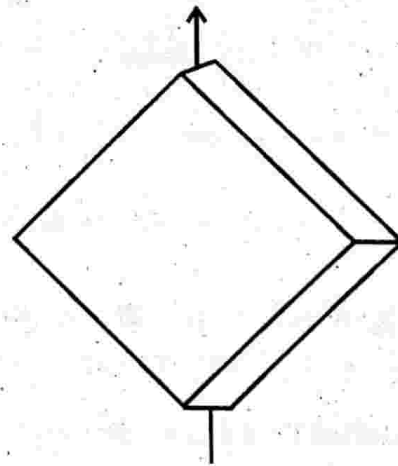

One of the diad axes of the cube

Figure 2.16

If a cube is rotated about a line joining the mid points of a pair of opposite parallel edges through 180° , the cube is indistinguishable from the position it occupied originally.

Thus the line is an axis of two $\left(\frac{360}{180} = 2\right)$ fold symmetry. Hence it is called a diad axis. A cube possesses six such axes.

To sum up, the various symmetry elements in a cubic crystal are

Inversion symmetry	- 1
Reflection symmetry	
Straight planes	- 3
diagonal planes	- 6
tetrad axes	- 3
triad axes	- 4
diad axes	- 6

∴ Total symmetry elements of a cubic crystal is 23.

Rotation - inversion axis

A crystal is said to possess a rotation - inversion axis if it is brought back to its original condition by rotation followed by an inversion about a lattice point through which the rotation axis passes.

Let us consider an axis normal to the circle passing through the centre; operating on a pole 1 to rotate it through 90° anticlockwise to the position 4, followed by an inversion to the position 2. From the position 2 the pole is rotated through 90° anticlockwise and inverted to position 3. From position 3 it is further rotated through 90° anticlockwise and inverted to position 4. Further 90° rotation and an inversion the pole resumes position 1. Crystals can possess 1-, 2-, 3-, 4- and 6- fold rotation inversion axes, represented by $\bar{1}$, $\bar{2}$, $\bar{3}$, $\bar{4}$ and $\bar{6}$.

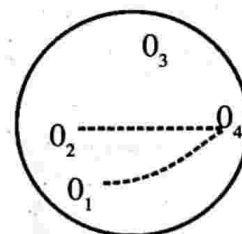

Figure 2.17

Translational symmetry elements

There are two translation symmetry elements exhibited by crystals. They are screw axis and glide planes.

Screw axis

When a rotation corresponding to 2-, 3-, 4- or 6- fold axis combines with a translation parallel to the rotation axis will give rise to a new symmetry element called the screw axis.

For example within a crystalline structure there are identical atoms a_1 , a_2 , a_3 , a_4 and a_5 as shown in figure below. t is the distance between a_1 and a_3 . This crystalline structure exhibits screw axis. The atom a_1 which is related to a_2 by a rotation

$180^\circ \left(\frac{2\pi}{2} \right)$ followed by $\frac{t}{2}$ parallel to the rotation axis. This element of symmetry is referred to as 2 – fold screw axis and is demoted by 2_1 . The ordinary 2 – fold axis is also shown in figure.

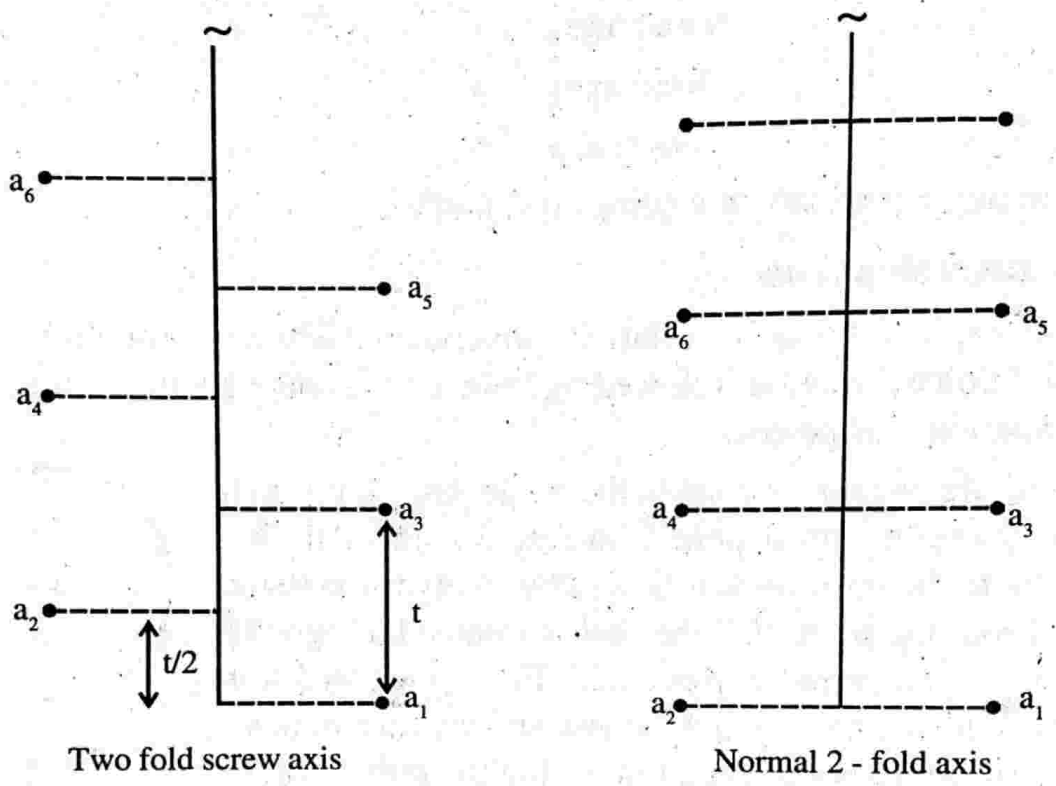

Figure 2.18

Similarly a 3 - fold axis generates 3_1 and 3_2 screw axis. 3_1 corresponds to 120° rotation about the axis followed by a translation $\frac{t}{3}$, 3_2 corresponds 120° rotation plus a translation equal to $\frac{2}{3}t$. Similarly $4_1, 4_2, 4_3$ are screw axes generated by the 4 – fold axis. The 6 – fold axis generates $6_1, 6_2, 6_3, 6_4$ and 6_5 screw axis.

In general a screw axis is represented by the symbol n_m . This is performed by a rotation of $\frac{2\pi}{n}$ and translation of $\frac{m}{n}$ times the translation vector parallel to the rotation axis.

Glide planes

The operation in a glide plane involves a translation $\frac{t}{2}$ parallel to a reflection plane followed by reflection across the plane. t denotes the distance between the successive atoms a_1 and a_3 . Figure shows the glide plane and the ordinary glide plane.

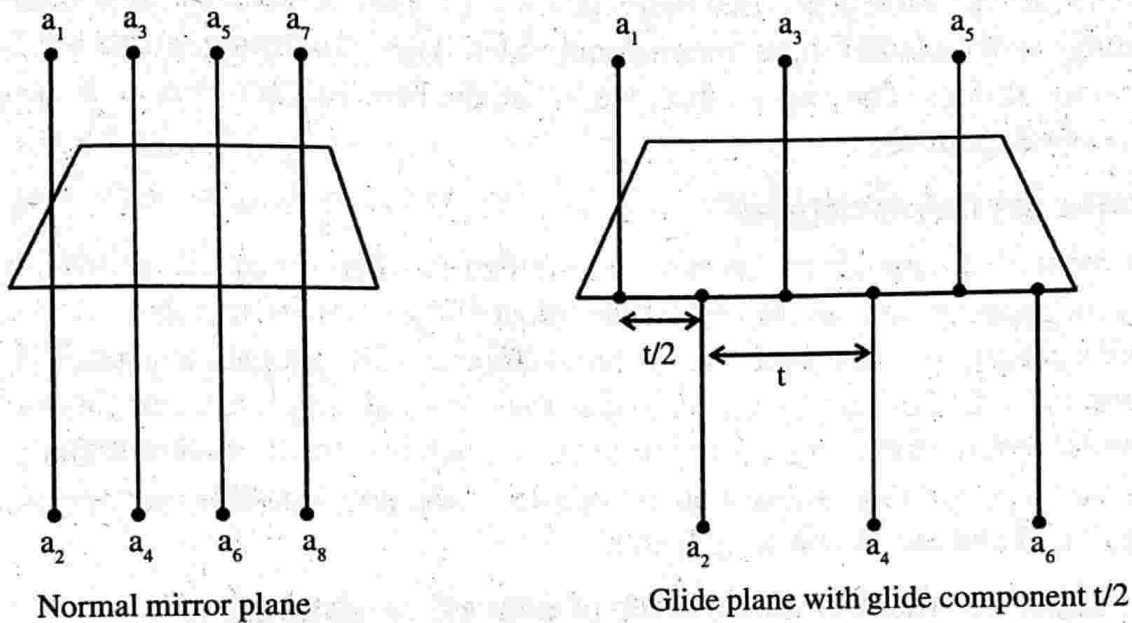

Figure 2.19

Glide planes are divided into three types. They are (i) axial glides (ii) diagonal glides and (iii) diamond glides.

Axial glides are planes whose glide component is parallel to a crystallographic axis a or b or c and equal in length to $\frac{a}{2}$ or $\frac{b}{2}$ or $\frac{c}{2}$. These are symbolised as a glide or b glide or c glide. Diagonal glides have the notation n and they correspond to planes with the vector sum of any two of the vectors $\frac{a}{2}, \frac{b}{2}, \frac{c}{2}$ as the glide component. Diamond glide occurs in the structure of diamond and is denoted by d . This plane has the glide component equal to the vector sum of any two of the following

$$\frac{a}{4}, \frac{b}{4}, \frac{c}{4}$$

Space groups

When we combine rotation symmetries of the point groups with the translational

symmetry, we obtain a space group symmetry. In this manner one generates large number of space groups, 72 to be exact. In addition to point groups plus translational groups some more combined operations such as screw axis and glide planes come in to picture. Thus one obtains 230 different space groups.

The Bravais space lattices

The internal symmetry of a crystal depends on the arrangement in the space lattice. Bravais has established that there are only 14 ways in which similar points can be arranged in a regular three dimensional order. These 14 arrangements are known as Bravais lattices. They are sc, bcc, fcc, st, bt, so, bco, eco, fco, sm, ecm, st, sr and sh already explained.

Metallic crystal structures

In most of the metals the atoms are arranged in some repeatable pattern indefinitely in space. i.e., metals are crystalline. Most of the common metals exhibit simple crystal structure such as cubic, face centred cubic and hexagonal close packed. Here our aim is to see how atoms are packed in these crystal structures. For this we have to familiar with certain crystal structure terms such as coordination number of second nearest neighbours, nearest neighbour distance, atomic radius number of atoms per unit cell and atomic packing factor.

Coordination number or number of nearest neighbours (N)

It is defined as the number of equidistant neighbour that an atom has in the given structure. It is denoted by N.

Greater the coordination number, the more closely packed up will be the structure.

For SC structure, $N = 6$

For BCC structure, $N = 8$

For FCC structure, $N = 12$

Nearest neighbour distance

The distance between the centres of two nearest neighbouring atoms is called nearest neighbour distance. If r is the radius of the atom, the nearest neighbour distance is $2r$.

For SC structure, $2r = a$

For BCC structure, $2r = \frac{\sqrt{3}}{2} a$

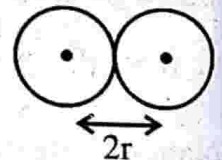

Figure 2.20

For FCC structure, $2r = \frac{a}{\sqrt{2}}$

Number of second nearest neighbours

It is the number of equidistant atoms nearest to first nearest number.

There are 12 second nearest neighbours at distance $\sqrt{2}a$ for SC. There are 6 second nearest neighbours at distance a in BCC. There are 6 second nearest neighbours at distance a in FCC structures.

Atomic radius (r)

It is defined as half the distance between nearest neighbours in a crystal without impurity.

For SC, $r = \frac{a}{2}$, for BCC, $r = \frac{\sqrt{3}}{4}a$ and for FCC, $r = \frac{a}{2\sqrt{2}}$

Number of atoms per unit cell

The number of effective lattice points (atoms) per unit cell is given by

$$n_{\text{eff}} = n_i + \frac{n_f}{2} + \frac{n_c}{8}$$

where n_i is the number of lattice points (atoms) completely inside the cell and n_f and n_c represent the lattice points occupying face centre and corner positions of the cell respectively.

For SC structure:

$$n_i = 0, n_f = 0 \text{ and } n_c = 8$$

$$\therefore n_{\text{eff}} = 1 \times 0 + \frac{1}{2} \times 0 + \frac{1}{8} \times 8 = 1$$

For BCC structure:

$$n_i = 1, n_f = 0 \text{ and } n_c = 8$$

$$\therefore n_{\text{eff}} = 1 \times 1 + \frac{1}{2} \times 0 + \frac{1}{8} \times 8 = 2$$

For FCC structure:

$$n_i = 0, n_f = 6 \text{ and } n_c = 8$$

$$\therefore n_{\text{eff}} = 1 \times 0 + \frac{1}{2} \times 6 + \frac{1}{8} \times 8 = 4$$

Atomic packing fraction (APF)

The packing of atoms in a unit cell of the crystal structure of a material is represented by atomic packing fraction (APF).

It is defined as the ratio of volume occupied by the atoms in a unit cell to that of the unit cell.

$$\text{i.e., APF} = \frac{\text{Volume of the atoms per unit cell}}{\text{Volume of the unit cell}}$$

$$= \frac{n_{\text{eff}} \times \text{Volume of each atom}}{\text{Volume of the unit cell}}$$

$$\text{APF} = \frac{v}{V}$$

Packing factor of simple cubic crystal structure

The simple cubic crystal structure of unit cell consists of atoms located at the corners only (each atom at each corner) and these atoms touch each other along the cube edges. Thus in sc structures we have

$$\text{lattice constant, } a = 2r$$

In sc each atom is surrounded by six equidistant nearest neighbours and hence the coordination number is 6.

Moreover each corner atom is shared by eight unit cells. Hence the share of each corner atom to a unit cell is one-eighth of an atom.

$$\therefore \text{The total number of atoms in effect in one unit cell} = \frac{1}{8} \times 8 = 1$$

In other words the effective number of lattice points in a simple cubic cell is one. Thus sc is a primitive cell.

$$\therefore \text{Volume of all the atoms in a unit cell } v = 1 \times \frac{4}{3} \pi r^3$$

$$\text{Volume of the unit cell, } V = a^3 = (2r)^3$$

$$\therefore \text{The packing factor, } P.F = \frac{v}{V} = \frac{4\pi r^3}{3(2r)^3}$$

i.e., $P \cdot F = \frac{\pi}{6} = 0.52$ or 52%.

Since only half the space of unit cell is filled with atoms, we can say that sc structure is loosely packed structure.

Only one element polonium at a certain temperature exhibits this structure.

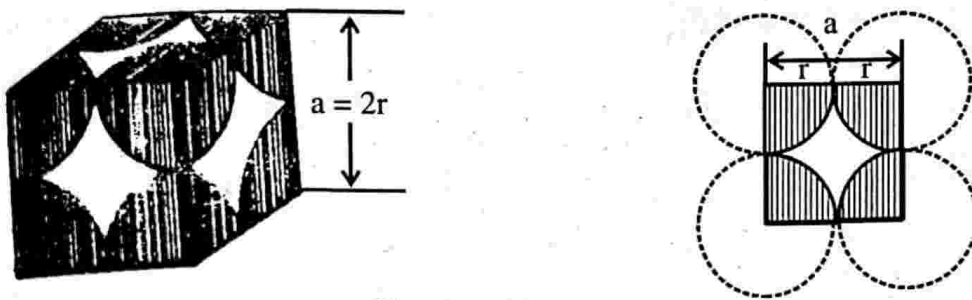

Simple cubic structure

Figure 2.21

Packing factor of body centred cubic structure

In this structure of unit cell there are 8 atoms at the corners and another atom at the body centre. The atoms at the corners do not touch each other but the corner atom touches the body centre along the body diagonal. Hence the coordination number is 8.

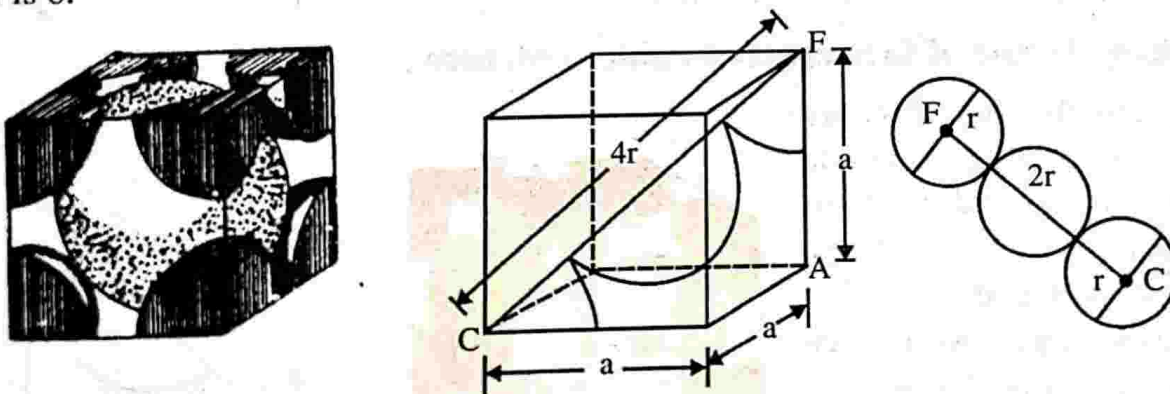

Figure 2.22: Body centred cubic structure

The number of atoms in the unit cell $= 8 \times \frac{1}{8} + 1 = 2$

\therefore Volume of the atoms in the unit cell $v = 2 \times \frac{4}{3} \pi r^3$

Volume of the unit cell, $V = a^3$

$$\therefore \text{Packing factor, } P \cdot F = \frac{v}{V} = \frac{8\pi r^3}{3a^3} \dots (1)$$

From the figure, we have

$$(AC)^2 = a^2 + a^2 = 2a^2$$

$$(FC)^2 = (AC)^2 + (AF)^2$$

$$(FC)^2 = 2a^2 + a^2 = 3a^2$$

$$(4r)^2 = 3a^2$$

$$r = \frac{\sqrt{3}}{4} a$$

Put this in eqn (1), we get

$$P \cdot F = \frac{8\pi}{3} \left(\frac{\sqrt{3}}{4} a \right)^3 = \frac{\sqrt{3}\pi}{8} = 0.68 = 68\%$$

Li, Na, K and Cr exhibit this structure.

Packing factor of face centred cubic structure

In this structure there are eight atoms at eight corners of the unit cell and six atoms at the centres of six faces. The atoms touch each other along the face diagonal. Each corner atom is shared by 8 surrounding unit cells and each of face centred atom is shared by 2 surrounding unit cells.

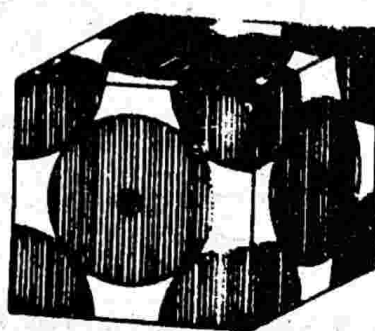

(a)

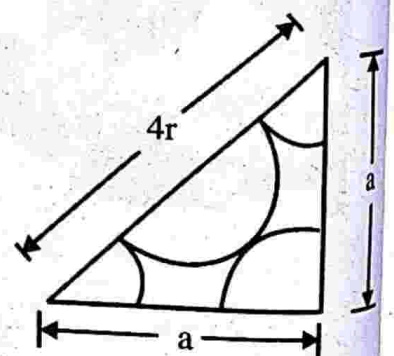

(b)

Figure 2.23: Face centred cubic structure

\therefore The total number of atoms in the unit cell

$$= 8 \times \frac{1}{8} + 6 \times \frac{1}{2} = 4$$

Volume of all atoms in the unit cell, $v = 4 \times \frac{4}{3} \pi r^3$

Volume of the unit cell, $V = a^3$

\therefore The packing factor, $P \cdot F = \frac{v}{V}$

i.e.,
$$P \cdot F = \frac{16\pi r^3}{3 \times a^3} \quad \dots (1)$$

From the figure we have

$$(4r)^2 = a^2 + a^2 = 2a^2$$

or
$$r = \frac{a}{2\sqrt{2}}$$

Put this in eqn (1), we get

$$P \cdot F = \frac{16\pi \times a^3}{3a^3(2\sqrt{2})^3} = \frac{\pi}{3\sqrt{2}} = 0.74$$

Copper, aluminium, lead and silver exhibit this structure. This is a close packed structure.

Note: The coordination number of each atom in fcc is 12. When the coordination number of an atom is less than 12, we call it as a loose packed structure.

Packing factor of hexagonal close packed structures (hcp)

The very name hexagonal indicates that hcp structure has the shape of hexagon. The unit cell of this contains one atom at each corner, one atom each at the centre of the hexagonal faces and three more atoms within the body of the cell. The atoms touch each other along the edge of the hexagon. Thus $a = 2r$.

The top layer of the hexagon contains seven atoms. Each corner atom is shared by 6 surrounding hexagonal cells and the centre atom is shared by 2 surrounding cells. The three atoms within the body of the cell are fully contributing to the cell.

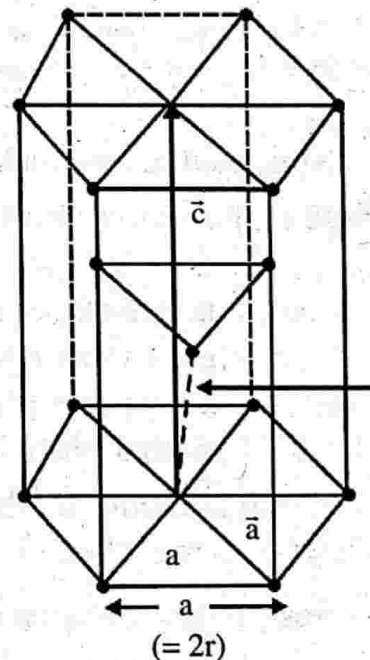

Figure 2.24: Hexagonal close packed structure

Thus the total number of atoms in the unit cell

$$= 6 \times \frac{1}{6} + 6 \times \frac{1}{6} + 1 \times \frac{1}{2} + 1 + \frac{1}{2} + 3 = 6$$

$$\therefore \text{Volume of atoms in the unit cell, } v = 6 \times \frac{4}{3} \pi r^3$$

$$v = \frac{24}{3} \pi \left(\frac{a}{2}\right)^3 = \pi a^3$$

$$\text{Volume of the unit cell (hexagon), } V = \frac{3\sqrt{3}}{2} a^2 c$$

(where c be the height of the unit cell and a be its edge).

$$\therefore \text{Packing factor, } PF = \frac{v}{V} = \frac{\pi a^3}{\frac{3\sqrt{3}}{2} a^2 c} = \frac{2\pi}{3\sqrt{3}} \left(\frac{a}{c}\right)$$

$$\frac{a}{c} \text{ can be evaluated to be } \sqrt{\frac{3}{8}}$$

$$\therefore P.F = \frac{2\pi}{3\sqrt{3}} \frac{\sqrt{3}}{\sqrt{8}} = \frac{\pi}{3\sqrt{2}} = 0.74 \text{ or } 74\%$$

Magnesium, zinc and cadmium exhibit this structure.

Note : (i) In these structures the coordination number is 12. i.e., each atom is surrounded by 12 similar and equal sized neighbours. Out of these 12 neighbours, six lie in one plane, three in an adjacent parallel plane above this plane and three in a similar plane below it.

(ii) Volume of the hexagon = base area \times height = base area \times c

$$\text{Base area} = 6 \times \text{Area of } \triangle AOB.$$

$$= 6 \times \frac{1}{2} AO \times Bd$$

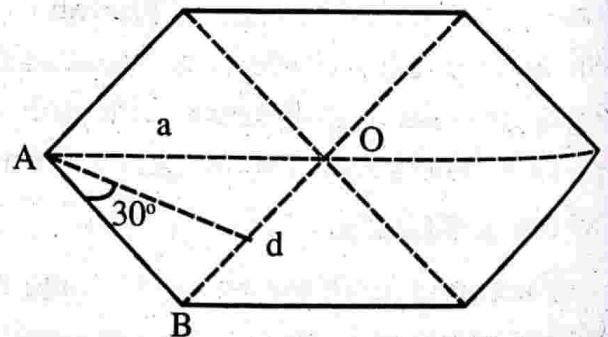

Figure 2.25

$$\text{But } \frac{Ad}{AB} = \cos 30^\circ \therefore Ad = AB \cos 30 = a \frac{\sqrt{3}}{2}$$

$$\text{Base area} = 6 \times \frac{1}{2} \times a \times a \frac{\sqrt{3}}{2} = \frac{3\sqrt{3}}{2} a^2$$

$$\therefore \text{Volume of the hexagon} = \frac{3\sqrt{3}}{2} a^2 c.$$

To evaluate $\frac{a}{c}$

The three body atoms lie in a horizontal plane at $\frac{c}{2}$ from the orthocentres of alternate equilateral triangles.

From the figure

$$AZ^2 = AX^2 + ZX^2$$

$$a^2 = \left(\frac{2}{3} \times \text{median} \right)^2 + \frac{c^2}{4}$$

$$a^2 = \frac{a^2}{3} + \frac{c^2}{4}, \quad a^2 - \frac{a^2}{3} = \frac{c^2}{4}$$

$$\frac{2}{3} a^2 = \frac{c^2}{4}, \quad \frac{a^2}{c^2} = \frac{3}{8}$$

$$\therefore \frac{a}{c} = \sqrt{\frac{3}{8}}$$

Sodium chloride (NaCl) structure

The Bravais lattice of sodium chloride structure is face centred cubic. The basis consists of one Na^+ ion and one Cl^- separated by one half the body diagonal of the unit cube. A unit cell of NaCl comprises four molecules. In this structure each ion is surrounded by six neighbours of the

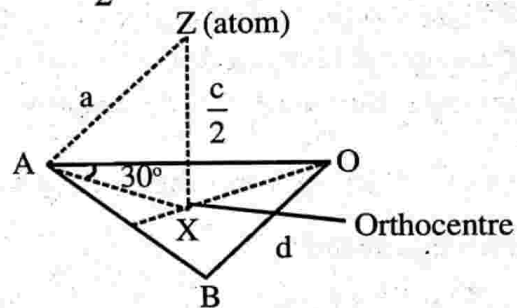

Figure 2.26

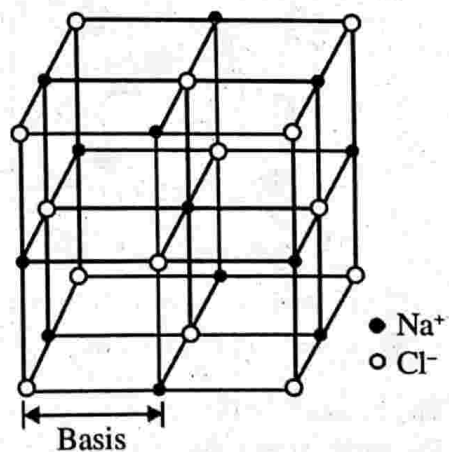

Figure 2.27: Unit cell of sodium chloride structure

opposite kind. Therefore the coordination number is six. The various positions of ions in the unit cell are as follows.

$$\text{Cl}^- : 000, \frac{1}{2} \frac{1}{2} 0, \frac{1}{2} 0 \frac{1}{2}, 0 \frac{1}{2} \frac{1}{2}$$

$$\text{Na}^+ : \frac{1}{2} \frac{1}{2} \frac{1}{2}, 00 \frac{1}{2} 0 \frac{1}{2} 0, \frac{1}{2} 00$$

Diamond structure

Diamond exhibits both cubic and hexagonal type structures. The diamond cubic (dc) structure is more common and is described here. The Bravais lattice of the diamond cubic structure is fcc with basis consisting of two carbon atoms, one located at the lattice point and other at a distance of one quarter of the body diagonal from the lattice point along the body diagonal. The unit cell of dc structure is shown in figure below. The carbon atoms placed along the body diagonals, in fact, occupy the alternate tetrahedral void positions in the fcc arrangements of carbon atoms. The packing factor of the dc structure is only 34%. The coordination number of each carbon atom is 4 and the nearest neighbour distance is equal to $\sqrt{3} \frac{a}{4}$, where a is the lattice parameter.

The dc structure may also be viewed as an interpenetration of two fcc sub lattices with their origins at $(0, 0, 0)$ and $(\frac{1}{4}, \frac{1}{4}, \frac{1}{4})$. A plane view of the positions of all the carbon atoms in the unit cell is shown below. The fractional heights of the carbon

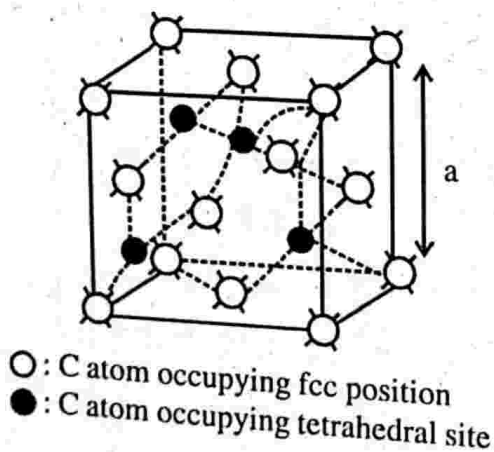

The unit cell of dc structure. The lattice is fcc with carbon atoms located at fcc positions and at alternate tetrahedral sites.

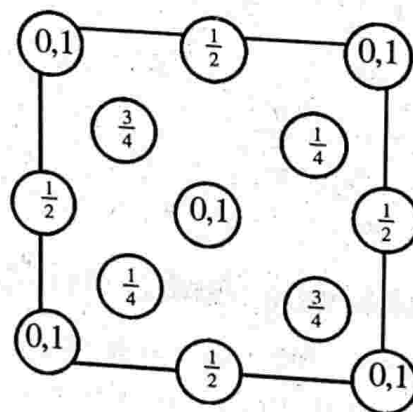

Plan view of atomic positions in dc unit cell. Numbers in the circles indicate fractional heights of the carbon atoms.

Figure 2.28

atoms relative to the base of the unit cell are given in the circles drawn at the atomic positions. Two numbers in the same circle indicate two carbon atoms at the same position located one above the other. Other materials exhibiting this type of structure are C, Si, Ge, Gats, Gray tin etc.

Note :

$$\text{From the figure } (XY)^2 = \left(\frac{a}{4}\right)^2 + \left(\frac{a}{4}\right)^2 = \frac{a^2}{8}$$

$$XZ^2 = (XY)^2 + (YZ)^2 = \frac{a^2}{8} + \frac{a^2}{16} = \frac{3a^2}{16}$$

$$(2r)^2 = \frac{3a^2}{16}$$

or $2r = \frac{\sqrt{3} a}{4}$.

$$\therefore \text{Packing factor, } \frac{v}{V} = \frac{8 \times \frac{4}{3} \pi r^3}{a^3} = \frac{\pi \sqrt{3}}{16} = 0.34 \text{ or } 34\%.$$

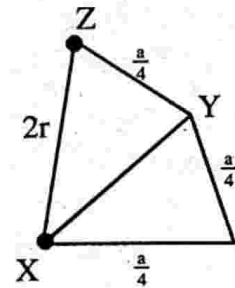

Figure 2.29

Zinc sulphide or zinc blende structure

The zinc blende structure is similar to the dc structure except that the two fcc lattices in it are occupied by different atoms and displaced from each other by one quarter of the body diagonal.

The cubic zinc sulphide structure results when zinc atoms are placed on one fcc lattice and 3 atoms on the other fcc lattice as shown. The structure is cubic. There are 4 molecules per unit cell. For each atom, there are four equally distant atoms of opposite kind arranged at regular tetrahedron. CuCl, Insb, CdS etc. exhibit this structure.

The coordinates of Zn atoms are 000,

$$0 \frac{1}{2} \frac{1}{2}, \frac{1}{2} 0 \frac{1}{2}, \frac{1}{2} \frac{1}{2} 0 \text{ and the coordinates}$$

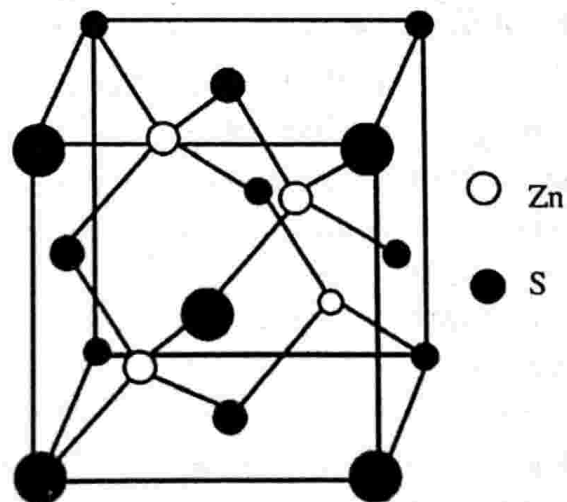

Figure 2.30: Zinc blende structure

of the 3 atoms are $\frac{1}{4} \frac{1}{4} \frac{1}{4}$, $\frac{1}{4} \frac{3}{4} \frac{3}{4}$, $\frac{3}{4} \frac{1}{4} \frac{3}{4}$, $\frac{3}{4} \frac{3}{4} \frac{1}{4}$.

Caesium chloride (CsCl) structure

The Bravais of CsCl is structure is simple cubic. The basis consists of one Cs^+ ion and one Cl^- ion. There is one molecule per primitive cell, with atoms at the corners 000 and body centred positions

at the corners $\frac{1}{2} \frac{1}{2} \frac{1}{2}$ of the simple cubic space

lattice. Each ion is at the centre of a cube of ions of the opposite kind, so that the coordination number is 8 obviously, the lattice points of CsCl are two interpenetrating simple cubic lattices, the corner of

one sub lattice is the body centre of the other. One sub lattice is occupied by Cs^+ ions and the other by Cl^- ions CsCl, NH_4Cl , RbCl, TlBr are some materials crystallising in this structure. CsCl structure is shown in figure 2.31.

Finally we give a table of cell properties dc, sc, bcc, fcc and hcp structures

Directions, planes and Miller indices

In a crystal there are large number of atoms situated at the lattice points in different directions and planes. For the study of crystal analysis we have to specify the directions and planes of lattices.

Lattice directions

The direction of line in a lattice is defined by assigning certain indices to this line. For this imagine that the line passes through the origin of the crystallographic axes. Take the coordinate axes of any point on the line. These coordinates are simplified to get a set of the smallest possible integer which when enclosed in a square bracket represents the direction of the lattice.

For example, to determine the lattice direction OQ in a cubic crystal. Take the point

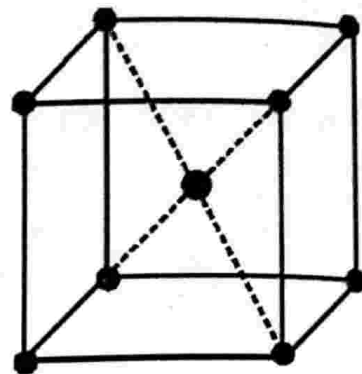

Figure 2.31: Caesium chloride structure

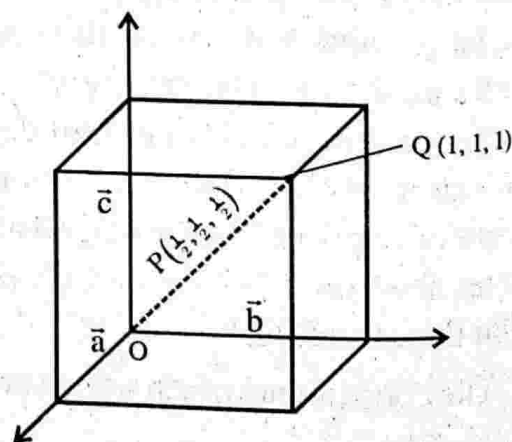

Figure 2.32

Table 2.3 : Cell properties of some crystal structures

Sl. No.	Properties	Diamond cube (dc)	Simple cube (sc)	Body centred cube (bcc)	Face centred cube (fcc)	Hexagonal close packed structure (hcp)
1.	Volume of unit cell	a^3	a^3	a^3	a^3	$\frac{3}{2}\sqrt{3}a^2c$
2.	Number of atoms per unit cell	8	1	2	4	6
3.	Number of atoms per unit volume	$\frac{8}{a^3}$	$\frac{1}{a^3}$	$\frac{2}{a^3}$	$\frac{4}{a^3}$	$\frac{4}{\sqrt{3}a^2c}$
4.	Number of nearest neighbours (Co-ordination number)	4	6	8	12	12
5.	Nearest neighbour distance (2r)	$\frac{a\sqrt{3}}{4}$	a	$\frac{a\sqrt{3}}{2}$	$\frac{a\sqrt{2}}{2}$	a
6.	Atomic radius	$\frac{a\sqrt{3}}{8}$	$\frac{a}{2}$	$\frac{a\sqrt{3}}{4}$	$\frac{a\sqrt{2}}{4}$	$\frac{a}{2}$
7.	Atomic packing factor	$\frac{\pi\sqrt{3}}{16} = 0.34$	$\frac{\pi}{6} = 0.52$	$\frac{\sqrt{3}\pi}{8} = 0.68$	$\frac{\sqrt{2}\pi}{6} = 0.74$	$\frac{\sqrt{2}\pi}{6} = 0.74$
8.	Examples	Germanium, Silicon and Carbon	Polonium	Sodium, Lithium and Chromium	Aluminium, Copper, Silver and Lead	Magnesium, Zinc and Cadmium

$P\left(\frac{1}{2}, \frac{1}{2}, \frac{1}{2}\right)$ or $Q(1, 1, 1)$ on this line, either of these points yields the direction as $[1, 1, 1]$.

Remember that any line parallel to $[1, 1, 1]$ lattice direction is represented by $[1, 1, 1]$ since parallel shifting does not change its direction.

It may be noted that the index corresponding to a direction perpendicular to the axis is zero.

It may also be noted that any direction opposite to the direction of crystallographic axis is taken as negative which are putting bars over indices. See the figure below for various examples.

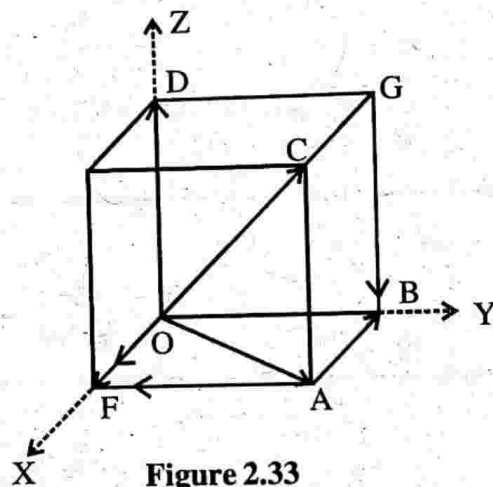

$$\vec{OA} = [1, 1, 0]$$

$$\vec{OB} = [0, 1, 0]$$

$$\vec{OC} = [1, 1, 1]$$

$$\vec{OD} = [0, 0, 1]$$

$$\vec{OF} = [1, 0, 0]$$

Figure 2.33

$$\vec{GD} = -(\vec{OB}) = -[0, 1, 0] = [0, \bar{1}, 0]$$

$$\vec{GB} = -(\vec{OD}) = -[0, 0, 1] = [0, 0, \bar{1}]$$

In the figure (33), we have

$$\vec{OA} = [1, 0, 0]$$

$$\vec{OB} = [0, 0, \bar{1}]$$

$$\vec{CE} = [1, 0, 0]$$

$$\vec{FG} = -(\vec{CE}) = -[1, 0, 0] = [\bar{1}, 0, 0]$$

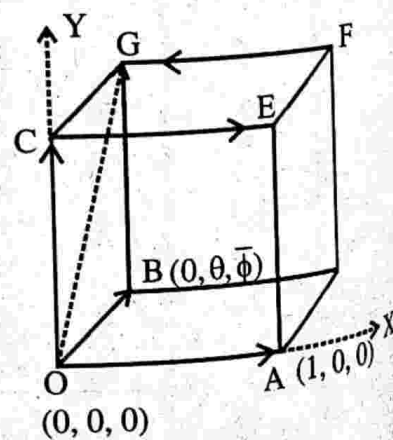

Figure 2.34

$$\vec{OG} = [0, 1, \bar{1}]$$

$$\vec{AB} = [\bar{1}, 0, \bar{1}]$$

Planes and Miller indices

All crystals are considered to be made up of a set of parallel equidistant planes passing through the lattice points. These planes are known as lattice planes. These lattice planes can be chosen in different ways as shown in figure below.

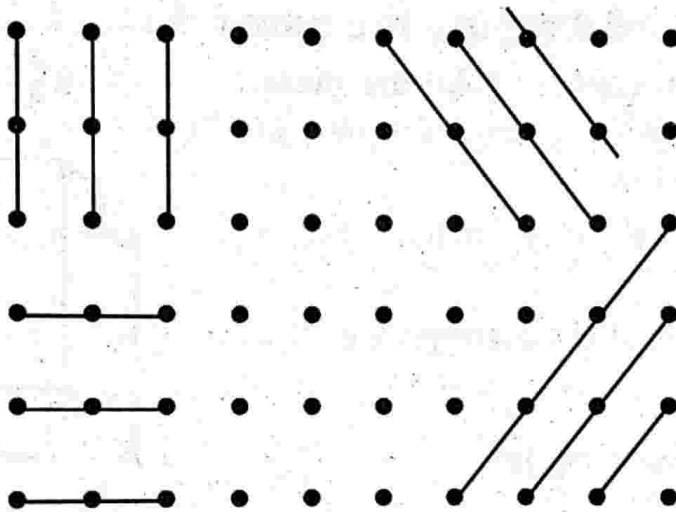

Figure 2.35

The scheme to represent the orientation of planes in a lattice was first introduced by Miller, a British crystallographer.

Miller evolved a method to designate a set of parallel planes in a crystal by three numbers (hkl) known as Miller indices.

Miller indices may be defined as the reciprocals of the intercepts made by the plane on the crystallographic axes when reduced to smallest numbers.

Following are the steps involved in the determination of Miller indices of a plane.

- (i) Find the intercepts of the plane on the crystallographic axes.
- (ii) Take reciprocals of these intercepts.
- (iii) Simplify to remove fractions, if any, and enclose the numbers obtained into paranthesis ().

In step (i), the intercepts are taken in terms of the lengths of fundamental vectors choosing one of the lattice points as the origin. If a plane is parallel to a certain axis, its intercept with that axis is taken as infinity. In step (ii) the reciprocals are taken in order to avoid the occurrence of infinity in the Miller indices

Important features of Miller indices of crystal planes

- (i) All the parallel equidistant planes have the same Miller indices. Thus the Miller indices define a set of parallel planes.
- (ii) A plane parallel to one of the coordinate axes has an intercept at infinity.
- (iii) If the Miller indices of two planes have the same ratio. i.e., (3, 1, 1) and (6, 2, 2), then the planes are parallel to each other.
- (iv) If (h, k, l) are the Miller indices of a plane, then the plane cuts the axes into h, k and l equal segments respectively.

Important planes and directions in a cubic crystal

Consider a cubic crystal. Take the plane ABCD (shaded) of the cubic crystal shown in figure 2.36 shown below.

The plane cuts the x-axis at infinity, y-axis at 1, z-axis at ∞ .

\therefore The coordinates of the intercepts are

$$\infty, 1, \infty$$

Taking the reciprocal, we get

$$\frac{1}{\infty}, 1, \frac{1}{\infty}$$

or $0, 1, 0$

Hence (0 1 0) are the Miller indices of the plane ABCD.

Also see that the direction \vec{OC} is given by [0 1 0].

i.e., the plane (0 1 0) is perpendicular to the direction [0 1 0].

The cube faces of a cubic crystal are (1 0 0), (0 1 0), (0 0 1), ($\bar{1}$ 0 0) (0 $\bar{1}$ 0) and (0 0 $\bar{1}$).

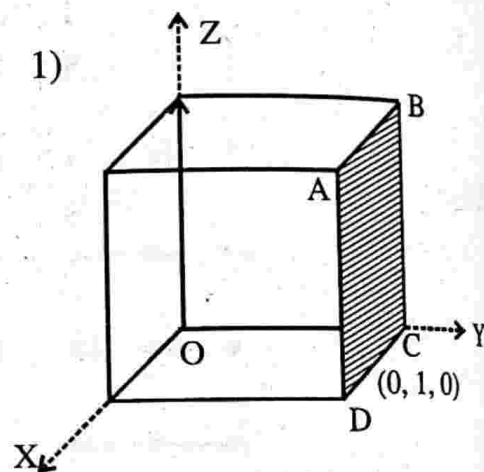

Figure 2.36

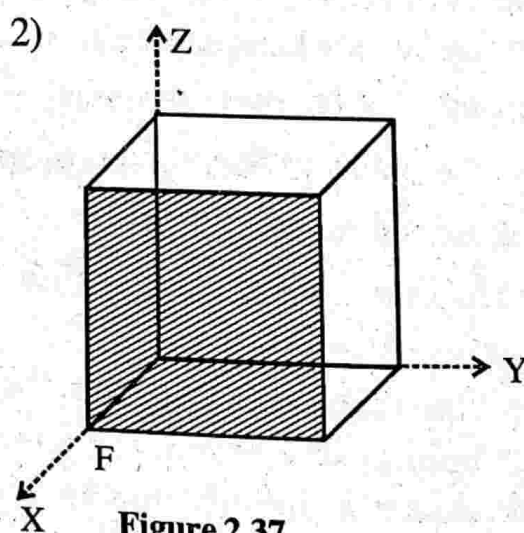

Figure 2.37

Intercepts = $1, \infty, \infty$

Reciprocals = $1, \frac{1}{\infty}, \frac{1}{\infty}$

Miller indices = (1 0 0)

The direction \vec{OF} is $[1\ 0\ 0]$

i.e., The plane $(1\ 0\ 0)$ is perpendicular to $[1\ 0\ 0]$ direction.

3)

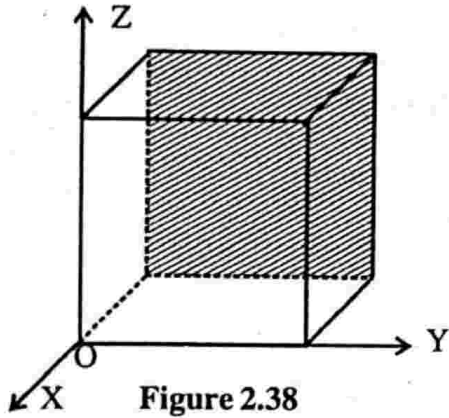

Figure 2.38

The intercepts are $-1, \infty, \infty$

Reciprocals are $\bar{1}, 0, 0$

Miller indices are $(\bar{1}\ 0\ 0)$

Note : If a plane cuts an axis on the negative axis the corresponding index is negative.

4)

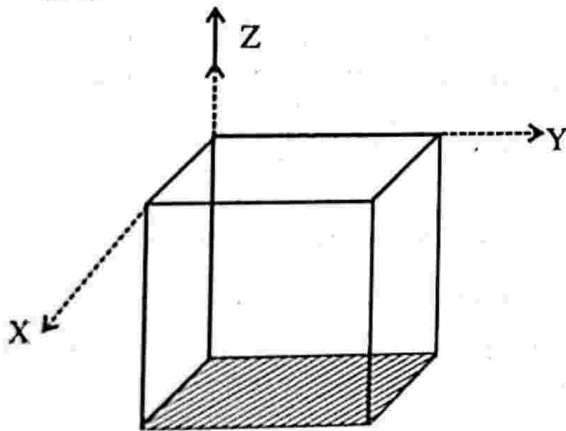

Figure 2.39

The intercepts are $\infty, \infty, -1$

Reciprocals are $0\ 0\ \bar{1}$

Miller indices are $(0\ 0\ \bar{1})$

5)

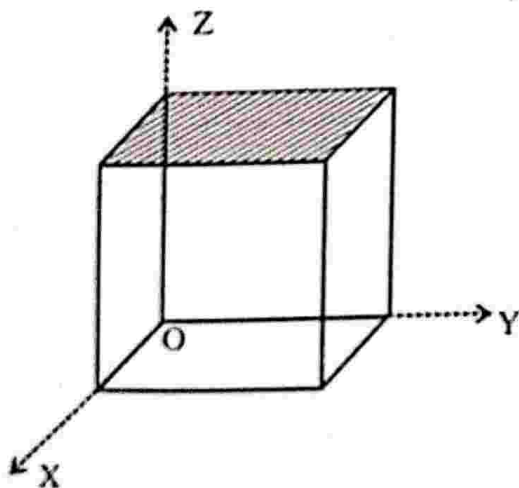

Figure 2.40

The intercepts are $\infty, \infty, 1$

Reciprocals are $0, 0, 1$

Miller indices are $(0\ 0\ 1)$

Direction \vec{OD} is $[0\ 0\ 1]$

i.e., The plane $(0\ 0\ 1)$ is perpendicular to the direction $[0\ 0\ 1]$.

6)

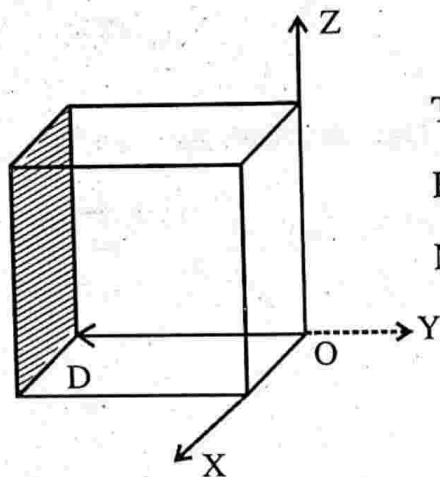

The intercepts are $\infty, -1, \infty$

Reciprocals are $0, \bar{1}, 0$

Miller indices are $(0\ \bar{1}\ 0)$

Figure 2.41

The direction \vec{OD} is $[0\ \bar{1}\ 0]$.

i.e., The plane $(0\ \bar{1}\ 0)$ is perpendicular to the direction.

Note : In cubic crystals direction $[h\ k\ l]$ is perpendicular to the plane $(h\ k\ l)$. But in general it is not so.

Distribution of atoms in the atomic planes of a simple cubic crystal

Consider the $(0, 1, 0)$ plane of a simple cubic crystal. See figure 2.35.

Let a be the lattice constant in millimetre and r be the radius of the atom in millimetre.

$a^2\ \text{mm}^2$ contains 1 atom.

$\therefore 1\ \text{mm}^2$ contains $\frac{1}{a^2}$ atoms

But we know that $a = 2r$ (see figure 2.21)

Thus we can say that $1\ \text{mm}^2$ contains $\frac{1}{4r^2}$ atoms. i.e., atoms per $\text{mm}^2 = \frac{1}{4r^2}$

For the plane (110) .

See the (110) plane shown below.

Here one side of the plane = a

The otherside of the plane = $\sqrt{2}a$

\therefore The area of the plane = $a\sqrt{2}a = \sqrt{2}a^2$

i.e., $\sqrt{2}a^2 \text{mm}^2$ contains one atom

$$\therefore 1 \text{mm}^2 \text{ contains } \frac{1}{\sqrt{2}a^2} \text{ atoms}$$

$$\text{Thus } 1 \text{mm}^2 \text{ contains } \frac{1}{4\sqrt{2}r^2} \text{ atoms}$$

$$(\because a = 2r)$$

$$\therefore \text{Atoms per mm}^2 = \frac{1}{4\sqrt{2}r^2}$$

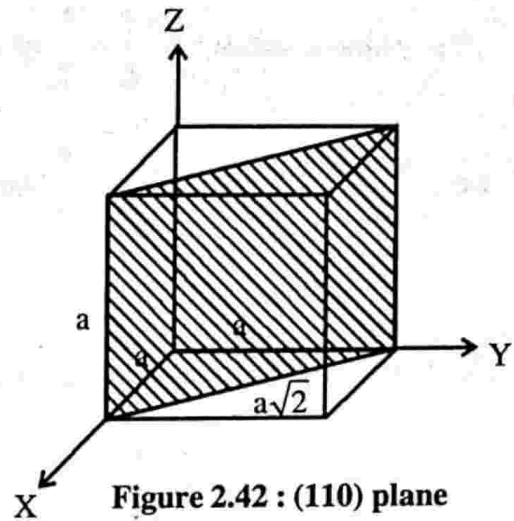

Figure 2.42 : (110) plane

For the plane (111)

See the (111) plane shown in figure below. The base of the triangle = $\sqrt{2}a$

$$\text{Altitude of the triangle} = \sqrt{\frac{3}{2}} a$$

$$\therefore \text{Area of the plane} = \frac{1}{2} b \cdot h$$

$$= \frac{1}{2} \sqrt{2} a \cdot \frac{\sqrt{3}}{\sqrt{2}} a = \frac{\sqrt{3}a^2}{2}$$

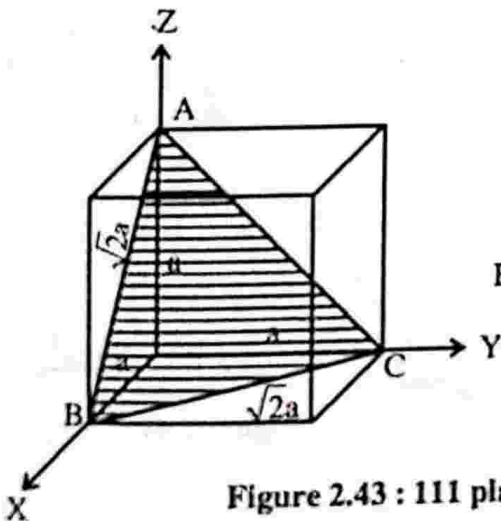
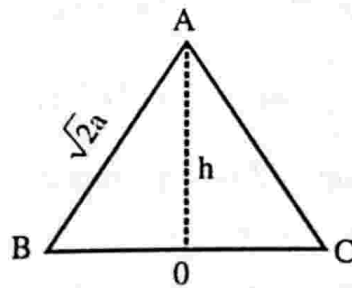

Figure 2.43 : 111 plane



$$BC = \sqrt{2}a$$

$$BO = \frac{\sqrt{2}a}{2} = \frac{a}{\sqrt{2}}$$

$$h^2 = AB^2 - BO^2$$

$$h^2 = (\sqrt{2}a)^2 - \left(\frac{a}{\sqrt{2}}\right)^2 = 2a^2 - \frac{a^2}{2} = \frac{3}{2}a^2$$

$$h = \sqrt{\frac{3}{2}} a$$

This plane contains $= \frac{3}{6} = \frac{1}{2}$ atoms

i.e., $\frac{\sqrt{3}}{2} a^2 \text{ mm}^2$ contains $\frac{1}{2}$ atoms

$\therefore 1 \text{ mm}^2$ contains $\frac{\frac{1}{2}}{\frac{\sqrt{3} a^2}{2}}$ atoms $\quad \therefore a = 2r$

We can say, 1 mm^2 contains $\frac{1}{4\sqrt{3}r^2}$ atoms

i.e., Atoms per $\text{mm}^2 = \frac{1}{4\sqrt{3}r^2}$

Similarly we can calculate atom per mm^2 for all the planes.

Separation between lattice planes in a cubic crystal

Expression for interplanar distance

Consider O as the origin and OX, OY, OZ as three rectangular cartesian axes. Let a reference plane pass through O, and consider a set of parallel planes defined by Miller indices (hkl). Beside reference through O, if next plane passes through A, B and C. Then the

respective intercepts are $\frac{a}{h}$, $\frac{b}{k}$ and $\frac{c}{l}$. If ON is the normal between this plane and the reference plane, then $ON = d$ is the interplanar spacing.

Let the normal make angles α , β , γ with crystal axes such that

$$\angle NOX = \alpha, \quad \angle NOY = \beta, \quad \text{and} \quad \angle NOZ = \gamma$$

From the figure we have

$$d = \frac{a}{h} \cos \alpha = \frac{b}{k} \cos \beta = \frac{c}{l} \cos \gamma$$

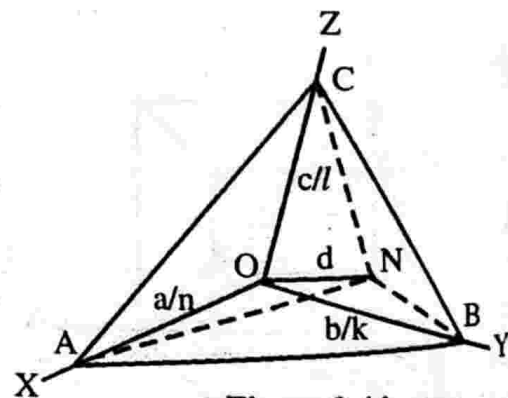

Figure 2.44

or $\cos \alpha = \frac{dh}{a}, \cos \beta = \frac{dk}{b}, \cos \gamma = \frac{dl}{c}.$

In a 3D space the direction cosines satisfy the relation.

$$\cos^2 \alpha + \cos^2 \beta + \cos^2 \gamma = 1$$

$$\therefore \left(\frac{dh}{a}\right)^2 + \left(\frac{dk}{b}\right)^2 + \left(\frac{dl}{c}\right)^2 = 1$$

$$d^2 \left(\frac{h^2}{a^2} + \frac{k^2}{b^2} + \frac{l^2}{c^2} \right) = 1$$

or $d = \left(\frac{h^2}{a^2} + \frac{k^2}{b^2} + \frac{l^2}{c^2} \right)^{-1/2}$

For a simple cubic lattice $a = b = c$

$$\therefore \text{The interplanar distance, } d = \frac{a}{(h^2 + k^2 + l^2)^{1/2}}$$

This is denoted by d_{hkl}

Thus $d_{100} = \frac{a}{(1^2 + 0^2 + 0^2)^{1/2}} = a$

$$d_{110} = \frac{a}{\sqrt{1^2 + 1^2 + 0^2}} = \frac{a}{\sqrt{2}}$$

$$d_{111} = \frac{a}{\sqrt{1^2 + 1^2 + 1^2}} = \frac{a}{\sqrt{3}}$$

Thus $d_{100} : d_{110} : d_{111} = 1 : \frac{1}{\sqrt{2}} : \frac{1}{\sqrt{3}}$

Similarly for fcc lattice

$$d_{100} = \frac{a}{2}, d_{110} = \frac{a}{2\sqrt{2}} \text{ and } d_{111} = \frac{a}{\sqrt{3}}$$

For bcc lattice $d_{110} = \frac{a}{2}$, $d_{110} = \frac{a}{\sqrt{2}}$ and $d_{111} = \frac{a}{2\sqrt{3}}$

Example 1

Calculate the interplanar spacing for a (321) plane in a simple cubic lattice whose lattice constant is 4.2×10^{-10} m.

Solution

$$a = b = c = 4.2 \times 10^{-10} \text{ m}$$

$$d_{hkl} = \frac{a}{\sqrt{h^2 + k^2 + l^2}}$$

For the plane (321), $h = 3$, $k = 2$ and $l = 1$

$$d_{321} = \frac{a}{(3^2 + 2^2 + 1^2)^{1/2}} = \frac{a}{\sqrt{14}}$$

$$d_{321} = \frac{4.2 \times 10^{-10}}{\sqrt{14}} = 1.12 \times 10^{-10} \text{ m}$$

Example 2

In a tetragonal lattice $a = b = 0.25 \text{ nm}$ and $c = 0.18 \text{ nm}$. Deduce the lattice spacing between (111) planes

Solution

$$d_{hkl} = \left(\frac{h^2}{a^2} + \frac{k^2}{b^2} + \frac{l^2}{c^2} \right)^{-1/2}$$

Here $h = 1$, $k = 1$, and $l = 1$

$$a = b = 0.25 \text{ nm} \text{ and } c = 0.18 \text{ nm}$$

$$d_{111} = \left[\frac{1}{(0.25)^2} + \frac{1}{(0.25)^2} + \frac{1}{(0.18)^2} \right]^{-1/2} \text{ nm}$$

$$d_{111} = 0.126 \text{ nm}$$

X-Ray diffraction

Introduction

X-rays are electromagnetic waves and they should exhibit the phenomenon of diffraction. However unlike visible, X-rays cannot be diffracted by devices such as ruled diffraction gratings because of their shorter wavelengths (0.1 nm order). In 1921 German physicist Max Von Laue suggested that a crystal which consisted of a 3D array of regularly spaced atoms could serve the purpose of grating. This is possible because all the atoms in a single crystal are regularly arranged with interatomic spacing of the order of a few angstroms and this is compatible with the conditions required to be satisfied for diffraction to take place.

On the suggestion of Laue, his associates, Friedrich and Knipping later successfully demonstrated the diffraction of X-rays from a thin crystal of zinc blende (ZnS). The diffraction pattern obtained on a photographic film consisted of a central spot and a series of dark spots arranged in a definite pattern around the central spot. Such a pattern is called the Laue's pattern and reflects the symmetry of the crystal. After that the phenomenon of X-ray diffraction has become an invaluable tool to determine the structure of crystals. It is also used to determine the wavelengths of X-rays.

Braggs' law

In 1912 W.H. Bragg and W.L. Bragg put forward a model which generates the conditions for diffraction in a simple way. According to their model a crystal is an aggregate of large number of parallel atomic planes. If X-rays are considered to be reflected by such a set of parallel planes followed by the constructive interference of the resulting reflected rays, the diffraction pattern is obtained. Thus the problem of diffraction of X-rays by the atoms converted into the problem of reflection of X-rays by the parallel atomic planes. Based on these considerations, Braggs derived a simple mathematical relationship which is the condition for the reflection to occur. This condition is known as the Braggs' law.

Derivation of Braggs' law

Consider a set of parallel atomic planes with interplanar spacing d . Let a parallel beam of X-rays of wavelength λ be incident on these parallel planes at a glancing angle θ such that the rays lie in the plane of the paper. Consider two such rays 1 and 2 which strike the first two planes and get partially reflected at the same angle θ . The diffraction is the consequence of constructive interference of these reflected rays. Let PL and PM be the perpendiculars drawn from the point P on the incident and reflected portions of ray 2.

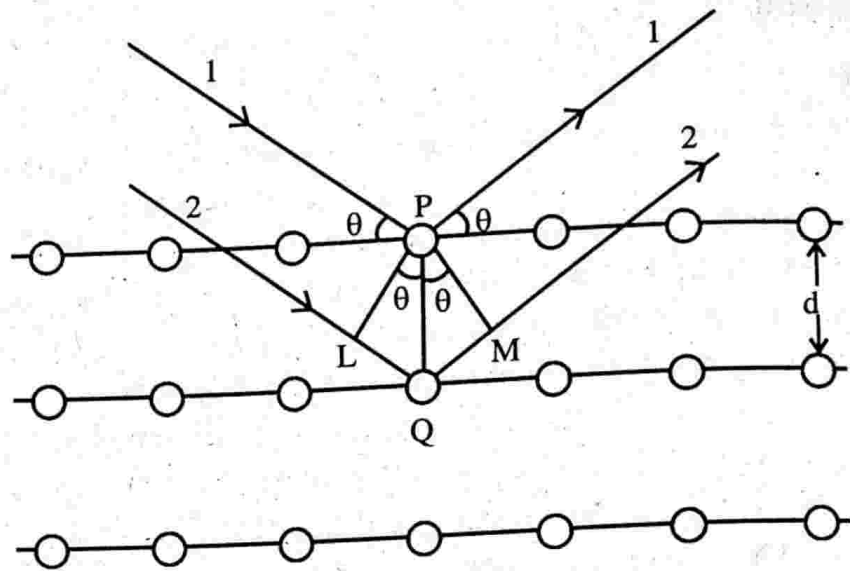

Figure 2.45: Bragg's reflection of x-rays from the atomic planes

The path difference between the rays 1 and 2
 $= LQ + QM$

From the figure we have

$$\frac{LQ}{PQ} = \sin \theta$$

or $LQ = PQ \sin \theta = d \sin \theta$

and also $QM = d \sin \theta$.

\therefore The path difference $= 2d \sin \theta$.

For constructive interference of rays, the path difference must be an integral multiple of wavelength λ .

i.e., $2d \sin \theta = n\lambda$, where n is an integer.

This equation is called Bragg's law. For $n = 0$, we get the zeroth order reflection which occurs for $\theta = 0$ i.e., in the direction of incident ray and hence cannot be observed experimentally. The diffractions corresponding to $n = 1, 2, 3, \dots$ etc. are called first, second, third etc. order diffractions.

The highest possible order is determined by the condition that $\sin \theta \leq 1$ and $\lambda \leq d$ for Bragg reflection to occur. Taking $d \approx 10^{-10}$ m, we get $\lambda \leq 10^{-10}$ m or 1\AA . X-rays having wavelengths in this range are, therefore, preferred for analysis of crystal structures.

Bragg's X-ray spectrometer

It is an apparatus devised by Bragg to verify his equation $2d \sin \theta = n\lambda$ and hence to study the crystal structure. It consists of an X-ray tube (coolidge), two slits S_1 and S_2 , a turn table and an ionisation chamber. X-rays from the X-ray tube is allowed to pass through slits S_1 and S_2 so as to obtain a narrow beam which is then allowed to fall on a single crystal (D) mounted on the turn table. The crystal is rotated by means of the turn table to change the glancing angle (θ) at which X-rays are incident at the exposed face of the crystal. The X-rays reflected from the crystal is allowed to enter into an ionisation chamber which is used for measuring the intensities of the reflected rays. Measure the glancing angles θ_1 , θ_2 and θ_3 corresponding to maximum intensities for $n = 1, 2$ and 3 - respectively. From Bragg's equation

$$2 d \sin \theta_1 = \lambda \quad \text{for } n = 1$$

$$2 d \sin \theta_2 = 2\lambda \quad \text{for } n = 2$$

$$2 d \sin \theta_3 = 3\lambda \quad \text{for } n = 3$$

Knowing the glancing angles and λ we can determine the interplanar spacings. This is repeated for different planes.

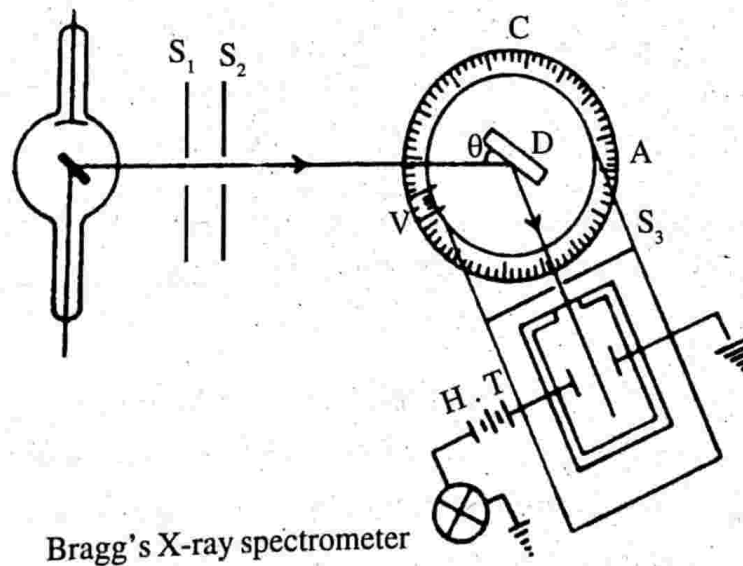

Figure 2.46

The structure of NaCl crystal was studied by using Bragg's spectrometer. The ionisation current was determined for different glancing angles. A graph was plotted between glancing angle and the ionisation current.

It was found from the graph that the first order reflection maxima occurred at 5.9° , 8.4° and 5.2° for (1 0 0), (1 1 0) and (1 1 1) planes respectively.

From Bragg's equation we have

$$2d \sin \theta = n\lambda$$

$$2d \sin \theta = \lambda \text{ for } n = 1$$

$$\text{i.e.,} \quad d \propto \frac{1}{\sin \theta}$$

$$d_{100} \propto \frac{1}{\sin 5.9} = 9.73$$

$$d_{110} \propto \frac{1}{\sin 8.4} = 6.85$$

$$d_{111} \propto \frac{1}{\sin 5.2} = 11.04$$

$$\text{or} \quad d_{100} : d_{110} : d_{111} = 9.73 : 6.85 : 11.04$$

$$= 1 : 0.74 : 1.14$$

$$\text{i.e.,} \quad d_{100} : d_{110} : d_{111} = 1 : \frac{1}{\sqrt{2}} : \frac{2}{\sqrt{3}}$$

This is nothing but the ratio of interplanar distances in fcc structure. From this Bragg concluded that sodium chloride crystal has a face centred cubic structure.

Rotating crystal method

A single crystal is held in the path of monochromatic radiations and is rotated about an axis. i.e., λ is fixed while θ varies. Different sets of parallel atomic planes are exposed to incident radiations for different values of θ and reflection takes place from those atomic planes for which d and θ satisfy the Bragg's law. This method is known as the rotating crystal method.

In this method a small and well-formed single crystal is mounted perpendicular to the beam. The single crystal having dimensions of the order of 1mm is positioned at the centre of a cylindrical holder concentric with the rotating spindle as shown in figure. A photographic film is attached at the inner circular surface of the cylinder.

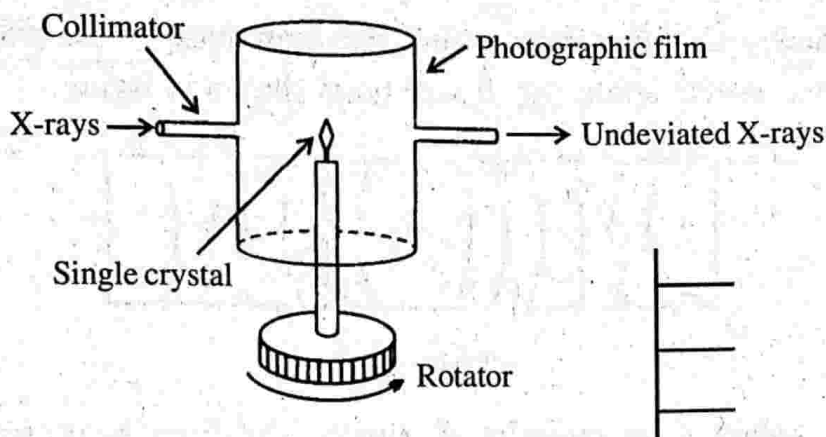

Figure 2.47

The diffraction takes place from those planes which satisfy the Bragg's law for a particular angle of rotation. When the crystal is rotated slowly successive planes pass through orientation, each producing a spot on the film. The position on the film when developed indicates the orientation of the crystal at which spot was formed. The data obtained from these spots give information about the structure of ordinary and complex molecules.

Powder crystal method

The sample in the powdered form is placed in the path of monochromatic X-rays. i.e., λ is fixed while θ and d vary. Thus a number of small crystallites with different orientations are exposed to X-rays. The reflections take place for those values of d , θ and λ which satisfy the Bragg's law. This method is called the powder method. The experimental arrangement consists of a monochromatic X-ray collimated by two slits S_1 and S_2 falls on the powdered specimen taken in a thin glass tube. The specimen S is suspended vertically on the axis of a cylindrical camera. The photographic film is mounted round the inner surface of the camera as shown in figure.

The powder specimen of the crystal can be imagined to be a collection of random oriented tiny crystals exposing all values of glancing angles to the incident beam. For a given λ and a given d , there can be only one value of θ which satisfies Bragg's law. Such reflected beams emerge out from the specimen in all directions inclined at an angle 2θ with the direction of the incident beam. The reflected rays will

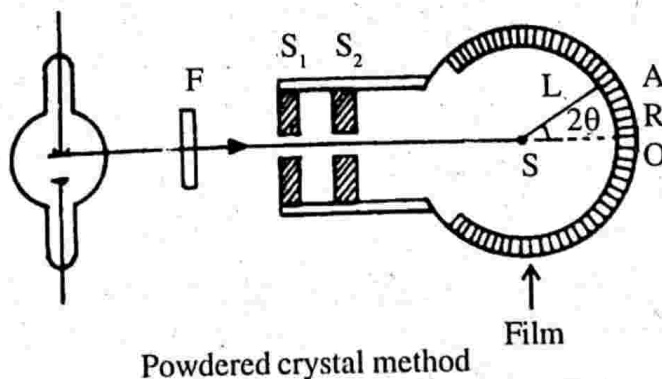

Figure 2.48

be on the surface of a cone, vertex at the specimen, base on the photographic film and having semi vertical angle 2θ . It will be as shown in figure.

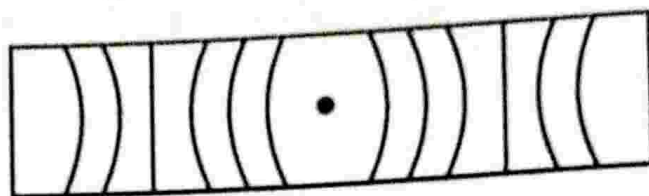

Figure 2.49

Let L be the radius of the cylindrical camera. The direct beam strikes the film at θ . Suppose a spectrum with glancing angle θ is found at A which is at a distance of R from O .

$$\text{Then } \theta = \frac{R}{2L} \left(\text{Angle} = \frac{\text{Arc}}{\text{Radius}} \right)$$

Using this value of θ in Bragg's equation and knowing the value of λ , d the interplanar distance can be calculated. This method is employed in the study of microcrystalline substances like metals, alloys, carbon, fluorescent powders and other forms where single crystals are not available.

IMPORTANT FORMULAE

1. Number of atoms per unit cell, $n_{\text{eff}} = n_i + \frac{n_f}{2} + \frac{n_c}{8}$

n_i → number of lattice points

n_f → number of lattice points occupying face centre

n_c → number of lattice points occupying corners.

2. Atoms packing fraction:

$$\text{APF} = \frac{\text{Volume of atoms per unit cell}}{\text{Volume of the unit cell}}$$

$$\text{APF} = n_{\text{eff}} \times \frac{\text{Volume of each atom}}{\text{Volume of the unit cell}}$$

3. Interplanar distance:

$$d = \left(\frac{h^2}{a^2} + \frac{k^2}{b^2} + \frac{l^2}{c^2} \right)^{-\frac{1}{2}}$$

4. Bragg's law:

$$2d \sin \theta = n\lambda \quad n = 1, 2, 3 \dots$$

5. Properties of crystal structures

Sl. No.	Crystal system (7)	Lattice parameters	Bravais lattice (14)	Examples
1	Cubic	$a = b = c, \alpha = \beta = \gamma = 90^\circ$	sc, bcc, and fcc	Ag, Cu, Fe Li, Na, K, Cr, NaCl
2	Tetragonal	$a = b \neq c, \alpha = \beta = \gamma = 90^\circ$	st, bct	β -Sn, TiO_2
3	Orthorhombic	$a \neq b \neq c, \alpha = \beta = \gamma = 90^\circ$	so, bco, eco, fco	$\text{KNO}_3, \text{BaSO}_4,$ PbCO_3
4	Monoclinic	$a \neq b \neq c, \alpha = \beta = 90^\circ \neq \gamma$	sm, ecm	$\text{CaSO}_4 \cdot 2\text{H}_2\text{O},$ $\text{FeSO}_4, \text{Na}_2\text{SO}_4$
5	Triclinic	$a \neq b \neq c, \alpha \neq \beta \neq \gamma \neq 90^\circ$	st	$\text{K}_2\text{Cr}_2\text{O}_7, \text{CuSO}_4 \cdot 5\text{H}_2\text{O}.$
6	Trigonal	$a = b = c, \alpha = \beta = \gamma \neq 90^\circ$	sr	As, Sb, Bi, Calcite
7	Hexagonal	$a = b \neq c, \alpha = \beta = 90^\circ$ $\gamma = 120^\circ$	sh	$\text{SiO}_2, \text{Zn, Mg, Cd}.$

UNIVERSITY MODEL QUESTIONS

Section A

Short answer type questions

1. What do you mean by solid?
2. What are crystalline and amorphous solids? Give examples.
3. Distinguish between crystalline and amorphous solids.
4. Define (i) a crystal (ii) lattice points and (iii) crystal lattice.
5. How would you generate a crystal structure from a space lattice and a basis?
6. What is a unit cell?
7. Define (i) crystallographic axis (ii) lattice parameters.
8. Distinguish between a primitive cell and a unit cell.
9. What is crystallography?
10. How does a crystal differ from a lattice?
11. Name the seven basic crystal systems.
12. What is a cubic crystal system? What are its Bravais lattices?
13. Draw the unit cells corresponding to sc, bcc and fcc.
14. Define a tetragonal crystal system Draw the unit cells of st and bct.
15. Define (i) point group symmetry and (ii) space group symmetry.
16. What is (i) inversion symmetry
(ii) reflection symmetry
(iii) rotation symmetry.
17. When a crystal is said to possess a rotation-inversion axis?
18. Name two translational symmetry elements.
19. What is screw axis symmetry?
20. What is glide plane symmetry?
21. What is meant by coordination number what is its significance?
22. What is atomic packing factor? What does it indicate?
23. Differentiate between loose packed and close packed structures.
24. How do we assign direction to a line in a lattice?
25. What are lattice planes?
26. What are Miller indices? What is their importance?
27. How does hcp structure differ from bcc structure?
28. Explain without calculation, why fcc and hcp structures have the same packing factor.
29. Draw the direction $[1 \bar{1} 1]$ in a cubic crystal.

30. Draw $(\bar{1} 1 1)$ plane in a cubic crystal.
31. Draw the following planes of a unit cubic crystal
(i) $(1 0 0)$ (ii) $(0 1 0)$ (iii) $(0 0 1)$
32. Draw the following planes of a unit cubic crystal
(i) $(\bar{1} 0 0)$ (ii) $(0 \bar{1} 0)$ (iii) $(0 0 \bar{1})$
33. What is the difference between the two planes $(1 0 0)$ and $(2 0 0)$.
34. Draw the $(2 0 0)$ plane of a unit cubic crystal.
35. What type of lattice and basis do the following structures have
(i) sodium chloride (ii) diamond cubic
36. Write down the various positions of Na^+ and Cl^- in the unit cell of sodium chloride crystal.
37. Write down the coordinates of Zn and S atoms in the unit cell of ZnS.
38. Diamond is the hardest substance known inspite of the fact that the packing factor and the coordination number of carbon atom in the dc structure are quite low. Explain.
39. Write down the various positions of C^{+4} and I^- in the unit cell of caesium chloride crystal.
40. Draw the unit cell of caesium chloride crystal.
41. What are the important features of Miller indices of a crystal.
42. Draw the following planes of a unit cubic crystal.
(i) (110) (ii) (111)
43. Write down an expression for the interplanar distance and explain the symbols used.
44. What is diffraction?
45. Write down Bragg's equation and explain their symbols.
46. Draw the diagram of Bragg's X-ray spectrometer.
47. What are the uses of X-ray diffraction method?
48. Explain why X-ray diffraction method is suitable for the analysis of crystal structures.
49. Why zeroth order diffraction is not considered in X-ray diffraction?
50. Why cannot ordinary optical grating diffract X-rays?

Section B

(Answer questions in about half a page to one page)

Paragraph / problem

1. Derive the packing factor of simple cubic crystal structure.
2. Derive the packing factor of body centred cubic structure.
3. Derive the packing factor of face centred cubic structure.

4. Obtain an expression for the packing fraction for hcp structure.
5. Show that the $\frac{a}{c}$ ratio for an ideal hcp lattice is $\sqrt{\frac{3}{8}}$.
6. Find the Miller indices of one diagonal planes of a unit cubic crystal (1 1 0)
7. Calculate the number of carbon atoms per unit cell of diamond.
8. Show that the packing factor of dc structure is only 34%.
9. Derive an expression for the interplanar distance.
10. Explain the rotating crystal method.
11. Explain the powder crystal method.
12. Derive Bragg's law
13. A plane makes intercepts of 1, 2 and $0.5A^\circ$ on the crystallographic axis of an orthorhombic crystal with $a:b:c = 3:2:1$. Determine the Miller indices of this plane. (312)
14. Obtain the Miller indices of a plane which intercepts $a, \frac{b}{2}, 3c$ in a simple cubic unit cell. (3 6 1)
15. The Miller indices of a plane in a simple cubic crystal are 1 2 3. Find the coordinates of the plane $\left(a \frac{b}{2} c \right)$
16. Find the Miller indices for planes with intercepts.
 - (i) $a, 2b, \infty$ (ii) $a, b, -c$ (iii) $\frac{a}{2}, b, \infty$ (2 1 0, 1 1 $\bar{1}$, 2 1 0)
17. Calculate the distance between two atoms of a basis of the diamond structure. If the lattice constant of the structure is 5 \AA . (2.17 \AA)
18. The Miller indices of a plane is (3 2 6), sketch the plane.
19. A plane makes intercepts of 1, 2 and $3A^\circ$ on the crystallographic axes of an orthorhombic crystal with $a:b:c = 3:2:1$. Determine the Miller indices of this plane (9, 3, 1)
20. The spacing between successive (100) planes in NaCl is 2.82 \AA . X-rays incident on the surface of the crystal is found to give rise to first order Bragg reflection at glancing angle 8.8° . Calculate the wavelength of X-rays. (0.863 \AA)
21. Calculate the glancing angle on the plane (110) of a cubic rock salt crystal ($a = 2.81 \text{ \AA}$) corresponding to second order diffraction maxima of wavelength 0.71 \AA . (20.934 $^\circ$)
22. The Bragg angle for the first order reflection from (111) plane in a crystal is 60° calculate the interatomic spacing if X-rays of wavelength $1.8 \times 10^{-10} \text{ m}$ are used (1.8 $\times 10^{-10} \text{ m}$)

23. If X-rays of wavelength 0.5 \AA are diffracted at an angle of 5° in the first order. What is the spacing between the adjacent planes of the crystal. At what angle will second maximum occur.
(2.87 \AA , 10.03°)
24. A metal with bcc structure shows the first (smallest angle) diffraction peak at a Bragg angle of $\theta = 30^\circ$. The wavelength of X-ray used is 2.1 \AA . Find the volume of the primitive unit cell of the metal.
(13.1 \AA^3)
25. The angle of reflection of neutron beam from a crystal of interplanar spacing 3.84 \AA is 30° . Find the speed of the neutron.
($1.03 \times 10^3 \text{ ms}^{-1}$)
26. In a tetragonal lattice $a = b = 0.25 \text{ nm}$, $c = 0.18 \text{ nm}$, deduce the spacing between (111) planes
($d = 0.126 \text{ nm}$)

Section C

(Answer questions in about one or two pages)

Long answer questions - Essays

1. Deduce Bragg's law in X-ray diffraction. Describe Bragg's spectrometer and explain how it is used to determine the wavelength of X-rays.
2. Derive Bragg's law of X-ray diffraction crystals. Give an account of powder method of crystal structure analysis.
3. Derive Bragg's law for X-ray diffraction in crystals. How it is verified. Describe and explain rotating crystal method of crystal structure analysis.

Hints to problems

1. to 12 See book work
13. Intercepts are $1 \ 2 \ \frac{1}{2}$

Intercept in terms of unit cell dimension

$$= \frac{1}{a} \frac{2}{b} \frac{1}{2c}$$

$$= \frac{1}{3} \frac{2}{2} \frac{1}{2}$$

$$= \frac{1}{3} \ 1 \ \frac{1}{2}$$

Reciprocals

$$= 3 \ 1 \ 2$$

14. Intercepts are

$$1 \ \frac{1}{2} \ 3$$

Reciprocals

$$1 \ 2 \ \frac{1}{3}$$

Miller indices

$$3 \ 6 \ 1$$

15. Miller indices 1 2 3
 Reciprocals 1 2 3

\therefore Intercepts $a, \frac{b}{2}, \frac{c}{3}$

16. Try yourself

17. Distance between two atoms in a diamond $= \frac{\sqrt{3} a}{4}$, $a = 5 \text{ \AA}$

18. The coordinates of the Miller indices (3 2 6), are $2a, 3b, c$. Thus the plane is

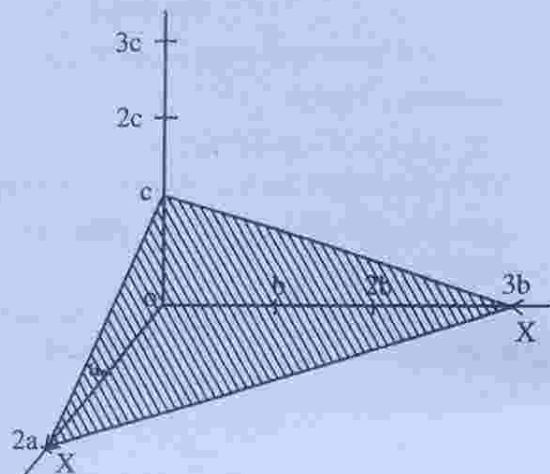

19. Same as problem No. 1

20. $2d \sin \theta = n\lambda$

$d = 2.82 \text{ \AA}$, $\theta = 8.8^\circ$, $\sin \theta = 0.153$ and $n = 1$ calculate λ .

21. Spacing for (110) plane, $d = \frac{a}{\sqrt{h^2 + k^2 + l^2}}$ $h = 1, k = 1, l = 0 \therefore d = 1.987 \text{ \AA}$

Use $2d \sin \theta = n\lambda$, $n = 2$, $\sin \theta = \frac{\lambda}{d} = \frac{0.71 \times 10^{-10}}{1.987 \times 10^{-10}} = 0.3573$

$\theta = 20.934^\circ$

22. $2d \sin \theta = n\lambda$, $\theta = 60^\circ$, $\lambda = 1.8 \times 10^{-10} \text{ m}$, $n = 1$

$\therefore d = 1.039 \times 10^{-10} \text{ m}$ gives $d_{111} = 1.039 \times 10^{-10} \text{ m}$.

$a = d_{111} \times \sqrt{3} = 1.039 \times 10^{-10} \times 1.732 = 1.8 \times 10^{-10} \text{ m}$.

For a simple cubic $d_{100} = a$ then $d_{111} = \frac{a}{\sqrt{3}}$

23. $2d \sin \theta = n\lambda$. $\lambda = 0.5 \times 10^{-10}$ m, $\theta = 5^\circ$, $\sin \theta = 0.0871$ and $n=1$ we get $d = 2.87 \text{ \AA}$.

For second order maximum

$$2d \sin \theta' = 2\lambda$$

$$\sin \theta' = \frac{\lambda}{d} = \frac{0.5 \times 10^{-10}}{2.87 \times 10^{-10}} = 0.1742$$

$$\theta' = 10.03^\circ$$

24. $2d_{hkl} \sin \theta = \lambda$

For the first peak $d_{hkl} = d_{110}$

$$d_{110} = \frac{a}{\sqrt{1^2 + 1^2}} = \frac{a}{\sqrt{2}}$$

$$\therefore a = 2.1 \times \sqrt{2} \text{ \AA}$$

Volume of the primitive cell $V = \frac{a^3}{2} = 13.1$

25. $2d \sin \theta = \lambda$. $\lambda = 2 \times 3.84 \times \sin 30 = 3.84 \text{ \AA}$

$$\lambda = \frac{h}{p} = \frac{h}{mv}. \quad m = 1.67 \times 10^{-27} \text{ kg. Find } v.$$

$$26. \quad d = \left(\frac{h^2}{a^2} + \frac{h^2}{b^2} + \frac{h^2}{c^2} \right)^{-1/2} = \left(\frac{1}{0.25^2} + \frac{1}{0.25^2} + \frac{1}{0.18^2} \right)^{-1/2}$$

$$= (16 + 16 + 30.86)^{-1/2}$$

$$d = 0.126 \text{ nm.}$$

3

▨ BASIC ELEMENTS OF SPECTROSCOPY ▨

Introduction

Spectroscopy is the study of interaction between matter and electromagnetic waves. Historically spectroscopy originated through the study of visible light dispersed according to its wavelength. e.g., by a prism. Later this concept was extended greatly to comprise any interaction with electromagnetic waves as a function of wavelength. Spectroscopic data is often represented by a spectrum. Spectrum is a plot of the response of interest as a function of wavelength.

Daily observations of colour can be related to spectroscopy. Neon light is a direct application of atomic spectroscopy. Neon and other noble gases have a characteristic emission colours. A commonly encountered molecular spectrum is that of NO_2 . NO_2 has a characteristic red absorption colours.

Atoms and molecules have unique spectra. These spectra can be interpreted to derive information about the atoms and molecules and they can also be used to detect, identify and quantify chemicals.

The quantisation of energy

According to classical physics, radiation which behaves like an oscillator (radiation originates from an oscillating charge), should have continuous energy distribution. In 1900 Max Planck made a daring assumption that the oscillators of radiation should not have a continuous distribution of possible energies, but it must have specific energies.

According to Planck an oscillator emits radiation of energy $h\nu$ when it jumps from one energy state to the next lower state. When it jumps from lower state to the next higher state it absorbs radiation of energy $h\nu$. In other words emission and absorption take place not in continuous manner as predicted by classical physics but in discrete manner, each discrete bundle carries an energy $h\nu$, where h is called Planck's constant whose value is

$$h = 6.626 \times 10^{-34} \text{ Js}$$

Each discrete bundle of energy is called as a quantum of energy. This idea of Planck later extended to cover many other forms of the energy of matter.

Here we deal with energy of molecules. A molecule may possess rotational en-

ergy, vibrational energy and electronic energy. Rotational energy is due to the rotation of molecules about its centre of gravity. Vibrational energy is due to the periodic displacement of molecule's atoms from their equilibrium positions. Since the electrons associated with atoms are in unceasing motion, we can say that molecules also possess electronic energy. The electrons occupy one of its discrete levels. These energy levels are quantised. i.e., when electrons jump from one level to another, they release or absorb finite amount of energy. This idea can be extended to molecules. A molecule can exist in a variety of rotational, vibrational energy levels. When it moves from one level to another energy involved is quantised like electronic energy. Let E_1 and E_2 be two rotational energy

levels of a molecule. The molecule can go from level E_1 to E_2 by absorbing energy $E_2 - E_1$. According to Planck, this energy difference has the form

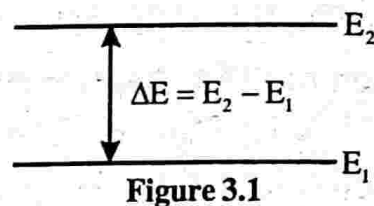

$$E_2 - E_1 = h\nu$$

where h is the Planck's constant and ν is the frequency of radiation absorbed. Similarly when the molecule jumps from level E_2 to E_1 , the excess energy is released in the form of electromagnetic radiation with energy $h\nu$

i.e.,
$$E_2 - E_1 = h\nu$$

This extension of idea of Planck to molecules was confirmed experimentally.

Suppose a molecule is in level E_1 and is irradiated with a single frequency ν , then the energy $E_2 - E_1 = h\nu$ will be absorbed from the incident beam and the molecule will jump to energy level E_2 . The radiation after interaction with the molecule is allowed to fall on a detector, will show that its intensity has decreased. If we use a beam containing several frequencies for irradiation, then the detector will show that energy has been absorbed only from that frequency $\nu = \frac{E_2 - E_1}{h}$ and all other frequencies undiminished in intensity. The spectrum so obtained is called an absorption spectrum.

If the molecule is in the energy level E_2 may jump to level E_1 by emitting radiation of energy $E_2 - E_1 = h\nu$. The detector would show that the radiation emitted has a frequency of $\nu = \frac{E_2 - E_1}{h}$. The spectrum so obtained is called an emission spectrum.

The energy differences between the rotational, vibrational and electronic energy levels are very small since $h = 6.626 \times 10^{-34}$ Js. The energy differences are measured in joules per molecule. To have an appreciable energy change we take a gram molecule of a substance. It contains 6.02×10^{23} molecules. To get the total energy change $h\nu$ has to be multiplied by 6.02×10^{23} .

Joule is not the only unit used to represent the transitions between energy states. Various other characteristics such as ν , λ of the absorbed or emitted radiation during transitions between energy states can also be used as units. Frequency ν is expressed in hertz, wavelength λ in metre and wave number in m^{-1} .

Regions of the spectrum

Spectroscopy is a sufficiently a broad field that many sub disciplines exist each with numerous implementations of specific spectroscopic techniques. Types of spectroscopy are distinguished by the type of radiative energy involved in the interaction. This type includes

1. Electromagnetic radiation. It was the first source of energy used for spectroscopic studies. Techniques that employ electromagnetic radiation are typically classified by the wavelength (frequency) region of the spectrum and include γ -ray, X-ray, u-v ray. Infrared, microwave, nuclear magnetic resonance (nmr) and electron spin resonance (e.s.r) spectroscopy.
2. Particles due to their de-broglic wavelength can also be a source of radiative energy. Both electrons and neutrons are commonly used.
3. Acoustic spectroscopy involves radiated pressure waves as the source of energy.
4. Mechanical methods can be employed to impart radiating energy similar to acoustic waves to solid materials.

Among the four types discussed above we are interested only in the first type.

Electromagnetic spectrum and the corresponding spectroscopy

The orderly distribution of electromagnetic radiations according to their wavelength or frequency is called electromagnetic spectrum. The range of the electromagnetic spectrum varies from 3×10^7 Hz to 3×10^{20} Hz (10m to 1 picometre). The whole electromagnetic spectrum has been classified into different regions in order of increasing frequency (decreasing wavelength) according to their type of excitation. The boundaries between the regions are not sharp. i.e., There is overlapping in certain regions of the spectrum. Each region of the spectrum is associated with different molecular processes. Accordingly we have six regions of spectrum.

1. Radio frequency region

This region extends from 3×10^7 Hz to 3×10^{10} Hz (10m to 1cm wavelength).

This frequency region is important to a spectroscopist in the sense that the phenomenon of nuclear magnetic resonance (n.m.r) and electron spin resonance (e.s.r) occur at this frequency region. The nuclear magnetic resonance occur at the lower part of the radio frequency region (≈ 100 MHz) and electron spin resonance occur at the upper part of the radio frequency region ($\approx 10^{10}$ Hz). Since this frequency is considerably at the end of radio frequency region we can also say that e.s.r. occurs at the long wavelength edge of the microwave region.

Nuclear magnetic resonance (n.m.r)

If we consider a nucleus as a point charge spinning about its own axis, it constitutes a circular current which in turn produces a magnetic dipole. In other words the spinning particle behaves as a tiny bar magnet placed along the spin axis. When such nucleus is subjected to an external magnetic field, it is due to interaction between two fields the spin associated with the nucleus change direction. As a result of transition of nuclear spins between energy levels, emission or absorption spectra is obtained. This phenomenon is called nuclear magnetic resonance. This occurs at a frequency of about 100MHz. The energy change involved in the change of nuclear spin is of the order of 10^{-2} joules / mole.

$$\begin{aligned} \text{We have } E &= h\nu = 6.62 \times 10^{-34} \times 100 \times 10^6 \\ &= 6.62 \times 10^{-26} \text{ J} \end{aligned}$$

$$\begin{aligned} \text{For one mole } E &= Nh\nu = 6.02 \times 10^{23} \times 6.62 \times 10^{-26} \\ &= 3.99 \times 10^{-2} \text{ joules / mole} \end{aligned}$$

Electron spin resonance (e.s.r)

Electron is a charged particle spinning about an axis constitutes a circular electric current which in turn produces a magnetic dipole. This dipole interacts with a magnetic field. As a result of interaction a transition of electron spins between energy levels occur. This gives rise to emission or absorption spectrum. This phenomenon is called electron spin resonances. This occurs at a frequency about 10^{10} Hz. The energy change involved in the change of electron spin is of the order of 10 joules / mole.

$$E = h\nu = 6.62 \times 10^{-34} \times 10^{10} = 6.62 \times 10^{-24} \text{ J}$$

$$\begin{aligned} \text{For 1 mole } E &= Nh\nu = 6.02 \times 10^{23} \times 6.62 \times 10^{-24} \\ &= 3.99 \text{ joule / mole.} \end{aligned}$$

2. Microwave region

This region extends from 3×10^{10} Hz to 3×10^{12} Hz (1cm to 100 μ m wavelength).

For a spectroscopists the microwave region is concerned with the study of rotating molecules and is called as rotational spectroscopy. The energy change involved due to rotation of molecules is of the order of 100 joules / mole. (Remember $E = Nh\nu$).

We know that dielectrics are of two types namely non-polar and polar. Polar dielectrics like water, alcohol, CO_2 , NH_3 , HCl etc. are polar molecules. In polar molecules the centre of mass of positive charges does not coincide with centre of mass of negative charges. In this each molecule has zero dipole moment.

Now we consider the pure rotation of a polar molecule. Pure rotation means centre of gravity of the molecule doesnot move. During rotation the positive and negative charges change their places periodically (see figure below). This is similar to a fluctuating electric field of radiation.

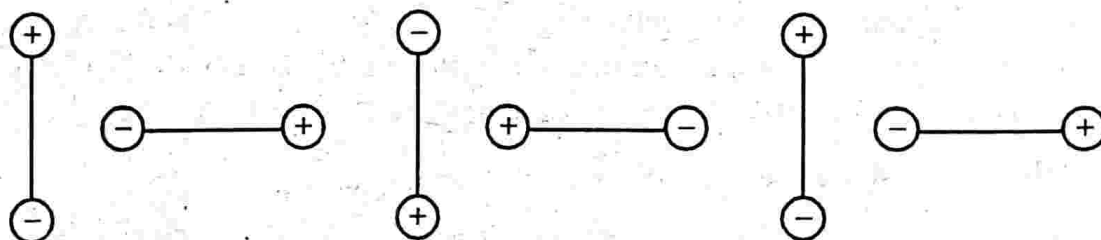

Figure 3.2

Here fluctuation of dipole moment takes place. Regular fluctuation of dipole moment results in interaction in which energy can be absorbed or emitted. This gives rise to a spectrum called rotation spectrum. The frequency of the spectrum corresponds to microwave region. Thus all molecules having a permanent dipole moment are said to be microwave active. On the other hand non polar molecules which do not have permanent dipole moment no interaction takes place and no spectrum. Thus non polar molecules are said to be microwave inactive.

3. Infrared region

This region extends from 3×10^{12} Hz to 3×10^{14} Hz (100 μ m to 1 μ m wavelength).

The spectrum arises due to vibrational motion of a molecule is called vibration spectrum. The study of vibration spectrum is called vibrational spectroscopy. The region of frequency of vibration spectra is in the infrared region. The energy change involved due to vibration of molecules is of the order of 10^4 joules / mole.

The vibration of molecule actually gives rise to change in dipole moment. There are three types of molecular vibration.

1. Symmetric stretching vibration.
2. Asymmetric stretching vibration.
3. Bending vibration

Symmetric stretching vibration

When a molecule is alternately stretched and compressed, the dipole moment remains zero during one complete vibration. Such a vibration is called symmetric stretching vibration. As there is no change in dipole moment occurs, this vibration is called infrared inactive.

For example consider the carbondioxide molecule in which the three atoms are arranged linearly. The carbon atom has a positive charge and oxygen atoms have negative charge. During symmetric stretch the molecule is alternately stretched and compressed. (see figure below).

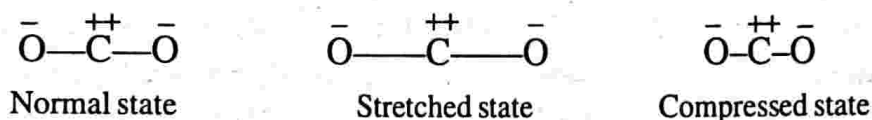

Figure 3.3

Asymmetric stretching vibration

When a linear molecule whose one bond stretches while the other bond compresses and vice-versa results in a vibration called asymmetric (Anti symmetric) stretching vibration. During this vibration the dipole moment of the molecule changes periodically. Thus the vibration is called infrared active. For example see the asymmetric stretching vibration of carbon dioxide molecule.

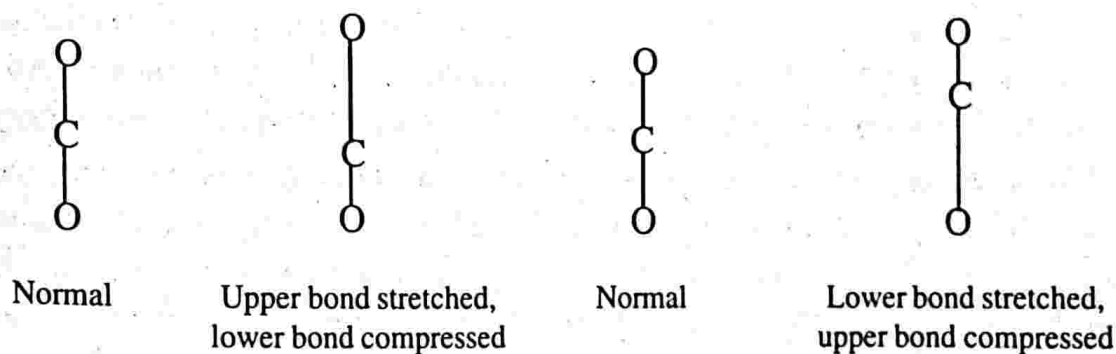

Figure 3.4

Bending vibration

A linear molecule whose bonds bend upwards making an angle then come to normal state then bonds bend downward and again come to normal state is called

bending vibration. For such a vibration the dipole moment of the molecule changes periodically and thus infrared active. For example see the figure of bending vibration of carbondioxide molecule.

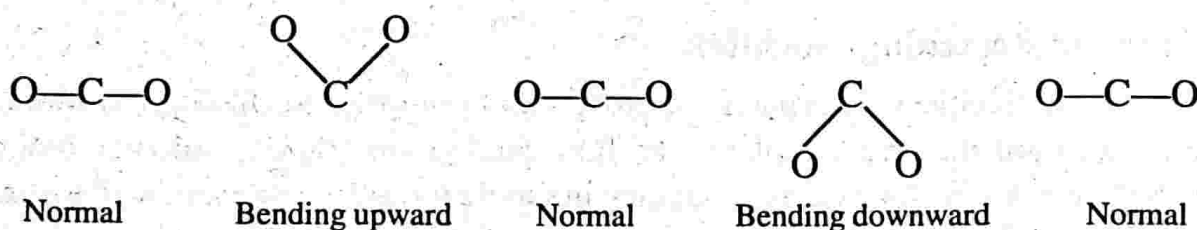

Figure 3.5

4. Visible and ultraviolet region

This region extends from 3×10^{14} Hz to 3×10^{16} Hz (1 μ m to 10nm wavelength).

When the valence electrons of an atom jump from one energy level to another level we get emission or absorption spectrum. It is called electronic spectrum and the study of electronic spectrum is known as electronic spectroscopy. The frequency region of electronic spectra lies in 3×10^{14} Hz to 3×10^{16} Hz. i.e., It lies in the visible and ultraviolet regions. The energy change involved is of the order of 10^5 joules / mole.

5. X-ray region

This region extends from 3×10^{16} Hz to 3×10^{18} Hz (10nm to 100pm wavelength).

When an electron strikes a target, before stopping it makes several collisions with the atoms in the target. It may interact with atoms in two ways.

- (i) When an electron interacts with the strong electric field of the atomic nucleus, consequently it is decelerated. According to classical electromagnetic theory, it would radiate electromagnetic energy continuously. This process can be thought as if the electron is emitting a series of photons with varying energy. An energetic electron passing through matter will radiate photons and lose energy.

The process by which photons are emitted by an electron slowing down is called bremsstrahlung (German word for braking radiation). These emitted photons are called X-rays. The X-rays produced in this process are called bremsstrahlung X-rays or continuous X-rays. The frequency of such X-ray lies in the above said region.

- (ii) When a high energy electron collides with one of the K-shell electrons in a target atom, enough energy may be transferred, to the K electron, the atom may be ionised. It will be left with a vacancy in its K shell. The atom is most stable in its lower energy state so an electron from one of the higher shells will change its

state and fill the inner shell vacancy at lower energy, emitting radiation. When this occurs in a heavy atom, we call the electromagnetic radiation emitted an X-ray. The photons emitted in such a manner are called characteristic X-rays.

The frequency of such X-rays lies in the above said region.

The energy changes involving the above said processes is of the order of 10^7 joules/ mole. The study of X-ray spectrum is called X-ray spectroscopy.

6. Gramma ray region

This region extends from 3×10^{18} Hz to 3×10^{20} Hz (100 pm to 1 pm wavelength).

It is due to rearrangement of nuclear particles electromagnetic radiations are emitted from a nucleus. These photons are called gamma rays. The energy change involved in this process is 10^9 to 10^{11} joules per atom and frequency range lies in the above said region. The study of the spectrum under this region of frequency is called γ -ray spectroscopy.

Apart from the six spectroscopies discussed, there is one more important spectroscopy called Raman spectroscopy discovered by sir C.V. Raman.

Representation of spectra

In this section we shall deal with how to record a spectrum. For this we use a grating spectrometer (Dispersive spectrometer). Grating spectrometer is suitable for use in the ultraviolet, visible and infrared regions of the spectrum.

Grating spectrometer

It consists of a source of radiation S. Usually a white source is taken as the source since it emits radiation over a wide range of frequencies. The radiation from the source is allowed to pass through a narrow slit S_1 and falls on a concave mirror M_1 from which a parallel beam of light is reflected onto a grating which is fixed on turn table. The grating reflects many frequencies at different angles. This reflected beam is allowed to fall on another concave mirror from which it is focussed to pass through a slit S_2 . From S_2 the radiation falls on M_3 by which it is focused on to the detector. Detector is placed at the focus of the mirror M_3 . Detector is a thermocouple for infrared radiation or a photomultiplier for visible and ultraviolet radiation. Depending upon the intensity of radiation falling on the detector, the detector gives an electric signal. This signal is amplified electronically and used to drive a pen which records the spectrum. The amplified signal can also be given to computer which can draw the spectrum and can be stored in it for future processing.

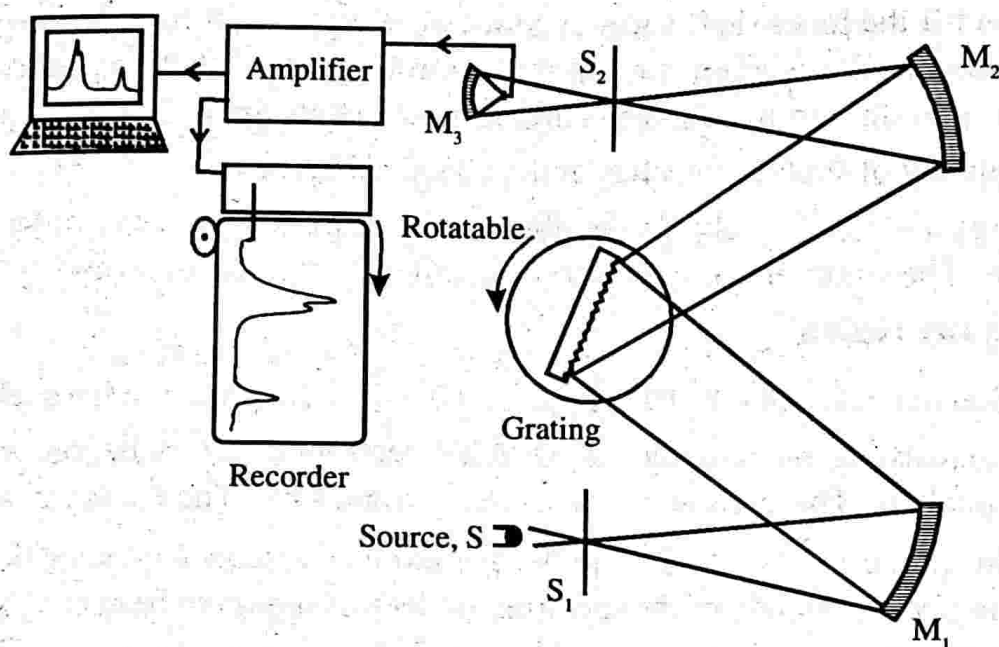

Figure 3.6: Grating spectrometer

Purpose of slits

1. Slits provide a sharply defined image which can be focussed on the detector.
2. Since the slits are made narrow, the frequency range of radiation which passes through the slits are smaller, consequently the resolving power of the instrument is increased.
3. Narrow slits prevent stray radiations coming from various components of spectrometer owing to scattering stray radiations entering the detector can make the recording false. This can be avoided to an extent using narrow slits.

Recording a spectrum

There are mainly two ways of recording a spectrum. One is the frequency domain spectrum, the other is the time domain spectrum. In the frequency domain spectrum we record the detector output against frequency. In the time domain spectrum we record the detector output against time. Here we shall discuss only frequency domain spectrum.

Now let us consider how a spectrum is recorded. If there is no sample present, detector output will be a constant over the range of frequencies covered by the instrument. This is only an ideal case. Now we shall see how to plot this on a chart paper. In frequency spectrum usually we plot percentage of frequency on the horizontal axis with increasing frequency and percentage detector output on the left vertical axis with 100% detector output as the origin and 0% at the top of the axis.

On the extreme right vertical axis we simultaneously mark the energy absorbed by the sample with zero energy absorbed as the starting point (at the bottom) and 100% energy absorbed at the top. When there is no sample the detector output will be 100% and will be a constant over the range of frequencies and the energy absorbed is zero. The corresponding frequency spectrum is shown in graph given below.

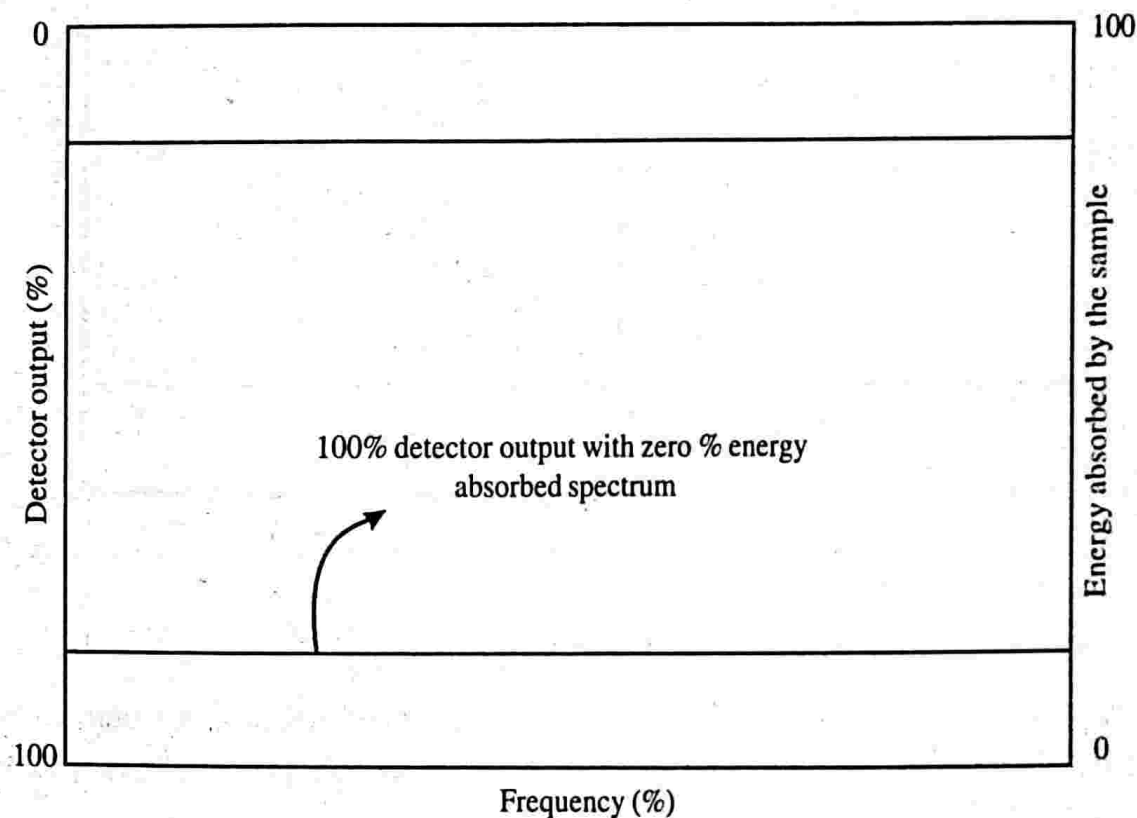

Figure 3.7

Now we imagine a substance placed in the path of the beam. The substance can be placed anywhere in the path of the beam. In order to minimise the size of the substance it is placed close to one of the slits S_1 or S_2 where the beam is narrow. Usually the substance is placed near the slit S_2 where the frequency range is small which is admitted by the grating. Suppose that our substance is having only two possible energy levels E_1 and E_2 . The frequency corresponding to these levels is

given by $\nu = \frac{E_2 - E_1}{h}$. Thus some energy at this frequency will be absorbed by the

substance (sample) from the radiation falling on it. As a result the detector output will show a sudden fall at this frequency. The corresponding frequency spectrum is shown in figure below.

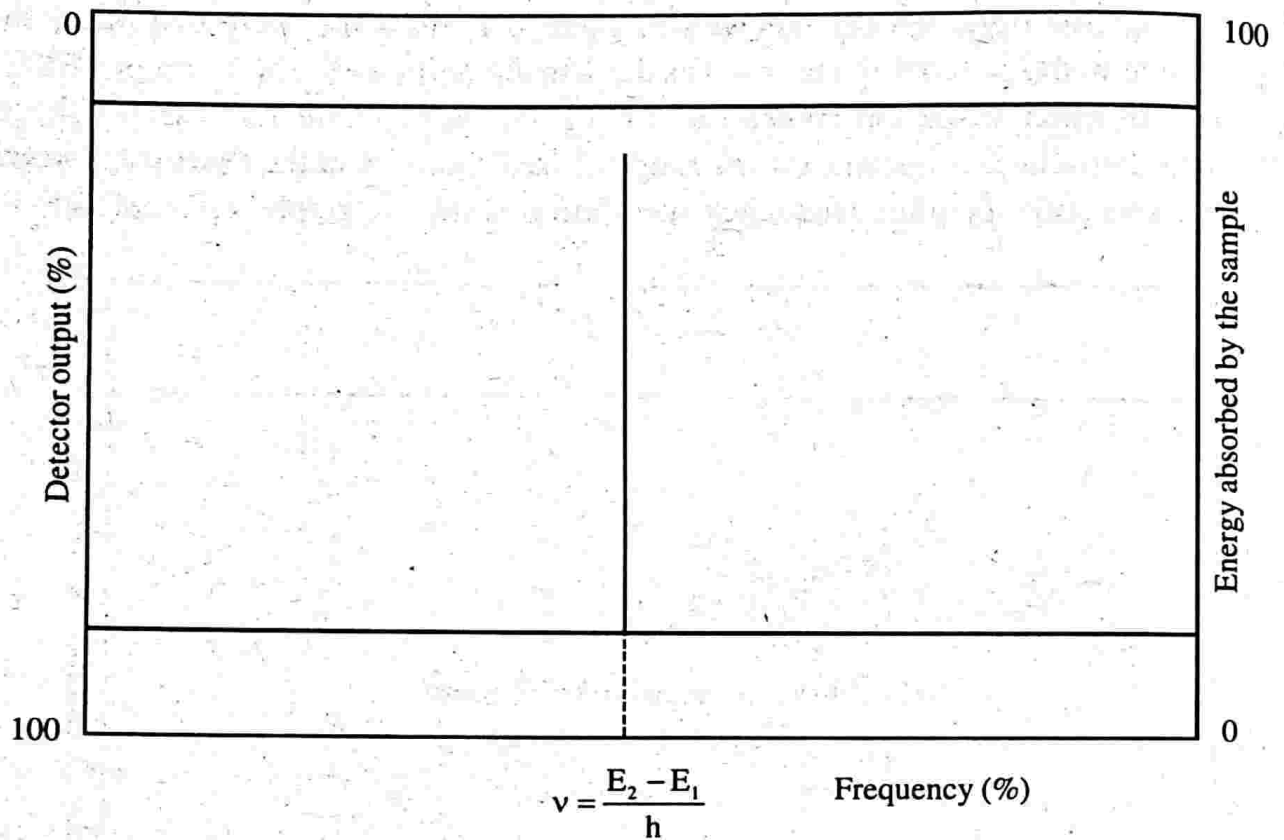

Figure 3.8

The above discussion of frequency spectrum is ideal and will not be obtained in practice. In actual practice so many other factors will come into play so the spectrum obtained will be different from that we already explained.

Factors affecting ideal spectrum

While drawing ideal spectrum we didn't say anything about the source emissivity and sensitivity of the detector. Actually both of them are frequency dependent. Because of this the horizontal line obtained in the case of no sample conditions will be no longer horizontal. Moreover the detector, the amplifier, the pen recorder etc. can disrupt the horizontal line and provide with larger number of extraneous frequencies arising from randomly generated electrical signals.

In ideal frequency spectrum we obtained a single frequency line spectrum. In actual practice this is not so. This is because a range of frequencies are falling on the detector rather than a single frequency since it is impossible to make the slit infinitesimally narrow. Apart from this the energy transitions in atoms or molecules don't occur at a single frequency but always occur over a range of frequencies. As a result the spectral absorption frequency line will be broadened. The actual frequency spec-

trum is shown in figure below. It may be noted that in this transmittance is plotted as the detector output and absorbance as the energy absorbed.

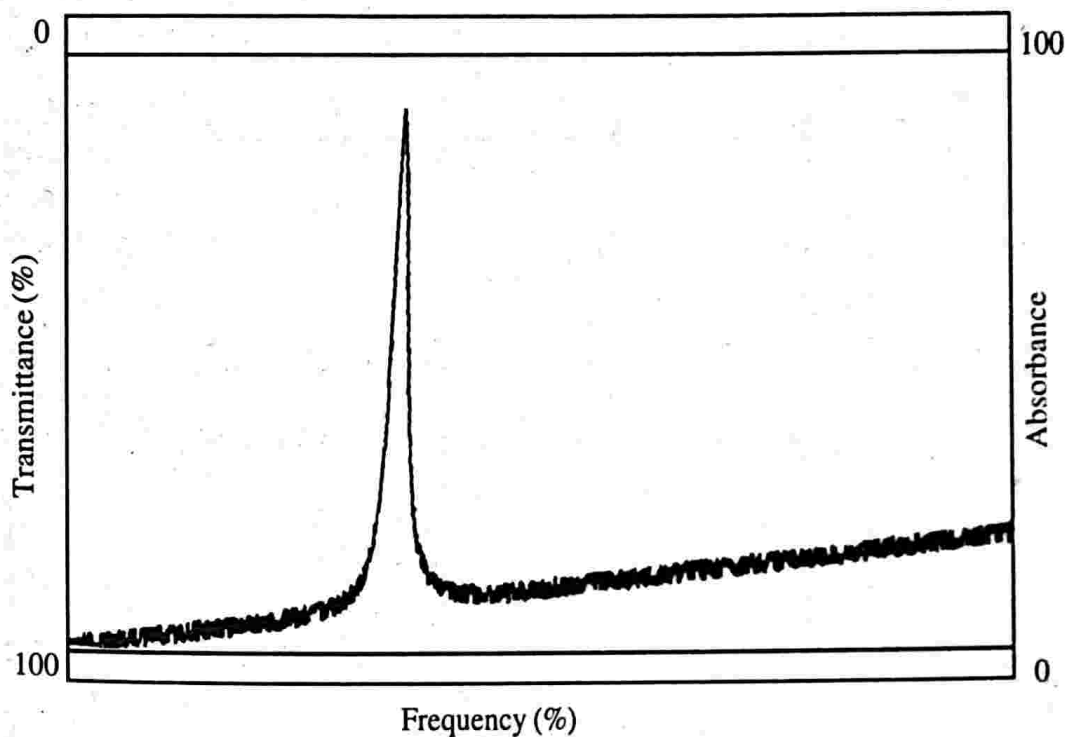

Figure 3.9

Note : - Transmittance $T_{\lambda} = \frac{I}{I_0}$, where I_0 is the intensity of incident radiation and I

is the intensity of radiation transmitted out of the sample. Whatever be the frequency range in which the spectrometer operate most of the modern spectrometers trace out the frequency spectrum as discussed above. However there is another very effective plotting method is followed, which is called the derivative of spectral trace. Here the derivative of energy absorbed or emitted is plotted against frequency. This has mainly two advantages over the former one. One is that from the absorbance trace we can exactly locate the centre of a absorbance peak. Because at this point the curve of absor-

bance (A) is horizontal hence its slope $\left(\frac{dA}{dv}\right)$ is zero. Secondly the half width

of the absorbance peak can be easily found out from the derivative curve see figure below. This type of tracing curve is adopted in electron paramagnetic resonance spectrometer.

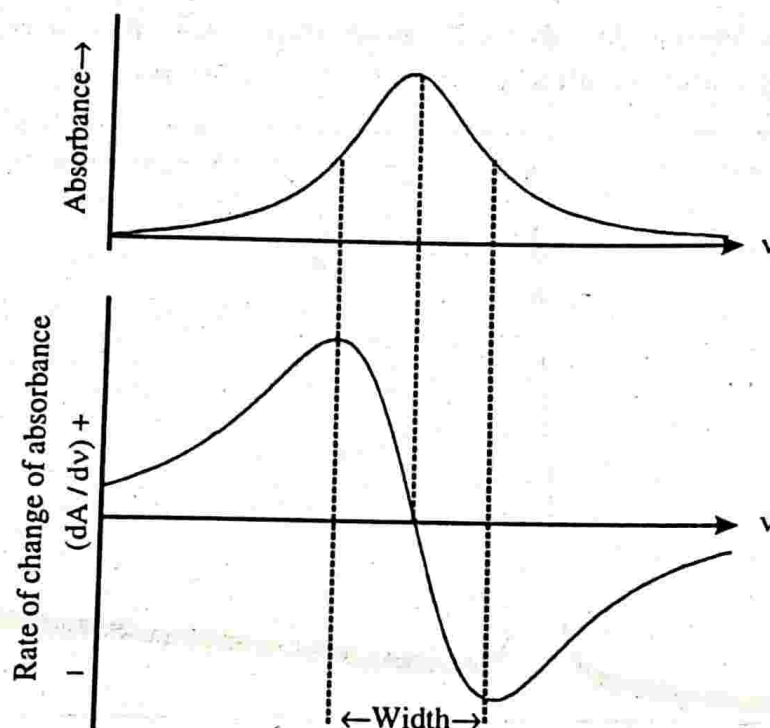

Figure 3.10

Basic elements of practical spectroscopy

Spectrometers play a vital role in the field of practical spectroscopy. Spectrometers used in various regions of spectrum differ widely from each other in construction. Here we shall discuss about the absorption and emission spectrometers whose basic features are common to all types of spectrometers.

Absorption spectrometer

It is of two types one used in the infrared, visible and ultraviolet regions and the other one used in the microwave and radio frequency regions. It consists of a radiation from a white source from which radiation is allowed to fall on a sample. The radiation coming out of the sample passes through an analyser (grating) which selects the frequency reaching the detector. The signal from the detector passes to a recorder which is synchronized with the analyser so as to produce a trace of the absorbance as the frequency varies. In between the sample and the analyser a modulator is placed. The modulator is an electronic device (or mechanical) which interrupts the radiation beam a certain number of times per second, usually between 10 and 1000 times. This is to cause the detector to send an alternating current signal to the recorder with a fixed frequency of 10-1000Hz. It has two advantages. One is the amplifier in the recorder is of a-c type which is in general simpler to construct and

more reliable in operation than a d. c. amplifier. The amplifier can be tuned to select only that frequency which the modulator imposes on the signals thus ignoring all other signals. In this way stray radiation and other extraneous signals are removed from the spectral trace.

In the microwave and radio frequency regions it is possible to construct monochromatic sources whose emission frequency can be varied over a range. In this case no separate analyser is required since source acts as its own analyser. As there is no analyser it is necessary for the recorder to be synchronised with the source - scanning device in order that a spectral trace be obtained.

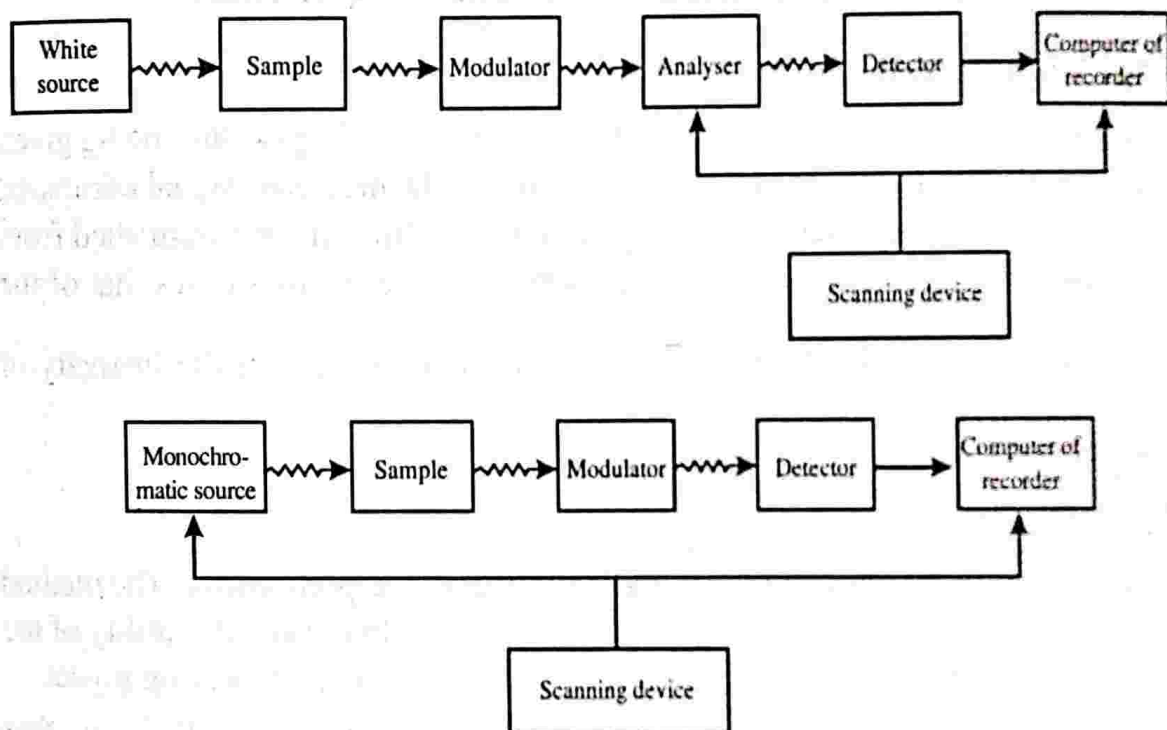

Figure 3.11

Emission spectrometer

It consists of a source of excitation, modulator, analyser, detector and a recorder placed as shown in figure. A sample is placed in between the modulator and the analyser. The analyser and the recorder are connected to a scanning device.

The excitation can be thermal or electrical but takes the form of electromagnetic radiation. The modulator is placed between the source of excitation and the sample, together with a tuned detector - amplifier, ensures that the only emission recorded from the sample arises directly from excitation. i.e., any other spontaneous emission is ignored.

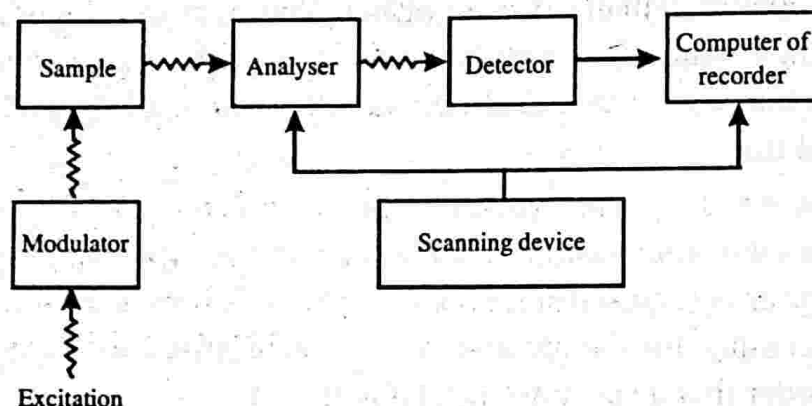

Figure 3.12: Block diagram of a typical emission spectrometer

Signal to noise ratio (S/N)

Signal to noise ratio is the signal divided by the noise, both quantities being given in the same units. It gives the relative importance of the measured signal compared to the noise in the measurement. The signal must be sufficiently distinguished from the noise, for this the intensity of the signal must be three or four times that of the

noise. i.e., $\frac{S}{N} = 3$ or 4. This requirement places a lower limit on the intensity of observable signal.

Resolving power

Resolving power actually measures the performance of a spectrometer. The method of separating two near by frequency spectra is called resolution and the ability of the spectrometer to produce separate frequency spectra is called its resolving power.

The resolving power actually depends upon the exit slit width. We know that molecular absorption takes place over a spread of frequencies. Usually this is very narrow. Let us consider two such frequency spectra lying close to each other. These spectra overlap in some region and become a single frequency spread as shown in figure. Suppose this spectra is allowed to pass through the exit slit of width larger than the frequency line width. In this situation both peaks of the spectra steadily passes through the slit and reaches the detector. Thus we can say that spectra is not resolved. If we decrease the slit width so that it allows only one peak to pass through. This shows that a narrower slit width would result in their resolution. This happens when the slit width is less than the separation between the frequency lines. But the narrow slit (high resolving power) brings a problem. A narrower slit allows only less energy to pass through. As a result the strength of the signal reaching the detector would be weak. Thus it is not possible to distinguish the signal from the noise. So we have to make a compromise between the resolving power and signal to noise

ratio. Thus in experimental spectroscopy we have to find the minimum slit width (maximum resolving power possible) consistent with acceptable signal to noise values.

Note: It may be noted that the above discussion about resolving power is not precise.

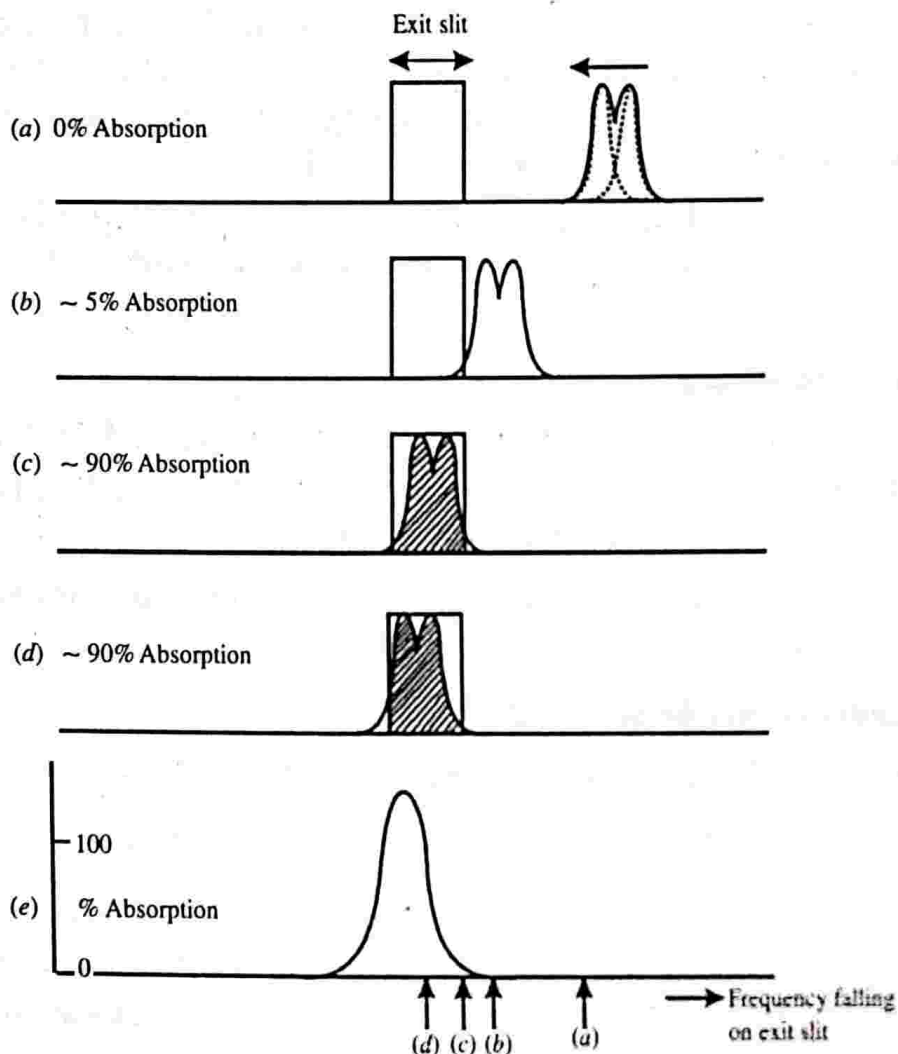

Figure 3.13: Illustrating the relationship between slit width and resolving power

The width and intensity of spectral transitions

The width and intensity are two properties of spectral transitions.

The width of spectral lines

We have seen that absorptions and emissions take place not at a single frequency but varied over a range. Thus the spectral lines obtained will be broadened and we have found that how the width of a spectral line is measured. The width of spectral lines arise because the energy levels of atomic and molecular systems are not precise. This occurs due to several factors such as collision broadening, Doppler broadening, Heisenberg uncertainty principle etc.

Collision broadening

Atoms and molecules in liquids and gases are in continual motion and collide frequently with each other. These collisions cause some deformations in the energy levels of outer most electrons. It is due to this visible and ultraviolet spectral lines have widths. It may be recalled that in visible and ultraviolet regions transitions occur in outer electronic shells. The collisions can also affect the vibrational and rotational spectra which explains the width of these spectral lines. When molecular interactions are strong we get more broadening. This is why spectra of gases are more sharp than those of the corresponding liquids.

In the case of solids interactions are less, thus we get sharp spectra. But solid spectral lines split into two or more components showing the evidence of interaction.

Doppler broadening

It is due to Doppler effect the particles show a Doppler shift (change in frequency). Since the motion is random the shift occurs in both lower and higher frequency regions. This results in the broadening of spectral lines.

In general, collision broadening is dominant in liquids where as Doppler broadening dominates in gases.

Uncertainty principle broadening

According to Heisenbergs energy-time uncertainty, we have

$$\Delta E \Delta t \approx \frac{h}{2\pi}$$

where ΔE is the energy uncertainty of a state in which the system stays for Δt second. h is the Plancks constant. If the system is in the ground state for an infinite time ($\Delta t = \infty$) then $\Delta E = 0$. i.e., energy uncertainty is zero. In otherwords ground state energy is sharply defined. However, the life time (Δt) of an excited electronic state is about 10^{-8} s.

$$\therefore \Delta E = \frac{h}{2\pi\Delta t} = \frac{6.62 \times 10^{-34}}{6.28 \times 10^{-8}} \approx 10^{-24}$$

\therefore The corresponding uncertainty associated with frequency is

$$\Delta \nu = \frac{\Delta E}{h} = \frac{10^{-24}}{6.6 \times 10^{-34}} \approx 10^8 \text{ Hz}$$

This is actually a large uncertainty. But this is small compared to the radiation

frequency of such transitions $10^{14} - 10^{16}$ Hz. So the natural line width is said to be small. But in the case of electron spin state $\Delta t \approx 10^{-7}$ s

$$\therefore \Delta\nu \approx 10^7 \text{ Hz}$$

This frequency is very large when compared with the usual frequency of such transitions, $10^8 - 10^9$ Hz. Thus spectral lines becomes broader. In this context broadening due to uncertainty principle becomes an important factor. In electronic transitions collision and Doppler broadening are more important.

The intensity of spectral lines

A spectral line is an isolated dark or bright line resulting from a deficiency or excess of photons in a narrow frequency range compared with nearby frequencies.

Intensity actually means the radiant flux passing through unit area in unit time.

In spectroscopy we usually measure the relative intensities of spectral lines. The intensity of spectral lines depends on

(i) The transition probability between the two states (selection rules)

(ii) Population of states $\frac{N_2}{N_1} = e^{-\frac{AE}{kT}}$

(iii) In absorption sample path length l and concentration c .

The relationship between concentration c , path length l and the incident (I_0) and transmitted intensities of radiation is written as

$$\frac{I}{I_0} = e^{-kcl} \quad \dots (1)$$

where k is a constant for the particular spectroscopic transition under investigation. The above equation can also be written in another form with base 10 instead of base e using base changing rule for convenience.

Taking log on both sides we get

$$\ln\left(\frac{I}{I_0}\right) = -kcl$$

$$\ln_e\left(\frac{I}{I_0}\right) = \ln_{10}(I/I_0) \ln_e 10$$

But $\ln_e 10 = 2.303$

$$\therefore 2.303 \ln_{10}(I/I_0) = -kcl$$

$$\text{or } \ln_{10}\left(\frac{I}{I_0}\right) = -\frac{k}{2.303}cl = -\epsilon cl$$

$$\text{or } \frac{I}{I_0} = 10^{-\epsilon cl} \quad \dots (2)$$

The ratio $\frac{I}{I_0}$ is called the transmittance and is denoted by T.

$$\therefore T = 10^{-\epsilon cl}$$

Here ϵ is called the molar absorption coefficient or decadic extinction coefficient. or decadic absorptivity (decadic meaning related to base 10).

From equation 2, we get

$$\log\left(\frac{I}{I_0}\right) = -\epsilon cl$$

$$\text{or } \log\left(\frac{I_0}{I}\right) = \epsilon cl = A$$

where A is called the absorbance or optical density.

The equation $A = \epsilon cl$ is called Beer-Lambert law.

Since absorbance of a sample is proportional to l and c of the absorbing species absorbance measurements are carried out in spectrometers rather than transmittance

$\left(\frac{I}{I_0}\right)$ which depends on l and c exponentially.

IMPORTANT FORMULAE

1. Energy quantisation: $E_2 - E_1 = h\nu$

2. Expression for transmittance:

$$T_\lambda = \frac{I}{I_0}$$

I_0 is the intensity of the incident radiation and I is the intensity radiation transmitted out.

3. Uncertainty principle:

$$\Delta E \Delta t = \frac{h}{2\pi}$$

$$\Delta E = h\Delta\nu$$

or

$$\Delta\nu = \frac{\Delta E}{h} \approx \frac{1}{2\pi\Delta t}$$

4. Intensity of spectral lines:

(i) Population of states, $N_2 = N_1 e^{-\frac{\Delta E}{kT}}$

(ii) The relation between concentration C , path length l , the incident intensity (I_0) and the transmitted intensity (I) radiation

$$\frac{I}{I_0} = e^{-kcl}$$

or

$$\frac{I}{I_0} = 10^{-\epsilon kl}, \quad \epsilon = \frac{k}{2.303}$$

$$\frac{I}{I_0} = T \quad \text{Transmittance}$$

$$T = 10^{-\epsilon kl}$$

5. Beer-Lambert law: $A = \epsilon cl$

UNIVERSITY MODEL QUESTIONS

Section A

(Answer questions in two or three sentences)

Short answer type questions

1. What is spectroscopy?

2. What is meant by quantization of energy?
3. Which are the three types of energies possessed by a molecule?
4. Classify spectroscopy in accordance with electromagnetic spectrum.
5. Why a polar molecule is said to be microwave active?
6. What is meant by microwave inactive molecules?
7. Which are the three types of molecular vibrations?
8. What are the factors affecting ideal spectrum?
9. Give the block diagram of absorption spectrometer.
10. Draw the block diagram of emission spectrometer.
11. Define signal to noise ratio. What is its physical significance?
12. What are the properties of spectral line transitions?
13. What are the factors on which the intensity of spectral line depend.
14. Define (i) transmittance (ii) absorbance.
15. What is the relation between transmittance and absorbance?
16. What are the factors on which absorbance of a sample depend?
17. Write down the Beer-Lambert law and explain the symbols.

Section B

(Answer questions in a **paragraph** of about half a page to one page)

Paragraph / Problem type questions

1. Briefly explain N.M.R.
2. Briefly explain E.S.R.
3. Explain briefly the symmetric stretching vibration of a molecule.
4. Explain the asymmetric stretching vibration of a molecule.
5. Explain the bending vibration of a molecule.
6. Explain how collision of atoms or molecules in liquids and gases leads to broadening of spectral lines.
7. Explain the Doppler broadening of spectral lines.
8. Explain the broadening of spectral lines due to uncertainty principle.
9. How does the widening of the slits in a spectrometer affect its resolution?

Section C

(Answer questions in about **two** pages)

Long answer type questions (Essays)

1. What is a grating spectrometer? Explain the recording of a spectrum with diagram.

4

MICROWAVE SPECTROSCOPY

Introduction

Spectroscopy in the microwave region is called microwave spectroscopy and is concerned with the study of rotating molecules. In other words microwave spectroscopy deals with rotational spectra. This spectra is due to transitions between different rotational levels. If the transition occurs within the same vibrational level we obtain a pure rotational spectra. Actually the region of spectra would be in the microwave or far infrared region. The study of rotational spectra provides a direct method for the evaluation of molecular parameters. This study of rotational spectra has been made use of in the construction of the microwave oven.

Classification of molecules

We know that the rotation of a body can be described in terms of rotational inertia called moment of inertia (I). The same can also be used in the case of molecules. To describe a molecule we require three principal moments of inertia I_A , I_B and I_C about three mutually perpendicular axes. In general the three axes are chosen in such a way that $I_A < I_B < I_C$. Based on the relative values of principal moments of inertia I_A , I_B and I_C , the molecules are classified into four groups. They are (1) linear molecules (2) symmetric tops (3) spherical tops and (4) asymmetric tops.

1. Linear molecules

The molecules in which atoms are arranged in a straight line are called linear molecules. HCl , CO_2 , OCS , HCN , C_2H_2 etc. are linear molecules.

Here I_A is the moment of inertia of the molecule about the molecular axis, I_B is the moment of inertia about an axis passing through the centre of gravity of the molecule and perpendicular to the molecular axis and I_C is the moment of inertia about an axis passing through the centre of gravity perpendicular to both A and B axes. See figure 4.1.

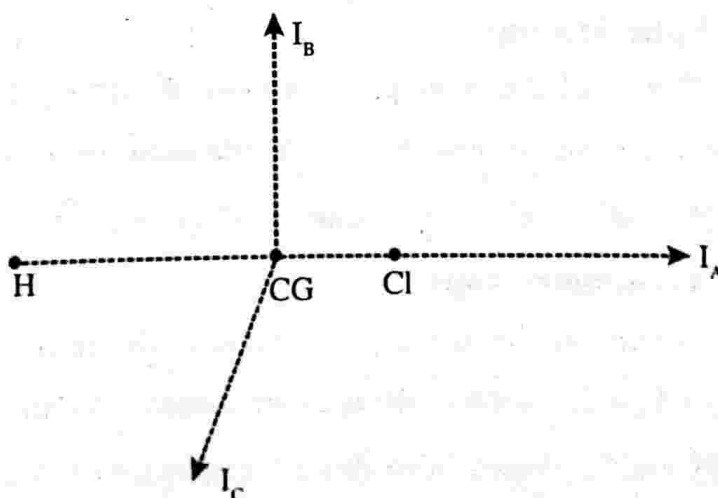
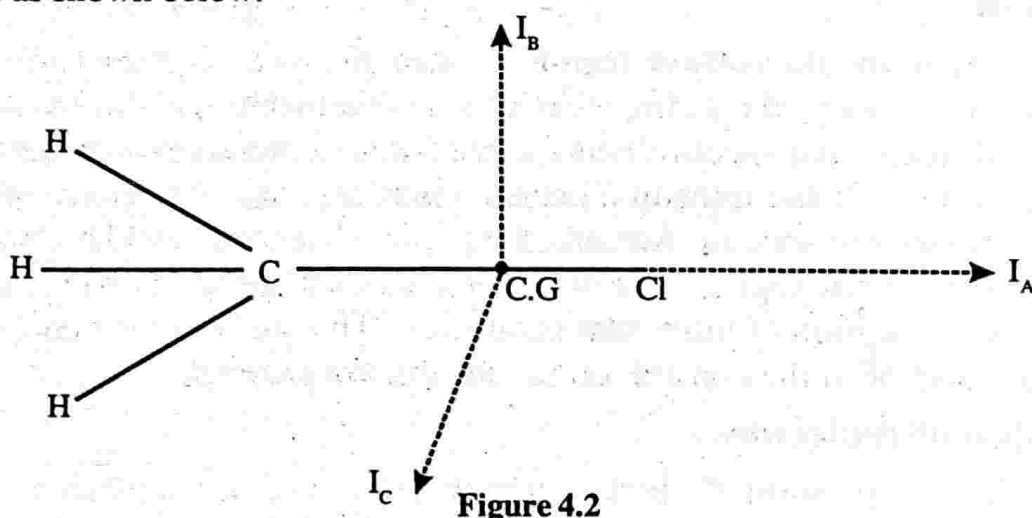

Figure 4.1

It is from the definition of I_A , I_B and I_C it is obvious that $I_A = 0$ and $I_B = I_C$. Thus a linear molecule is described by $I_A = 0$ and $I_B = I_C$.

2. Symmetric tops

In symmetric tops molecules $I_A \neq 0$ and $I_B = I_C$. Consider a molecule such as CH_3Cl , where the three hydrogen atoms are attached (bonded) tetrahedrally to the carbon as shown below.



A molecule of this type spinning about A axis resembles a spinning top and hence the name symmetric top. This type molecules can further be divided into two classes depending on whether I_A is smaller or greater with respect to I_B .

If $I_A < I_B = I_C$ they are called prolate symmetric top and if $I_A > I_B = I_C$ they are called oblate symmetric top. CH_3Cl , CH_3F , CH_3CN , NH_3 etc. are examples of prolate symmetric top molecules and BF_3 , BCl_3 are examples of oblate symmetric top molecules.

3. Spherical tops

When all the principal moments of inertia of a molecule are equal, it is called a spherical top molecule. i.e., A spherical top molecule is described by $I_A = I_B = I_C$. CH_4 , SF_6 , CCl_4 are examples of spherical tops.

4. Asymmetric tops

When all the principal moments of inertia of a molecule are different i.e., $I_A \neq I_B \neq I_C$, such molecules are called asymmetric top molecule. H_2O , CH_3OH , CH_2OHCl (vinyl chloride) are examples of this. Majority of the molecules belong to this group.

Rotational spectra

The rotational energy like all other forms of molecular energy is also quantised. This means that a molecule cannot have any arbitrary amount of rotational energy but its energy is limited to a certain definite values depending on the shape and size of the molecule. This permitted values of energy are called rotational energy levels. In principle rotational energy levels can be calculated by solving the Schrödinger equation for the system represented by that molecule. For simple molecules solving Schrödinger equation is straight forward but tedious, while for complicated system of molecules it is impossible to solve Schrödinger equation without approximations. In our study we are not bothered about solving Schrödinger equation but we take the results of existing solution and point out where reasonable approximation may lead.

Interaction of radiation with rotating molecule

When an electromagnetic radiation of proper frequency interacts with rotating molecule, rotational energy transition takes place. In this way we get a rotation spectrum. For this to happen the molecule must have a permanent dipole moment.

Consider a diatomic molecule having a dipole moment which will be along the bond. When the molecule rotates about an axis perpendicular to the bond, the direction of the dipole moment changes continuously resulting in a periodic variation in a given direction. This generates a fluctuating electric field which interacts with the electric field of the electromagnetic radiation leading to pure rotational spectrum. This shows that energy can be exchanged only if the molecule has a permanent

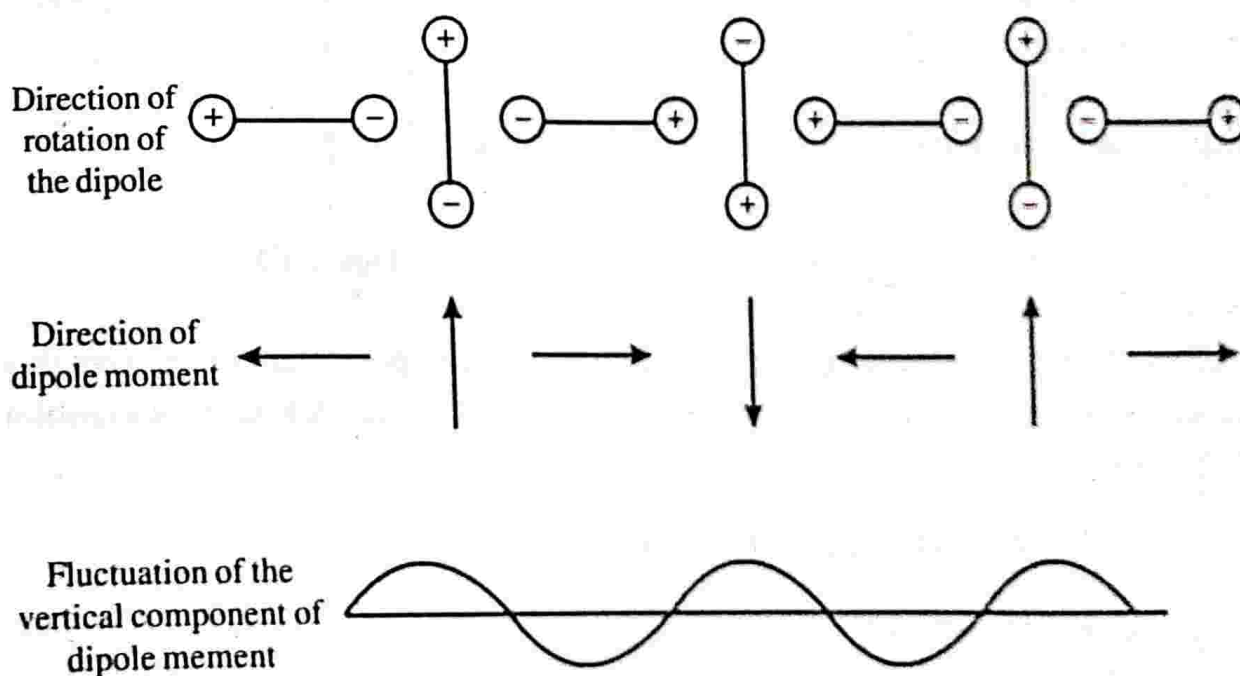

Figure 4.3

dipole moment. If the permanent dipole moment is zero there will not be any periodic variation. In the case of symmetric top and spherical top molecules, no rotational spectra are observed since they have no dipole moment owing to their symmetry.

If ψ_i and ψ_j are the wave functions for the rotational states i and j , the transition moment μ_{ij} is given by

$$\mu_{ij} = \int \psi_i^* \mu \psi_j d\tau$$

$\mu_{ij} \neq 0$ only if the molecule has a permanent dipole moment. The allowed transitions are governed by the selection rule $\Delta J = \pm 1$, J is the rotational quantum number.

Rigid diatomic molecules (Rigid rotator)

Rigid rotator is the simplest model of a molecule. It consists of two atoms of masses m_1 and m_2 connected by a rigid bond of length r . This is a two body problem and can be reduced to an equivalent one body problem, consisting of reduced mass

$$\mu = \frac{m_1 m_2}{m_1 + m_2}$$

at a distance r from the centre

of mass of the two atoms. The only motion that can be quantised is the molecule about the axis passing through the centre of mass and perpendicular to the line joining the two atoms. Such a model is called a rigid rotator in a plane.

Motion of such a motion can be described in terms of a single coordinate θ , the angle of rotation of the axis of the molecule. In a such a case, the potential energy remains constant during the motion, since the distance does not change. Angular momentum of the rotator is

$$L = \mu v r = \mu r \cdot v = \mu r \cdot r \omega = \mu r^2 \omega$$

$$L = I \omega \quad (\mu r^2 = I)$$

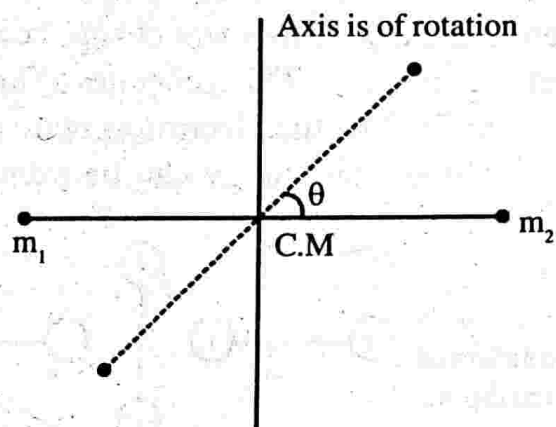

Figure 4.4

where I is the moment of inertia of the rotator about the axis of rotation. According to Bohr - sommerfeld quantisation rule, we have

$$\oint L d\phi = nh$$

$$\int_0^{2\pi} L d\phi = nh$$

If L is constant we have

$$L \cdot 2\pi = nh$$

$$L = \frac{nh}{2\pi} = n\hbar \text{ where } n = 0, 1, 2, \dots$$

Allowed energy values are therefore

$$E_n = \frac{L^2}{2I} = \frac{n^2 \hbar^2}{2I}$$

where E_n is the kinetic energy. This picture is due to old quantum theory. But this theory has been superseded by the new quantum theory or quantum mechanics.

To get the allowed energy values in the realm of quantum mechanics we have to solve the schrodinger for the rigid rotator. This gives

$$E_l = \frac{\hbar^2}{2I} l(l+1), \quad l = 0, 1, 2, 3, \dots$$

where l is the orbital quantum number.

Evaluation of I of a rigid rotator

The moment of inertia of the rigid rotator about an axis passing through its centre of mass and perpendicular to the molecular axis

$$I = m_1 r_1^2 + m_2 r_2^2 \quad \dots (1)$$

From the concept of centre of mass of two particle system, we have

$$m_1 r_1 = m_2 r_2$$

Using $r_1 + r_2 = r$ (see figure)

$$r_2 = r - r_1$$

$$\therefore m_1 r_1 = m_2 (r - r_1)$$

or $r_1(m_1 + m_2) = m_2 r$

$$r_1 = \frac{m_2 r}{m_1 + m_2}$$

Similarly $r_2 = \frac{m_1 r}{m_1 + m_2}$

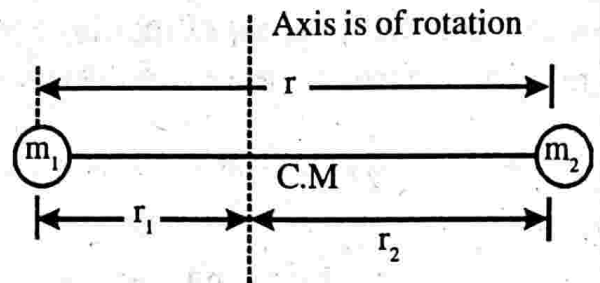

Figure 4.5

Putting the values of r_1 and r_2 in equn. (1) we get

$$I = m_1 \left(\frac{m_2 r}{m_1 + m_2} \right)^2 + m_2 \left(\frac{m_1 r}{m_1 + m_2} \right)^2$$

$$I = \frac{m_1 m_2^2 r^2}{(m_1 + m_2)^2} + \frac{m_2 m_1^2 r^2}{(m_1 + m_2)^2} = \frac{m_1 m_2 r^2 (m_1 + m_2)}{(m_1 + m_2)^2}$$

$$I = \frac{m_1 m_2}{m_1 + m_2} r^2 = \mu r^2$$

Rotational spectrum of rigid diatomic molecule

We could see that a molecule can be considered as a rigid rotator. The energy eigen value is given by

$$E_j = \frac{\hbar^2}{2I} J(J+1), \quad J = 0, 1, 2, \dots$$

where J is the rotational quantum number (the angular momentum quantum number l is redesignated as J just to follow the standard symbols used in standard spectroscopy text books). To analyse the rotational spectrum energy is expressed in wave number (ϵ_j) units for convenience.

$$\epsilon_j = \frac{1}{\lambda} = \frac{v}{c} = \frac{h\nu}{hc} = \frac{E_j}{hc}$$

or
$$\epsilon_j = \frac{\hbar^2 J(J+1)}{2I hc} = \frac{\hbar}{4\pi Ic} J(J+1) = \frac{h}{8\pi^2 Ic} J(J+1)$$

$$\epsilon_j = BJ(J+1) \quad \dots (1)$$

where B is the rotational constant and is given by

$$B = \frac{h}{8\pi^2 Ic} \quad \dots (2)$$

If h , I and c are expressed in cgs, B has the unit cm^{-1} .

From eqn. (1), we can draw the energy level diagram. See figure below.

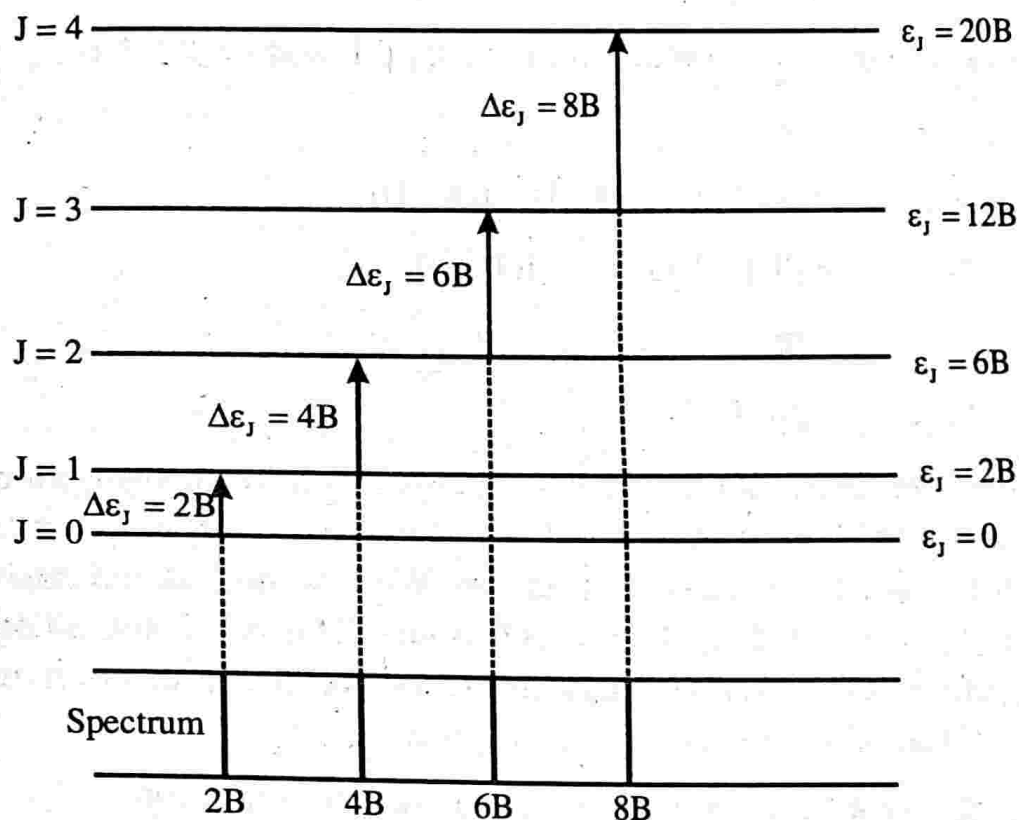

Figure 4.6 : Rotational energy levels and transitions for a rigid diatomic molecule

Denoting the lower state by J'' and upper state by J' , From eqn (1) we get

$$\epsilon_{J'} = B = J'(J'+1) \quad \dots (3)$$

$$\epsilon_{J''} = B = J''(J''+1) \quad \dots (4)$$

Eqn (3)-Eq (4) gives

$$\epsilon_{J'} - \epsilon_{J''} = B [J'(J'+1) - J''(J''+1)]$$

$$\Delta\epsilon_j = B[J'(J'+1) - J''(J''+1)] \quad \dots (5)$$

If we imagine the molecule to be in the ground rotational state ($J'' = 0$) and let the incident radiation be absorbed to raise it to the next higher state ($J' = 1$). Then

$$\Delta\varepsilon_{J=0 \rightarrow 1} = 2B$$

If the molecule is raised from $J = 1$ to $J = 2$ (i.e., $J'' = 1$ and $J' = 2$)

$$\Delta\varepsilon_{J=1 \rightarrow 2} = B = [2(2+1) - 1(1+1)]$$

$$\Delta\varepsilon_{J=1 \rightarrow 2} = 4B$$

If the molecule is raised from $J = 2$ to $J = 3$ (i.e., $J'' = 2$ and $J' = 3$)

$$\Delta\varepsilon_{J=2 \rightarrow 3} = 6B$$

In general, to raise the molecule from the state J to state $J + 1$ (i.e., $J'' = J$ and $J' = J + 1$)

$$\therefore \Delta\varepsilon_{J \rightarrow J+1} = B[(J+1)(J+1+1) - J(J+1)]$$

$$\Delta\varepsilon_{J \rightarrow J+1} = B[(J+1)(J+2) - J(J+1)]$$

$$= B[J^2 + 3J + 2 - J^2 - J]$$

$$\Delta\varepsilon_{J \rightarrow J+1} = 2B(J+1) \quad \dots (6)$$

Thus a stepwise raising of the rotational energy results in an absorption spectrum consisting of spectral lines at $2B, 4B, 6B, \dots$. Similarly a stepwise lowering of the rotational energy results in emission spectrum. We have considered raising or lowering to the immediate level i.e., J changes by unity. This is because all other transitions are spectroscopically forbidden. Such a result is called a selection rule. For the rigid rotator (Diatomic) the selection rule is given by

$$\Delta J = \pm 1, \text{ plus sign for absorption and minus sign for emission.}$$

From the spectral lines obtained, the value of B can be deduced from the spacing between the lines. Knowing B , I can be evaluated using equation 2. From the value of $I(\mu r^2)$, the internuclear distance (r) of the diatomic molecule can be calculated.

Bond length of CO and the valid of the theory

Gilliam, Johnson and Gordy have measured the first line ($J = 0$) in the rotation spectrum of carbon monoxide as 3.84235 cm^{-1} . From eqn (6), we have

$$\Delta E_{J=0 \rightarrow 1} = 3.84235 = 2B$$

$$\therefore B = 1.92118 \text{ cm}^{-1}$$

$$\therefore I = \frac{h}{8\pi^2 c B} \quad \left(\because B = \frac{h}{8\pi^2 I c} \right)$$

$$I = \frac{6.626 \times 10^{-34} \text{ kgm}^2}{8 \times 3.14^2 \times 2.99793 \times 10^{10} \times 1.92118}, \text{ here } B \text{ is in } \text{cm}^{-1} \text{ and } c \text{ is in } \text{cm s}^{-1}$$

$$I = 14.5695 \times 10^{-47} \text{ kgm}^2$$

$$\text{Using } I = \mu r^2 = \frac{m_1 m_2}{m_1 + m_2} r^2 = \frac{m_c m_o}{m_c + m_o} r^2$$

$$\frac{m_c m_o}{m_c + m_o} = \frac{19.92178 \times 10^{-27} \times 26.5613 \times 10^{-27}}{(19.92178 + 26.5613) \times 10^{-27}}$$

$$= 11.38365 \times 10^{-27} \text{ kg}$$

$$\therefore r^2 = \frac{I}{\mu} = \frac{14.5695 \times 10^{-47}}{11.38365 \times 10^{-27}} = 1.2799 \times 10^{-20} \text{ m}^2$$

$$\therefore r_{co} = 0.1131 \text{ nm} = 1.131 \text{ \AA}$$

This is in well agreement with the experimental results.

Note :- Knowing the relative atomic weights to be C = 12 and O = 15.9994 if H = 1.0080.

Absolute mass of hydrogen atom = $1.67343 \times 10^{-27} \text{ kg}$

$$\therefore m_c = \frac{12 \times 1.67343 \times 10^{-27}}{1.008} = 19.92178 \times 10^{-27} \text{ kg}$$

$$\text{and } m_o = \frac{15.9994 \times 1.67343 \times 10^{-27}}{1.008} = 226.5613 \times 10^{-27} \text{ kg}.$$

Intensities of spectral lines

The pure rotational spectrum of a diatomic molecule is due to the change in rotational energy levels. These energy levels are quantised. When a molecule rotates from its allowed rotational energy level to the nearest allowed energy level, a spectrum (equally spaced spectral lines) is obtained. The allowed transitions are governed by the selection rule $\Delta J = \pm 1$. Here our aim is to estimate the relative intensities of spectral lines. The intensity of a spectral lines depends upon the number of molecules present in each level. This is given by Boltzmann's distribution function. Moreover each level is $(2J + 1)$ fold degenerate. (see foot note)

If N_J is the number of molecules in the J^{th} state we have

$$N_J \propto (2J+1)e^{-\frac{E_J}{kT}}$$

or
$$N_J \propto (2J+1)e^{-\frac{Bhc J(J+1)}{kT}}$$

where
$$E_J = \frac{h^2}{8\pi^2 I} J(J+1) \text{ with } B = \frac{h}{8\pi^2 Ic}$$

when N_J is plotted against J , we get a graph as shown below. The curve shows that the population rises to a maximum then diminishes. Maximum population means maximum intensity. In other words intensity will be maximum corresponding to nearest integral J value.

To get to the J value corresponding to maximum N_J , differentiate N_J with respect to J and put equal to zero.

We have

$$N_J = A(2J+1)e^{-DJ(J+1)}$$

where
$$D = \frac{Bhc}{kT}$$

$$\therefore \frac{dN_J}{dJ} = A(2J+1)e^{-DJ(J+1)} \times -D(2J+1) + 2Ae^{-DJ(J+1)}$$

$$0 = -AD(2J+1)^2 e^{-DJ(J+1)} + 2Ae^{-DJ(J+1)}$$

or
$$AD(2J+1)^2 e^{-DJ(J+1)} = 2Ae^{-DJ(J+1)}$$

or
$$D(2J+1)^2 = 2$$

$$(2J+1)^2 = \frac{2}{D}$$

$$(2J+1) = \sqrt{\frac{2}{D}}$$

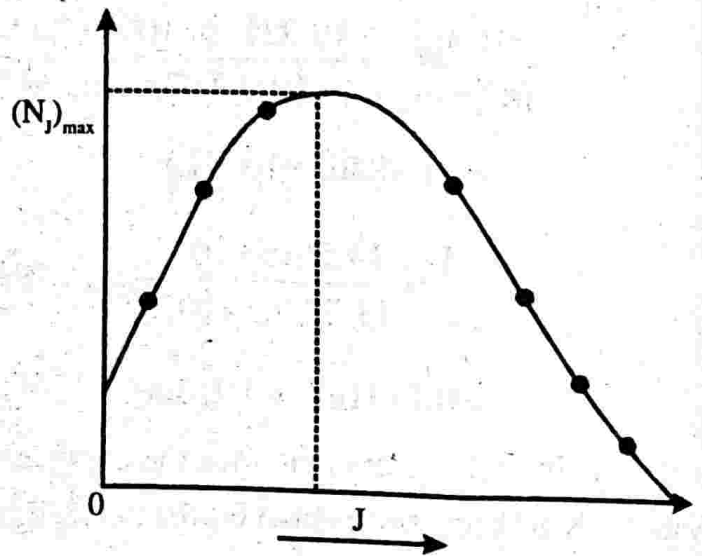

Figure 4.7

$$2J = \sqrt{\frac{2}{D}} - 1$$

$$\therefore J = \sqrt{\frac{1}{2D}} - \frac{1}{2}$$

Putting the value of D

$$J = \sqrt{\frac{kT}{2hcB}} - \frac{1}{2}$$

The transition from this level will have maximum intensity.

Degeneracy of energy level

An energy level is said to be degenerate if there exists two or more levels corresponding to same energy. The number of energy levels possible with same energy is called degeneracy. Here we shall estimate the degeneracy of a rigid rotator for a given J value. The energy and angular momentum of a rigid rotator are given by

$$E = \frac{1}{2} I \omega^2 \quad \text{and} \quad L = I \omega$$

or
$$E = \frac{1}{2} \frac{I^2 \omega^2}{I} = \frac{L^2}{2I}$$

or
$$\bar{L} = \sqrt{2EI} \quad \dots (1)$$

Putting the expression for E

$$\bar{L} = \sqrt{2 \times \frac{\hbar^2}{2I} J(J+1)I} = \hbar \sqrt{J(J+1)}$$

$$\bar{L} = \hbar \sqrt{J(J+1)} \quad \dots (2)$$

\hbar is taken as the unit of angular momentum.

Equation (1) shows that same energy level means same angular momentum vector. For a given J, \bar{L} has a constant value according to equation 2. Since \bar{L} being a vector this constant vector length will have different orientations with respect to a given reference direction.

when $J = 1$ $\bar{L} = \sqrt{2}$

A vector length $\sqrt{2}$ can have three orientations with respect to reference direction. (see figure below). i.e., $J = 1$ is three fold degenerate.

Similarly for $J = 2$, $\bar{L} = \sqrt{6}$, we get 5 different orientations and for $J = 3$, $\bar{L} = \sqrt{12}$ we get 7 different orientations. In general we can say for a given J , there are $2J + 1$ orientations. see figure below.

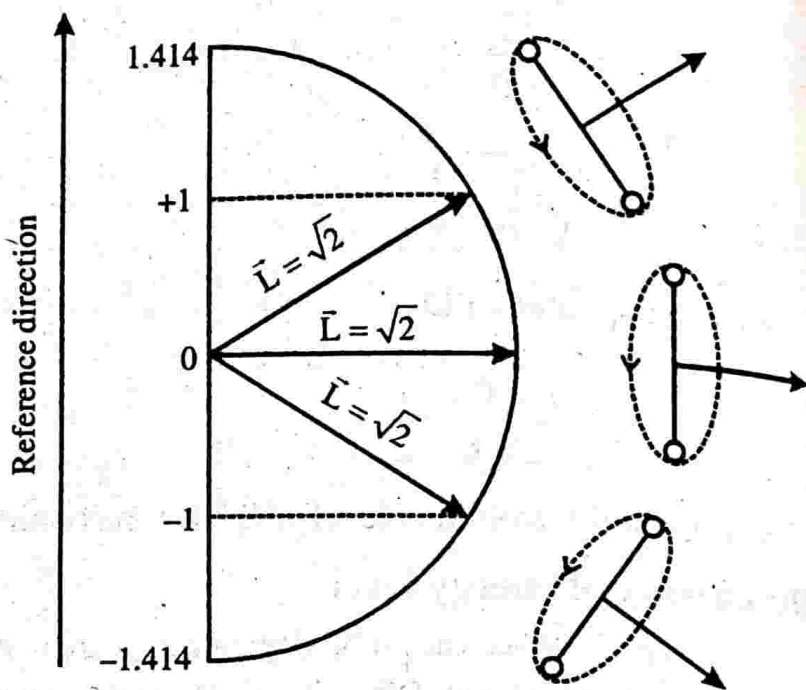
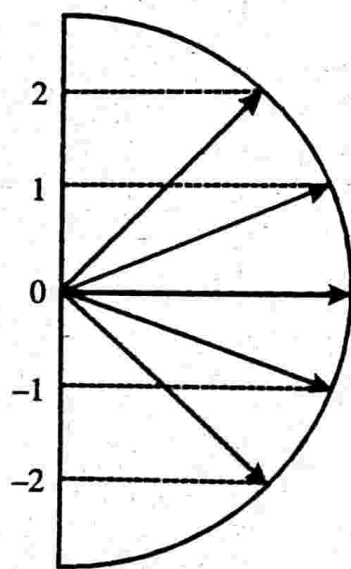
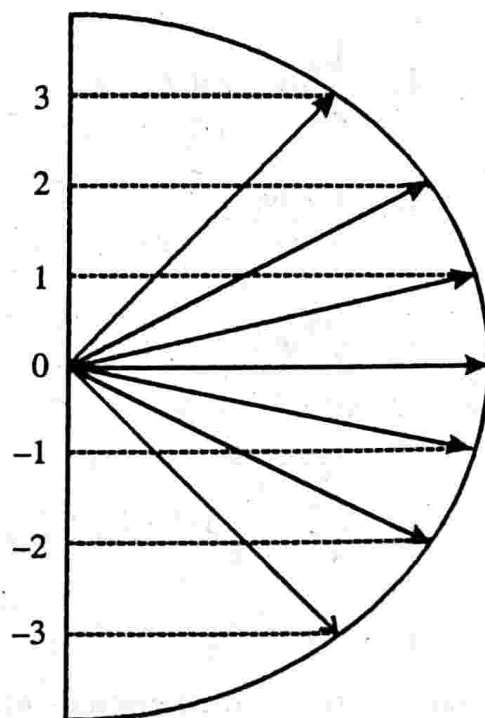

Figure 4.8



For $J = 2$, degeneracy 5



For $J = 3$, degeneracy 7

Figure 4.9

Example 1

What is the change in rotational constant B when hydrogen is replaced by deuterium in hydrogen molecule.

Solution

$$\text{We have } B = \frac{h}{8\pi^2 I c} = \frac{h}{8\pi^2 \mu r^2 c}$$

or $B \propto \frac{1}{\mu}$

$$\text{For hydrogen molecule } \mu = \frac{m_H m_H}{m_H + m_H} = \frac{m_H}{2}$$

$$\therefore B \propto \frac{2}{m_H} \quad \dots (1)$$

When one hydrogen is replaced by deuterium

$$B' \propto \frac{1}{\mu'}$$

$$\text{For deuterium } \mu' = \frac{m_D m_D}{m_D + m_D} = \frac{m_D}{2} = \frac{2m_H}{2} = m_H$$

$$\therefore B' \propto \frac{1}{m_H} \quad \dots (2)$$

$$\frac{\text{Eq(2)}}{\text{Eq(1)}} \rightarrow \frac{B'}{B} = \frac{1}{2}$$

or $B' = \frac{B}{2}$

\therefore Change in rotational constant

$$B - B' = B - \frac{B}{2} = \frac{B}{2}$$

Example 2

The rotational constant for H^{35}Cl is found to be 10.5909 cm^{-1} . What is the value of B for H^{37}Cl .

Solution

$$B = 10.5909 \text{ cm}^{-1} \text{ for } \text{H}^{35}\text{Cl}.$$

If B' is the rotational constant for H^{37}Cl .

Then we have

$$\frac{B'}{B} = \frac{\mu}{\mu'} \quad \left(\because B \propto \frac{1}{\mu} \right)$$

$$\mu = \frac{m_{\text{H}} \times {}^{35}\text{m}_{\text{Cl}}}{m_{\text{H}} + {}^{35}\text{m}_{\text{Cl}}} = \frac{m_{\text{H}} \times 35m_{\text{H}}}{m_{\text{H}} + 35m_{\text{H}}} = \frac{35}{36} m_{\text{H}}$$

$$\mu' = \frac{m_{\text{H}} \times {}^{37}\text{m}_{\text{Cl}}}{m_{\text{H}} + {}^{37}\text{m}_{\text{Cl}}} = \frac{37}{38} m_{\text{H}}$$

$$\therefore \frac{B'}{B} = \frac{35}{36} \times \frac{38}{37} = 0.9985$$

$$\text{or } B' = 0.9985 \times B = 9985 \times 10.5909 \\ = 10.5750 \text{ cm}^{-1}$$

Example 3

The microwave spectrum of CN radical shows a series of lines spaced by a nearly constant amount of 3.798 cm^{-1} . What is the bond length of CN?

Solution

$$2B = 3.798 \text{ cm}^{-1} \text{ (given)}$$

$$B = 1.899 \text{ cm}^{-1}$$

$$\text{Using } B = \frac{h}{8\pi^2 I c}$$

$$I = \frac{h}{8\pi^2 B c}$$

$$I = \frac{6.626 \times 10^{-34}}{8 \times \pi^2 \times 1.899 \times 3 \times 10^{10}} \text{ kgm}^2$$

$$I = 14.7304 \times 10^{-47} \text{ kgm}^2$$

We have

$$I = \mu r^2$$

$$\mu = \frac{m_C \times m_N}{m_C + m_N} = \frac{12m_H \times 14.003m_H}{12m_H + 14.003m_H} = 6.4622m_H$$

$$\mu = \frac{6.4622}{1.008} \times 1.67343 \times 10^{-27} \text{ kg}$$

$$= 10.7282 \times 10^{-27} \text{ kg}$$

$$r = \sqrt{\frac{14.7304 \times 10^{-47}}{10.7282 \times 10^{-27}}} = 1.1718 \times 10^{-10} \text{ m}$$

$$r = 1.1718 \text{ \AA}$$

Example 4

How many revolutions per second does a CO molecule make when $J = 3$. The CO bond length is 0.1131 nm. Avagadro number 6.022×10^{23} .

Solution

$$r = 0.1131 \times 10^{-9} \text{ m}$$

Reduced mass of CO molecule

$$\mu = \frac{m_C \times m_O}{m_C + m_O} = \frac{12 \times 15.9949}{(12 + 15.9949) \times 6.022 \times 10^{23}} \text{ g}$$

$$\mu = 1.1385 \times 10^{-26} \text{ kg}$$

$$I = \mu r^2 = 1.1385 \times 10^{-26} \times (0.1131 \times 10^{-9})^2$$

$$= 0.1456 \times 10^{-45} \text{ kgm}^2$$

We have rotational energy

$$\frac{1}{2} I \omega^2 = \frac{h^2}{8\pi^2 I} J(J+1)$$

$$\omega = \frac{h \sqrt{J(J+1)}}{2\pi I}$$

$$\nu = \frac{h\sqrt{J(J+1)}}{4\pi^2 I}$$

$$\nu = \frac{6.626 \times 10^{-34} \sqrt{3(3+1)}}{4 \times \pi^2 \times 0.1456 \times 10^{-45}}$$

$$\nu = 39.93 \times 10^{10} \text{ Hz}$$

Example 5

The first rotational line of $^{12}\text{C}^{16}\text{O}$ is observed at 3.84235cm^{-1} and that of $^{13}\text{C}^{16}\text{O}$ at 3.67337cm^{-1} . Calculate the atomic weight of ^{13}C , assuming the mass of ^{16}O to be 15.9949.

Solution

$$B = 3.84235 \quad \text{--- for } ^{12}\text{C}^{16}\text{O}$$

$$B' = 3.67337 \quad \text{--- for } ^{13}\text{C}^{16}\text{O}$$

$$\frac{B}{B'} = \frac{\mu'}{\mu}$$

$$\text{But } \mu = \frac{{}^{12}m_{\text{C}} \times m_{\text{O}}}{{}^{12}m_{\text{C}} + m_{\text{O}}} = \frac{12 \times 15.9949}{(12 + 15.9949)(6.02 \times 10^{23})}$$

$$\mu' = \frac{{}^{13}m_{\text{C}} \times m_{\text{O}}}{{}^{13}m_{\text{C}} + m_{\text{O}}} = \frac{m \times 15.9949}{(m + 15.9949)(6.02 \times 10^{23})}$$

$$\frac{\mu'}{\mu} = \frac{m \times 15.9949}{m + 15.9949} \times \frac{27.9949}{12 \times 15.9949}$$

Substituting B, B', μ and μ' in eqn (1), we get

$$\frac{3.84235}{3.67337} = \frac{m \times 15.9949}{m + 15.9949} \times \frac{27.9949}{12 \times 15.9949}$$

$$1.046 = \frac{m \times 15.9949}{m + 15.9949} \times 0.14585$$

$$\frac{1.046}{0.14585} = \frac{15.9949m}{m + 15.9949}$$

$$7.1715m + 7.17175 \times 15.9949m$$

$$7.1715 \times 15.9949 = 15.9949m - 7.17175m$$

$$114.71142 = 8.82315m$$

$$m = \frac{114.71142}{8.82315m} = 13.001$$

Atomic weight of ^{13}C is 13.001

Example 6

The average spacing between successive rotational line of carbon monoxide is 3.8626 cm^{-1} . Determine the transition which gives the most intense spectral line at 300K.

Solution

$$2B = 3.8626\text{ cm}^{-1} \text{ (given)}$$

$$B = 1.9313\text{ cm}^{-1}$$

$$T = 300\text{ K}$$

For the most intense spectral line

$$J = \sqrt{\frac{kT}{2hcB}} - \frac{1}{2}$$

$$J = \sqrt{\frac{1.381 \times 10^{-23} \times 300}{2 \times 6.626 \times 10^{-34} \times 3 \times 10^{10} \times 1.9313}} - \frac{1}{2}$$

$$J = 7.3456 - 0.5$$

$$J = 6.8456$$

Therefore most intense line is obtained for $J = 7$.

Example 7

The $J = 0 \rightarrow 1$ transition in HCl occurs at 20.68 cm^{-1} . Regarding the molecule to be a rigid rotator, calculate the wavelength of the transition $J = 14 \rightarrow 15$.

Solution

$$2B = 20.68 \text{ cm}^{-1}$$

$$B = 10.34 \text{ cm}^{-1}$$

We have

$$\epsilon_j = 2B(J+1)$$

$$\epsilon_j = 2 \times 10.34(14+1) = 310.2 \text{ cm}^{-1}$$

$$\therefore \text{Wavelength } \lambda = \frac{1}{\epsilon_j} = \frac{1}{310.2} = 32 \times 10^{-4} \text{ cm}$$

$$\lambda = 32 \times 10^{-6} \text{ m}$$

Example 8

The OH radical has a moment of inertia of $1.48 \times 10^{-47} \text{ kgm}^2$. Calculate its inter-nuclear distance. Also calculate for $J = 5$, its angular momentum and angular velocity.

Solution

$$I = 1.48 \times 10^{-47} \text{ kgm}^2$$

$$\mu = \frac{m_H \times m_O}{m_H + m_O} = \frac{1 \times 16}{(1+16) 6.023 \times 10^{26}}$$

$$\mu = 1.563 \times 10^{-27} \text{ kg}$$

Using $I = \mu r^2$

$$r = \sqrt{\frac{I}{\mu}} = \sqrt{\frac{1.48 \times 10^{-47}}{1.563 \times 10^{-27}}} = 9.731 \times 10^{-11} \text{ m}$$

Angular momentum is given by

$$L = \frac{h}{2\pi} \sqrt{J(J+1)}$$

$$L = \frac{6.62 \times 10^{-34} \sqrt{J(J+1)}}{2 \times 3.14} = 5.77 \times 10^{-34} \text{ Js}$$

$$\omega = \frac{L}{I} = \frac{5.77 \times 10^{-34}}{1.48 \times 10^{-47}} = 3.9 \times 10^{13} \text{ rads}^{-1}$$

IMPORTANT FORMULAE

1. The allowed rotational energy levels of a rigid diatomic molecule.

$$E_J = \frac{\hbar^2}{2I} J(J+1), \quad J = 0, 1, 2, \dots$$

where

$$I = \mu r^2 \quad \text{with} \quad \mu = \frac{m_1 m_2}{m_1 + m_2}$$

In terms of wave number

$$\epsilon_J = BJ(J+1), \quad \epsilon_J = \frac{1}{\lambda}$$

where

$$B = \frac{h}{8\pi^2 Ic}$$

2. The value of rotational quantum number (J) corresponding to maximum intensity.

$$J = \sqrt{\frac{kT}{2hcB}} - \frac{1}{2}$$

3. The angular momentum of a rigid diatomic molecule.

$$\bar{L} = J(J+1)\hbar$$

4. The frequency of diatomic molecule

$$\nu = \frac{h\sqrt{J(J+1)}}{4\pi^2 I}$$

5. Selection rule for rotational spectrum.

$$\mu_{ij} \neq 0, \quad \Delta J = \pm 1$$

6. The number of molecules in the J^{th} state

$$N_J \propto (2J+1)e^{-\frac{E_J}{kT}}$$

where $E_J = BhcJ(J+1)$ with $B = \frac{h}{8\pi^2 Ic}$.

UNIVERSITY MODEL QUESTIONS**Section A**

(Answer questions in two or three sentences)

Short answer type questions

1. Classify molecules according to their rotational inertia.
2. What is a linear molecule? Give two examples.
3. What is a symmetric top molecule? Give two examples.
4. What is a spherical top molecule? Give two examples.
5. What are asymmetric tops? Give two examples.
6. Spherical top molecules do not show rotational spectrum. Explain why?
7. Distinguish between prolate and oblate symmetric top molecules.
8. What is a rigid rotator?
9. Comment on rotational quantum number.
10. Write down the expression for energy eigen value of a rigid rotator and explain the symbols.
11. What is rotational constant? How does it influence a spectrum?
12. Draw the rotational energy levels and transitions for a rigid diatomic molecule.
13. What is a selection rule? What is it for a rigid rotator?
14. What are the factors on which the intensity of rotational spectra depend.
15. What is meant by degeneracy of eigen value?
16. How does the elasticity of bond length influence the rotational constant?
17. Give two informations derived from rotational spectra.
18. How will you evaluate the bond length of a molecule from rotational constant?
19. Write down the selection rule for the molecular spectrum of rigid symmetric top molecule.
20. Depict a schematic representation of energy levels and transitions for the rigid prolate and the rigid oblate symmetric top molecules.
21. Write down the equation for the energy levels of rigid prolate symmetric top molecule.

Section B

(Answer questions in a paragraph of about half a page to one page)

Paragraph / Problem type questions

1. Briefly explain how does electromagnetic radiation interact with rotating molecule.
2. Molecules having permanent dipole moment exhibit rotational spectrum. Explain why.
3. Evaluate the moment of inertia of a diatomic molecule.
4. Derive an expression for the rotational constant B.

5. How will you establish the validity of the theory of rotation spectra of rigid diatomic molecule?
6. Derive an expression for the rotational quantum number corresponding to maximum intensity rotational spectra.
7. What is the change in rotational constant B when ^{12}C of carbon monoxide ($^{12}\text{C } ^{16}\text{O}$) is replaced by ^{13}C . B of $^{12}\text{C } ^{16}\text{O}$ is 1.92118cm^{-1} . [0.08449]
8. The rotational constant of H^{35}Cl is found to be 10.5009cm^{-1} . What is the value of $^{2}\text{D } ^{35}\text{Cl}$? [5.446 cm^{-1}]
9. How many revolutions per second does CO molecule make when $J = 4$? The rotational constant of CO molecule is 1.9313cm^{-1} . [51.822 $\times 10^{10}$ Hz]
10. The separation between lines in the rotational spectrum of HCl molecule was found to be 20.92cm^{-1} . Calculate the bond length. [1.282 Å]
11. The rotational spectrum of $^{79}\text{Br } ^{19}\text{F}$ shows a series of equidistant lines 0.71433cm^{-1} apart. Calculate the rotational constant B, and hence moment of inertia and bond length of the molecule. $^{79}\text{Br} = 131.03 \times 10^{-27}\text{kg}$, $^{19}\text{F} = 31.55 \times 10^{-27}\text{kg}$.
[B = 0.35717cm^{-1} , I = $7.837 \times 10^{-46}\text{kgm}^2$, r = $1.756 \times 10^{-10}\text{m}$]
12. In the above problem find which transition gives rise to the most intense spectral line at temperature 300K. [J = 17]
13. Evaluate the moment of inertia of a rigid rotator $\left[I = \frac{m_1 m_2}{m_1 + m_2} r^2 \right]$
14. Find the expression for the J value for which intensity of spectral line is maximum.
15. Calculate the rotational energy levels of HCl molecule in eV. Given bond length $r = 0.13\text{nm}$ [1.26 $\times 10^{-3}$ J(J+1)eV]
16. The moment of inertia of the CO molecule is $1.46 \times 10^{-46}\text{kgm}^2$. Calculate the energy in eV, and the angular velocity in the lowest rotational energy level of the CO molecule. [4.74 $\times 10^{-4}$ eV, 1.0193 $\times 10^{12}$ rad/s]

Section C

(Answer questions in about two pages)

Long answer type questions (Essays)

1. Obtain an expression for the rotational energy levels of a diatomic molecule taking it as a rigid rotator.

Hints to problems

1 to 6 See book work

$$7. \quad \frac{B}{B'} = \frac{\mu'}{\mu}, \quad \mu = \frac{{}^{12}\text{m}_C \times \text{m}_O}{{}^{12}\text{m}_C + \text{m}_O}, \quad {}^{12}\text{m}_C = 12, \quad \text{m}_O = 15.9994$$

$$\mu' = \frac{{}^{13}\text{m}_C \times \text{m}_O}{{}^{13}\text{m}_C + \text{m}_O}, \quad {}^{13}\text{m}_C = 13.001$$

$$\frac{\mu'}{\mu} = 1.046$$

$$\text{i.e., } \frac{B}{B'} = 1.046$$

$$B' = \frac{B}{1.046}, \quad B = 1.92118$$

\therefore Change in $B = B - B'$

8. See example 2

$$9. \quad \frac{1}{2} I \omega^2 = \frac{h^2}{8\pi^2 I} J(J+1)$$

$$\omega^2 = \frac{h^2}{4\pi^2 I^2} J(J+1) \quad \text{use } B = \frac{h^2}{8\pi^2 I c} \quad B^2 = \frac{h^2}{64\pi^4 I^2 c^2}$$

$$\omega^2 = 16\pi^2 c^2 B^2 J(J+1)$$

$$\omega = 4\pi c B \sqrt{J(J+1)}$$

$$2\pi\nu = 4\pi c B \sqrt{J(J+1)}$$

$$\nu = 2cB \sqrt{J(J+1)}$$

$$\nu = 2 \times 3 \times 10^{10} \times 1.9313cB \sqrt{4 \times (4+1)}$$

$$\nu = 51.822 \times 10^{10} \text{ Hz (see also example 4)}$$

10. $2B = 20.92 \text{ cm}^{-1}$ given

$$\text{Using } B = \frac{h}{8\pi^2 I c}$$

$$I = \frac{h}{8\pi^2 B c} = \frac{6.626 \times 10^{-34}}{8 \times \pi^2 \times 10.46 \times 3 \times 10^{10}}$$

$$I = 2.6743 \times 10^{-47} \text{ kgm}^2$$

$$I = \mu r^2$$

$$\therefore r = \sqrt{\frac{I}{\mu}}$$

$$\mu = \frac{m_{\text{H}} \times m_{\text{Cl}}}{m_{\text{H}} + m_{\text{Cl}}} = \frac{1.673 \times 10^{-27} \times 58.06 \times 10^{-27}}{(1.673 + 58.06) \times 10^{-27}}$$

$$\mu = 1.6261 \times 10^{-27} \text{ kg}$$

11. See example 3
12. See example 6
13. See book work
14. See book work

$$15. \mu = \frac{1.008 \times 35.46}{1.008 + 35.46 \times 6.023 \times 10^{26}} = 1.627 \times 10^{-27} \text{ kg}$$

$$I = \mu r^2 = 1.627 \times 10^{-27} \times (0.13 \times 10^{-9})^2 = 2.75 \times 10^{-47} \text{ kgm}^2$$

$$E_j = \frac{h^2}{8\pi^2 I} J(J+1) = \frac{(6.616 \times 10^{-34})^2 J(J+1)}{8\pi^2 \times 2.75 \times 10^{-47} \times 1.6 \times 10^{-19}}$$

$$16. E_j = \frac{h^2}{8\pi^2 I} J(J+1), J=1 \text{ given}$$

Find E_j and convert into eV.

$$E_j = \frac{1}{2} I \omega^2$$

or

$$\omega = \sqrt{\frac{2E_j}{I}}$$

5

INFRARED SPECTROSCOPY

Introduction

The spectroscopy in the infrared region is concerned with the study of vibrating molecules. In the last chapter we could see that how the elasticity of bond length results in the vibration of molecule. The consequence of the elasticity is that the atoms in a molecule do not remain fixed in relative positions but vibrate about some mean position. It is due to vibration, molecules possess vibrational energy and this energy is quantised. When the molecule goes from one vibrational level to another energy is released or absorbed gives rise to a spectra called vibrational spectra. The wavelength region of the spectra is in the infrared. Hence the study of vibrational spectra is called infrared spectroscopy. This study gives us valuable information regarding molecular structure, symmetry, bond strength, inter and intramolecular interactions etc.

To develop the theory we have to make models to vibrating molecules. Here we shall deal with two models. One is simple harmonic oscillator model another one is the anharmonic oscillator model.

The vibrational energy of a diatomic molecule - (Harmonic oscillator model)

Here we assume that a diatomic molecule behaves like an oscillating spring - mass system. i.e., two masses m_1 and m_2 connected by a spring with force constant k . Here m_1 and m_2 are masses of two atoms and the elastic bond acts like a spring which obeys

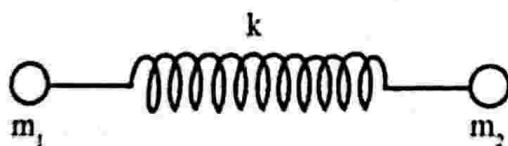

Figure 5.1

Hooke's law. If r_e is the distance between the two atoms in equilibrium. i.e., r_e is the equilibrium bond length. Suppose the bond is distorted from its equilibrium length r_e to new length r . The bond, like a spring, obeys Hooke's law. Then the restoring force f is given by

$$f = -k(r - r_e)$$

where k is the restoring force.

Then the potential energy of the system has the form

$$U = \frac{1}{2}k(r - r_c)^2$$

i.e., the energy curve is parabolic. This model of a vibrating molecule is called simple harmonic oscillator model. The frequency of such a motion is given by

$$\nu_0 = \frac{1}{2\pi} \sqrt{\frac{k}{\mu}}$$

Here μ is called the reduced mass of the system given by

$$\mu = \frac{m_1 m_2}{m_1 + m_2}$$

Now consider the diatomic molecule as a simple harmonic oscillator with potential energy $U = \frac{1}{2}k(r - r_c)^2$ and treat the problem quantum mechanically, we can arrive at the energy eigen values possessed by the diatomic molecule due to vibration. For this we have to solve the corresponding Schrodinger equation. After solving we arrive at the vibrational energy of such a harmonic system. This is given by

$$E_v = \left(v + \frac{1}{2}\right) h\nu_0, \quad v = 0, 1, 2, \dots \quad \dots (1)$$

where v is called the vibrational quantum number.

Converting this into spectroscopic units, we have

$$\begin{aligned} \epsilon_v &= \frac{E_v}{hc} = \left(v + \frac{1}{2}\right) \frac{h\nu_0}{hc} = \left(v + \frac{1}{2}\right) \frac{\nu_0}{c} \\ \epsilon_v &= \left(v + \frac{1}{2}\right) \bar{\nu}_0 \quad \left(\frac{\nu_0}{c} = \frac{1}{\lambda} = \bar{\nu}_0\right) \quad \dots (2) \end{aligned}$$

where $\bar{\nu}_0$ is the vibrational frequency of the oscillator in wave numbers. Its unit is cm^{-1} .

From equation (1) it is seen that the energy levels are equally spaced.

i.e.,
$$E_0 = \frac{1}{2} h\nu_0$$

$$E_1 = \frac{3}{2} h\nu_0$$

$$E_2 = \frac{5}{2} h\nu_0$$

$$E_3 = \frac{7}{2} h\nu_0$$

i.e., $E_3 - E_2 = E_2 - E_1 = E_1 - E_0 = \frac{1}{2} h\nu_0$. More over it is seen that the lowest energy possible is

$$E_0 = \frac{1}{2} h\nu_0.$$

This is called zero point energy. That is vibrational energy is not zero even at the lowest vibrational level. This shows that a molecule always vibrates.

The selection rule for the harmonic oscillator undergoing vibrational changes is

$$\Delta v = \pm 1$$

This shows that the transitions are allowed only to adjacent vibrational levels.

Vibrational energy changes will only give rise to an observable spectrum if the vibration can interact with radiation. i.e., if the vibration involves a change in the dipole moment of the molecule. Thus vibrational spectra will be observable only in heteronuclear diatomic molecules like HF, HCl, HBr etc. Homonuclear molecules like H_2 , N_2 and O_2 show no vibrational spectrum since they have no dipole moment.

From eqn (2) it is seen that

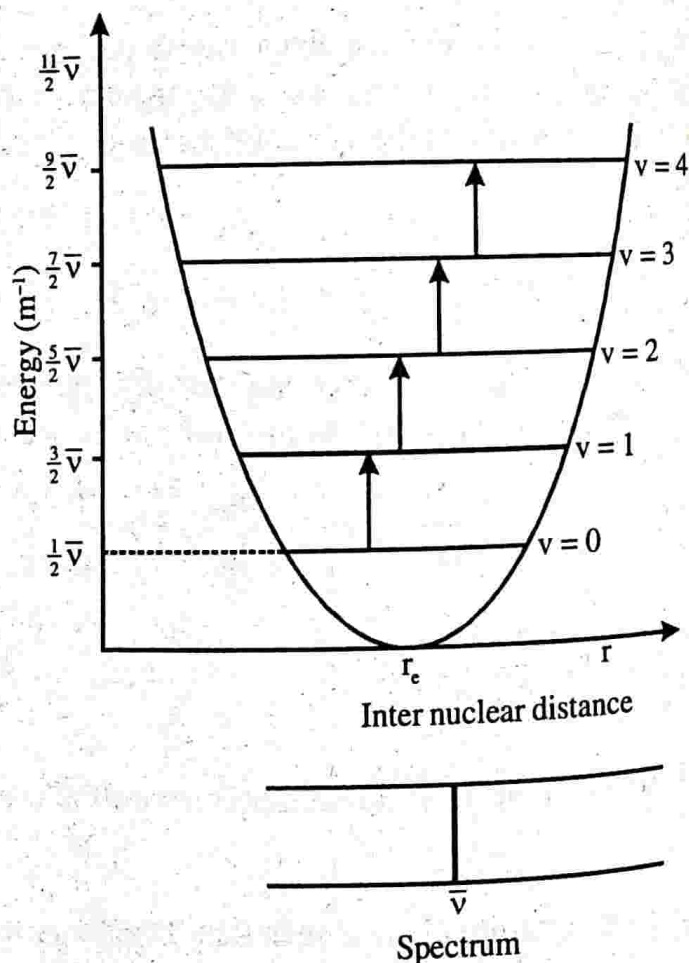

Figure 5.2

when a molecule goes from its vibrational level v to $v+1$, all the vibrational lines obtained from harmonic oscillator are of the same frequency. The allowed vibrational energy levels and transitions between them for a diatomic molecule undergoing simple harmonic motion are shown in figure.

In reality molecules do not obey the laws of simple harmonic motion. This is because real bonds, though which are elastic do not obey Hooke's law. So we have to resort to the second model - anharmonic oscillator model.

The anharmonic oscillator model

When we come to real molecules they do not obey exactly the laws of simple harmonic motion. This is because the real bond, though elastic, does not obey Hooke's law hence potential energy function will not be parabolic in nature. In order to obtain the experimentally observed spectra several potential energy functions have been suggested. One which was successful in its attempt was suggested by P.M. Morse and is called the Morse function and is given by

$$U = D_e [1 - \exp\{a(r_e - r)\}]^2 \quad \dots (3)$$

where D_e is called the dissociation energy and a is a constant for a particular molecule.

The idea of dissociation energy comes as follows. If the bond between atoms is stretched beyond a limit, there comes a point at which it will break - the molecule dissociates into atoms. This has also been incorporated in the potential energy function.

Put $r = \infty$ in the above equation, we get

$$U = D_e$$

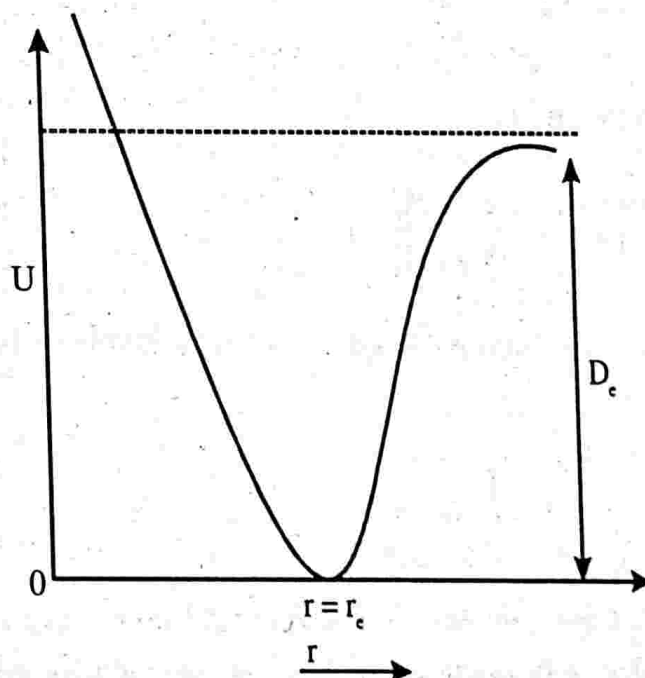

Figure 5.3

Hence the term dissociation energy. The graphical variation of U with r is given below.

From the equation, we get

$$r = r_e \text{ when } U = 0$$

when the two atoms are at equilibrium distance ($r = r_e$) the potential energy at equilibrium is zero, which is assumed.

Using the Morse function, solve the Schrodinger equation we get the vibrational energy levels as

$$\epsilon_v = \left(v + \frac{1}{2}\right) \bar{\nu}_e - \left(v + \frac{1}{2}\right)^2 \bar{\nu}_e x_e \quad (v = 0, 1, 2, \dots) \quad \dots (4)$$

where $\bar{\nu}_e$ is the equilibrium vibrational frequency of the oscillator expressed in wave numbers and x_e is the anharmonicity constant. The higher anharmonic terms are neglected. The first anharmonic term which is retained is small and positive for bond stretching vibrations. The effect of anharmonic term is to crowd more closely the vibrational levels. The energy levels are shown in figure.

Put $v = 0$ in the energy equation we get the zero point energy.

$$\text{i.e.,} \quad \epsilon_0 = \frac{1}{2} \bar{\nu}_e - \frac{1}{4} x_e \bar{\nu}_e$$

$$\text{or} \quad \epsilon_0 = \frac{1}{2} \left(1 - \frac{1}{2} x_e\right) \bar{\nu}_e$$

Rewriting equation (4) as

$$\epsilon_v = \left[1 - \left(v + \frac{1}{2}\right) x_e\right] \left(v + \frac{1}{2}\right) \bar{\nu}_e \quad \dots (5)$$

Comparing this equation with eqn (2) (energy levels of harmonic oscillator), we get.

$$\bar{\nu}_0 = \left[1 - \left(v + \frac{1}{2}\right) x_e\right] \bar{\nu}_e \quad \dots (6)$$

This shows that the anharmonic oscillator behaves like the harmonic oscillator but with an oscillation frequency which decreases steadily with increasing v .

The selection rules for the anharmonic oscillator are found to be

$$\Delta v = \pm 1, \pm 2, \pm 3$$

..... (7)

Normally only the lines of $\Delta v = \pm 1, \pm 2$ and ± 3 have observable intensity.

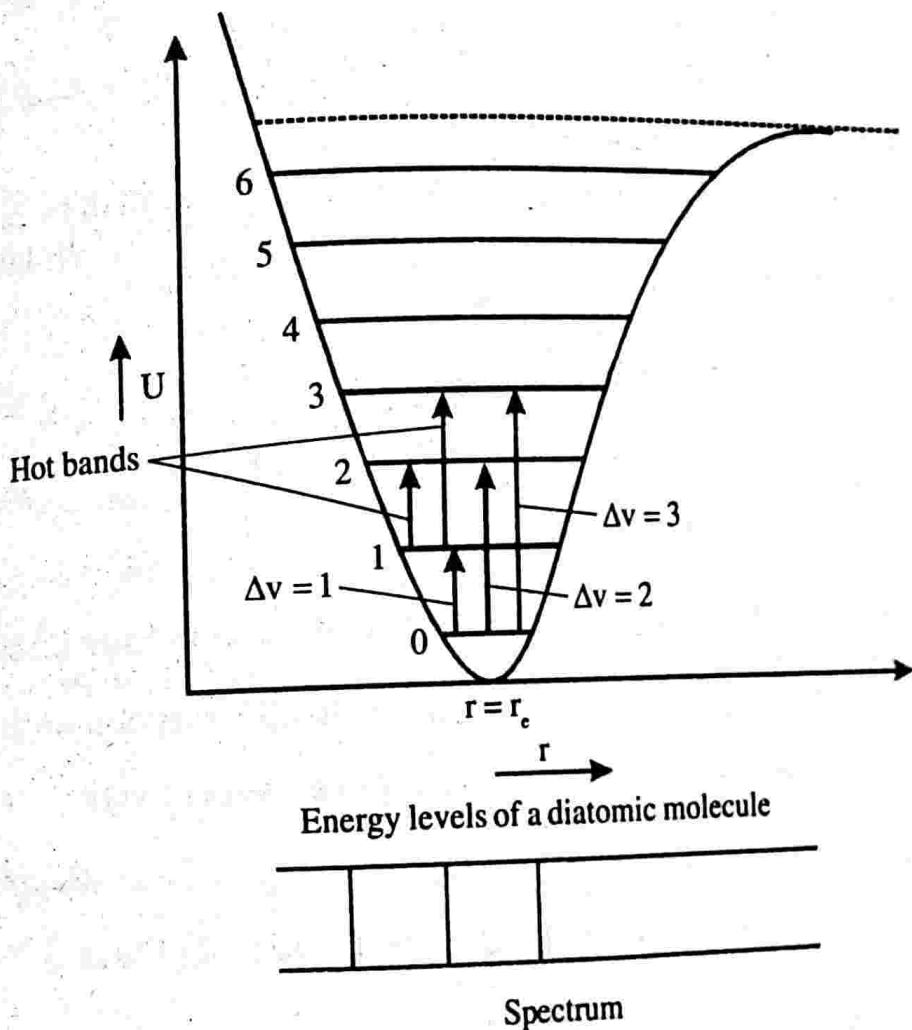

Figure : 5.4

At room temperature nearly all the molecules are in the $v = 0$ state. i.e., the molecules have only the zero point vibrational energy. The absorption of radiation must, therefore, result in transitions starting from $v = 0$.

1. The absorption band corresponds to $v = 0 \rightarrow v = 1$, $\Delta v = +1$, with considerable intensity.

$$\begin{aligned} \Delta \epsilon &= \epsilon_{v=1} - \epsilon_{v=0} = \left(1 + \frac{1}{2}\right) \bar{\nu}_e - \left(1 + \frac{1}{2}\right)^2 x_e \bar{\nu}_e - \left[\frac{1}{2} \bar{\nu}_e - \left(\frac{1}{2}\right)^2 x_e \bar{\nu}_e \right] \\ &= (1 - 2x_e) \bar{\nu}_e \end{aligned}$$

..... (8)

2. The absorption band corresponding to $v = 0 \rightarrow v = 2$, $\Delta v = +2$ with small intensity.

$$\begin{aligned}\Delta\varepsilon &= \varepsilon_{v=2} - \varepsilon_{v=0} = \left(2 + \frac{1}{2}\right)\bar{\nu}_e - \left(2 + \frac{1}{2}\right)^2 x_e \bar{\nu}_e - \left[\frac{\bar{\nu}_e}{2} - \left(\frac{1}{2}\right)^2 x_e \bar{\nu}_e\right] \\ &= 2(1 - 3x_e)\bar{\nu}_e\end{aligned}\quad \dots(9)$$

3. The absorption band corresponding to $v = 0 \rightarrow v = 3$, $\Delta v = +3$ with normally negligible intensity.

$$\begin{aligned}\Delta\varepsilon &= \varepsilon_{v=3} - \varepsilon_{v=0} = \left(3 + \frac{1}{2}\right)\bar{\nu}_e - \left(3 + \frac{1}{2}\right)^2 x_e \bar{\nu}_e - \left[\frac{\bar{\nu}_e}{2} - \left(\frac{1}{2}\right)^2 x_e \bar{\nu}_e\right] \\ &= 3(1 - 4x_e)\bar{\nu}_e\end{aligned}\quad \dots(10)$$

Since x_e is very small ($x_e \approx 0.01$), the above three absorption lines lie close to $\bar{\nu}_e$, $2\bar{\nu}_e$ and $3\bar{\nu}_e$. Thus the line near $\bar{\nu}_e$ is called fundamental absorption while those near $2\bar{\nu}_e$ and $3\bar{\nu}_e$ are called the first and second overtones respectively.

To cite an example, the spectrum of H^{35}Cl shows a very intense absorption at 2886cm^{-1} , a weaker one at 5668cm^{-1} and a very weak one at 8347cm^{-1} .

$$\text{i.e., } (1 - 2x_e)\bar{\nu}_e = 2886 \quad \dots(1)$$

$$2(1 - 3x_e)\bar{\nu}_e = 5668 \quad \dots(2)$$

$$3(1 - 4x_e)\bar{\nu}_e = 8347 \quad \dots(3)$$

Solving these we get the equilibrium frequency $\bar{\nu}_e$.

$$\text{eq (2) - eq (1) gives } \bar{\nu}_e - 4x_e \bar{\nu}_e = 2782 \quad \dots(4)$$

$$\text{eq (3) - eq (1) gives } \bar{\nu}_e - 6x_e \bar{\nu}_e = 2679 \quad \dots(5)$$

eq 4×6 - eq 5×4 gives

$$2\bar{\nu}_e = 5976$$

$$\bar{\nu}_e = 2988\text{cm}^{-1}$$

Put this in eq (1), we get

$$(1 - 2x_e)2988 = 2886$$

$$1 - 2x_e = \frac{2886}{2988} = 0.96586$$

$$2x_e = 1 - 0.96586$$

$$2x_e = 0.03414$$

$$x_e = 0.017$$

Using $\bar{\nu}_e$, we can directly calculate the force constant of HCl molecule.

$$\nu = \frac{1}{2\pi} \sqrt{\frac{k}{\mu}}$$

$$\text{or } \frac{\nu}{c} = \frac{1}{2\pi c} \sqrt{\frac{k}{\mu}} \qquad \frac{\nu}{c} = \frac{1}{\lambda} = \bar{\nu}_e$$

$$\bar{\nu}_e = \frac{1}{2\pi c} \sqrt{\frac{k}{\mu}}$$

Squaring on both sides we get

$$k = 4\pi^2 c^2 \mu \bar{\nu}_e^2$$

$$\therefore k = 4\pi^2 \times (3 \times 10^{10})^2 (2988)^2 \times 1.6261 \times 10^{-27}$$

$$\mu \text{ of HCl} = 1.6261 \times 10^{-27} \text{ kg}$$

$$\therefore k = 516 \text{ Nm}^{-1}$$

In the above discussion of transitions, we didn't consider the transition from $\nu = 1$ or $\nu =$ higher levels. At normal temperature these levels are empty. But if the temperature is raised or if the vibration has a low frequency, the population of state $\nu = 1$ becomes appreciable. The transitions from higher energy levels with the selection rule $\Delta\nu = 1$ are called hot bands. They are called hot bands since high temperature is one condition for their occurrence. The first hot band corresponds to

$$\nu = 1 \rightarrow \nu = 2; \Delta\nu = +1, \text{ normally very weak.}$$

$$\Delta\varepsilon = \varepsilon_{v=2} - \varepsilon_{v=1} = \left(2 + \frac{1}{2}\right)\bar{\nu}_e - \left(2 + \frac{1}{2}\right)^2 \bar{\nu}_e x_e - \left[\left(1 + \frac{1}{2}\right)\bar{\nu}_e - \left(1 + \frac{1}{2}\right)^2 \bar{\nu}_e x_e \right]$$

$$\Delta\varepsilon = (1 - 4x_e)\bar{\nu}_e \quad \dots (11)$$

Their nature may be confirmed by raising the temperature of the sample when a true hot band will increase in intensity.

Example 1

The fundamental and first overtone transitions of $^{14}\text{N}^{16}\text{O}$ are centred at 1876.06cm^{-1} and 3724.20cm^{-1} respectively. Evaluate the equilibrium vibration frequency, the anharmonicity and the exact zero point energy .

Solution

Given

$$(1 - 2x_e)\bar{\nu}_e = 1876.06 \quad \dots (1)$$

$$2(1 - 3x_e)\bar{\nu}_e = 3724.20 \quad \dots (2)$$

eq (1) \times 3 - eq (2) gives

$$\bar{\nu}_e = 1876.06 \times 3 - 3724.20$$

$$\bar{\nu}_e = 1903.98\text{cm}^{-1}$$

Putting the value of $\bar{\nu}_e$ in eq (1), we get

$$(1 - 2x_e) 1903.98 = 1876.06$$

$$1 - 2x_e = \frac{1876.06}{1903.98} = 0.98534$$

$$2x_e = 1 - 0.98534 = 0.01466$$

$$x_e = \frac{0.01466}{2} = 7.33 \times 10^{-3}$$

$$\text{Zero point energy } \varepsilon_0 = \frac{1}{2} \left(1 - \frac{1}{2} x_e \right) \bar{\nu}_e$$

$$\varepsilon_0 = \frac{1}{2} \left(1 - \frac{7.33 \times 10^{-3}}{2} \right) 1903.98$$

$$\varepsilon_0 = 948.5 \text{ cm}^{-1}$$

Example 2

The vibrational wave numbers of the following molecules in their $v=0$ states are HCl : 2885 cm^{-1} , DCl : 1990 cm^{-1} , D_2 : 2990 cm^{-1} and HD : 3627 cm^{-1} . Calculate the energy change in kJ mol^{-1} of the reaction.

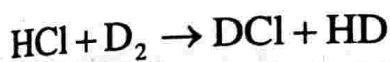

Solution

The zero point energy $\varepsilon_0 = \frac{1}{2} \bar{\nu}_e$

The zero point energy of (HCl + D_2)

$$= \frac{1}{2} (2885 + 2990) = 2937.5 \text{ cm}^{-1}$$

The zero point energy of (DCl + HD)

$$= \frac{1}{2} (1990 + 3627) = 2808.5 \text{ cm}^{-1}$$

$$\therefore \text{Energy released, } \varepsilon = 2937.5 - 2808.5 = 129 \text{ cm}^{-1}.$$

To convert this into joules multiply with hc

$$\begin{aligned} \therefore E &= hc \varepsilon = 6.626 \times 10^{-34} \times 3 \times 10^{10} \times 129 \\ &= 2564.26 \times 10^{-24} \text{ J} \end{aligned}$$

For one mole the energy released

$$\begin{aligned} E &= 2564.26 \times 10^{-24} \times 6.02 \times 10^{23} \text{ J} = 1.543 \times 10^3 \text{ J/mole} \\ &= 1.543 \text{ kJmole}^{-1} \end{aligned}$$

Infrared spectra-spectral transitions

A molecule is a collection of atoms. The atoms in a molecule execute different types of vibrational motion. The energy of most of these molecular vibrations is quantised and corresponds to that of the infrared region of the electromagnetic spectrum. When infrared radiation of the same frequency is allowed to fall on the molecule, the system absorbs energy causing the excitation of the molecule to higher vibrational levels. The molecules absorbing a quantum of energy give rise to bands characteristics of the molecule from about 50 to $12,500\text{cm}^{-1}$ approximately. This range is generally subdivided into three regions. $12500 - 4000\text{cm}^{-1}$ near IR region, $4000 - 400\text{cm}^{-1}$ middle IR region and $400 - 50\text{cm}^{-1}$ far IR region. The middle IR region is most important since it covers most of the vibrational transitions. The far IR region is important when we deal with solids.

Infrared selection rule

The transition from a vibrational state i to state j is determined by the probability of transition moment given by

$$\mu_{ij} = \int \psi_i^* \mu \psi_j d\tau$$

where ψ_i and ψ_j are the wave functions for the vibrational states i and j and μ is the dipole moment operator. The dipole moment of a molecule is a function of normal coordinates Q_k of the vibrational and can be expanded in a Taylor series.

$$\mu = \mu_0 + \left(\frac{\partial \mu}{\partial Q_k} \right)_0 Q_k + \dots$$

Neglected higher order terms.

$$\therefore \mu_{ij} = \int \psi_i^* \left[\mu_0 + \left(\frac{\partial \mu}{\partial Q_k} \right)_0 Q_k \right] \psi_j d\tau$$

$$\mu_{ij} = \mu_0 \int \psi_i^* \psi_j d\tau + \left(\frac{\partial \mu}{\partial Q_k} \right)_0 \int \psi_i^* Q_k \psi_j d\tau$$

$$\int \psi_i^* \psi_j d\tau = 0 \text{ orthogonality condition.}$$

$$\therefore \mu_{ij} = \left(\frac{\partial \mu}{\partial Q_K} \right)_0 \int \psi_i^* Q_K \psi_j d\tau$$

For the transition to occur the probability of transition moment μ_{ij} must be non zero. For this to occur

1. $\left(\frac{\partial \mu}{\partial Q_K} \right)_0 \neq 0$ and

2. $\int \psi_i^* Q_K \psi_j d\tau \neq 0$

Condition (1) says that at least one component of μ must exist and there must be a change in the dipole moment. Condition (2) says that the integral must be finite. This is possible only if the vibrational quantum number changes by $\Delta v = \pm 1$ under harmonic oscillator and $\Delta v = \pm 1, \pm 2, \pm 3, \dots$ for anharmonic oscillator.

Diatomic vibrating rotator

So far we have considered rotation and vibration of a diatomic molecule separately. But in reality a diatomic molecule possesses both the motion simultaneously. i.e., a molecule rotates while executing vibrational motion and therefore rotational energy changes may also accompany vibrational energy change. As a result we obtain a complex spectra which reflects both rotational and vibrational energy changes. Since the energies of two motions differ considerably, as a first approximation we consider that a diatomic molecule can execute rotations and vibrations quite independently. This is called the Born - Oppenheimer approximation.

The total energy of the diatomic molecule is given by

$$\epsilon_{\text{total}} = \epsilon_{\text{rot}} + \epsilon_{\text{vib}}$$

i.e., $\epsilon_{\text{total}} = \epsilon_J + \epsilon_v$ in cm^{-1} .

$$\epsilon_{\text{total}} = \epsilon_{Jv} = BJ(J+1) - DJ^2(J+1)^2 + \left(v + \frac{1}{2} \right) \bar{\nu}_e - \left(v + \frac{1}{2} \right)^2 x_e \bar{\nu}_e$$

where $J = 0, 1, 2, \dots$ and $v = 0, 1, 2, \dots$

The selection rule for the combined motions are the same for separate motions

i.e., $\Delta J = \pm 1$ and $\Delta v = \pm 1, \pm 2, \pm 3, \dots$

Now consider the vibrational transition $v = 0 \rightarrow v = 1$. Denoting the upper state by J' and lower state by J'' and assume that Band D are the same for both.

$$\begin{aligned} \therefore \Delta \epsilon_{J',v} = \epsilon_{J',v=1} - \epsilon_{J',v=0} &= B[J'(J'+1) - J''(J''+1)] - D[J'^2(J'+1)^2 - J''^2(J''+1)^2] \\ &+ \left[\left(1 + \frac{1}{2}\right) \bar{\nu}_e - \left(1 + \frac{1}{2}\right)^2 x_e \bar{\nu}_e \right] - \left[\frac{1}{2} \bar{\nu}_e - \left(\frac{1}{2}\right)^2 x_e \bar{\nu}_e \right] \end{aligned}$$

Using the selection rule $\Delta J = 1 = J' - J''$

Replace all J' with $1 + J''$, we get

$$\Delta \epsilon_{J',v} = B[(1 + J'')(1 + J'' + 1) - J''(J'' + 1)]$$

$$- D[(1 + J'')^2 (1 + J'' + 1)^2 - J''^2 (J'' + 1)^2]$$

$$+ \frac{3}{2} \bar{\nu}_e - \frac{9}{4} x_e \bar{\nu}_e - \frac{1}{2} \bar{\nu}_e + \frac{1}{4} x_e \bar{\nu}_e$$

$$\Delta \epsilon_{J',v} = B[(1 + J'')(2 + J'') - J''(J'' + 1)]$$

$$- D\left\{ (1 + J'')^2 [(2 + J'')^2 - J''^2] \right\} + \bar{\nu}_e - 2x_e \bar{\nu}_e$$

$$\Delta \epsilon_{J',v} = B[(2 + J'' + 2J'' + J''^2 - J''^2 - J'')]$$

$$- D(1 + J'')^2 [4 + 4J'' + J''^2 - J''^2] + \bar{\nu}_e (1 - 2x_e)$$

$$\Delta \epsilon_{J',v} = B2(J'' + 1) - 4D(1 + J'')^3 + \bar{\nu}_e (1 - 2x_e)$$

The term $(1 - 2x_e)\bar{\nu}_e$ can be recognised to be the frequency of transition from $v = 0 \rightarrow v = 1$ and is denoted by $\bar{\nu}_0$.

$$\therefore \Delta \epsilon_{J',v} = \bar{\nu}_0 + 2B(J'' + 1) - 4D(1 + J'')^3 \text{ with } J'' = 0, 1, 2 \quad \dots (12)$$

Similarly for the selection rule $\Delta J = -1$ i.e., $J' - J'' = -1$ we get

$$\Delta \epsilon_{J',v} = \bar{\nu}_0 - 2B(J' + 1) + 4D(1 + J')^3 \text{ with } J' = 0, 1, 2 \quad \dots (13)$$

Lines corresponding to $\Delta J = -1$ are called the P branch and those corresponding to $\Delta J = +1$ are referred to as R branch.

Lines arising from $\Delta J = -2, -1, 0, +1, +2$ are called O, P, Q, R and S branch respectively.

Combining equations 12 and 13 by replacing $J'' + 1$, with m in eqn 12 and $J' + 1$ with m in eqn 13, we get.

$$\Delta \epsilon_{J,v} = \bar{\nu}_0 + 2Bm - 4Dm^3, \quad m = \pm 1, \pm 2, \pm 3, \dots \quad \dots (14)$$

m takes positive values for $\Delta J = \pm 1$ and negative values for $\Delta J = -1$.

Note that m cannot be zero because if $m = 0$ then $J'' + 1 = 0$ or $J' + 1 = 0$ which implies that $J'' = -1$ or $J' = -1$, This is not allowed. The frequency $\bar{\nu}_0$ is usually called the band origin or band centre.

Usually the value of D is very small. This is because the value of B is about 10cm^{-1} or less, while D is only nearly 1% of B . Since a good infrared spectrometer has a resolving power of about 0.5cm^{-1} it is obvious that D is negligibly small. In such cases equation 14 becomes.

$$\Delta \epsilon_{J,v} = \bar{\nu}_0 + 2Bm \text{ cm}^{-1} \quad \dots (15)$$

This represents the combined vibration rotation spectrum. Such a spectrum will obviously consist of equally spaced lines with a spacing $2B$ on each side of $\bar{\nu}_0$. Since $m \neq 0$, the line at $\bar{\nu}_0$ itself will not appear. If $m \neq 0$, we get $\Delta \epsilon_{J,v} = \bar{\nu}_0$ so we can expect a spectral line. But $m = 0$ is forbidden, because $m = 0$ implies $J'' = -1$ or $J' = -1$ this is not allowed. So $m = 0$ is not allowed. Hence we cannot get spectral lines of $\bar{\nu}_0$.

If we consider a spectrum corresponding to transition from $v = 0 \rightarrow v = 1$, we get two branches (P branch and R branch) on either side of the unseen spectral line corresponding to $\bar{\nu}_0$. P branch corresponds to $\Delta J = -1$ and R branch corresponds to $\Delta J = +1$. See figure below.

These theoretical predictions are in agreement with the experiment.

Further more analysis of the vibration-rotation spectrum of a diatomic molecule allows us one to determine the band $\bar{\nu}_0$ and B from the spacing between the lines. From B , one can calculate the bond length and from $\bar{\nu}_0$ the bond force constant.

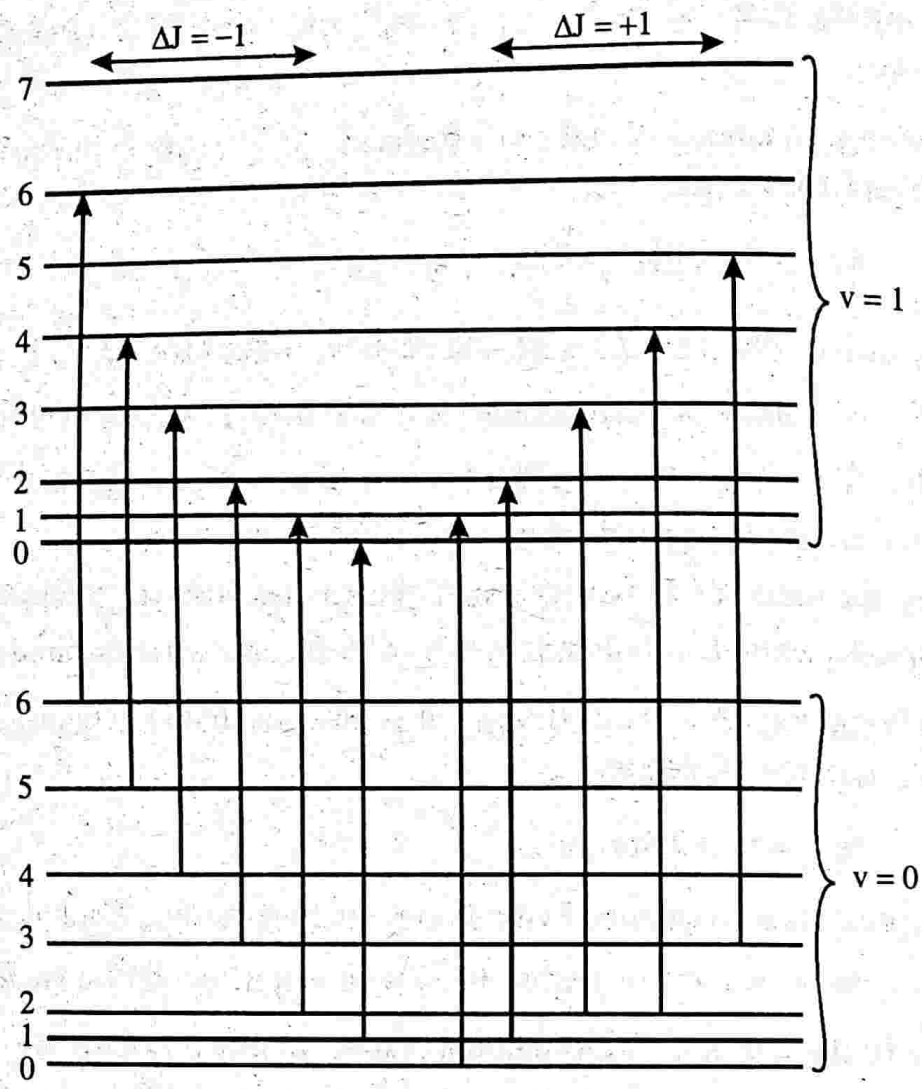

Rotational energy levels of the vibrational states $v = 0 \rightarrow v = 1$

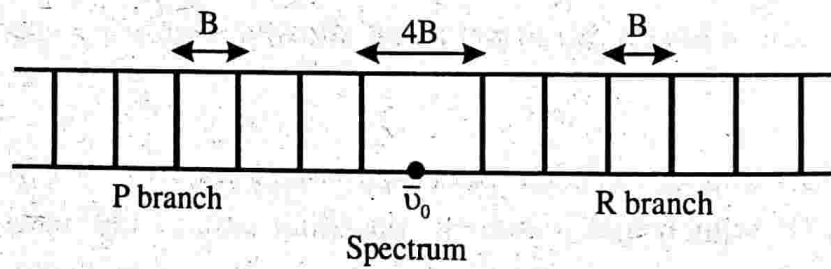

Figure 5.5

Note: - we have $\Delta\epsilon_{J,v} = \bar{\nu}_0 + 2Bm$ when $m = -1$, which corresponds to first P line.

i.e.,
$$\Delta\epsilon_{Jv}^{P_1} = \bar{\nu}_0 - 2B$$

when $m = +1$, which corresponds to first R line

i.e.,
$$\Delta\epsilon_{Jv}^{R_1} = \bar{\nu}_0 + 2B$$

∴ Separation between first R line and first P line on either side of the $\bar{\nu}_0$ line is

$$\Delta\varepsilon_{Jv}^R - \varepsilon_{Jv}^P = (\bar{\nu}_0 + 2B) - (\bar{\nu}_0 - 2B) = 4B$$

Similarly for $m = -2$, which corresponds 2nd P line

i.e.,
$$\Delta\varepsilon_{Jv}^{R_2} = \bar{\nu}_0 - 4B$$

∴
$$\Delta\varepsilon_{Jv}^{P_1} - \Delta\varepsilon_{Jv}^{R_2} = (\bar{\nu}_0 - 2B) - (\bar{\nu}_0 - 4B) = 2B$$

When $m = 2$, which correspond to 2nd R line.

$$\Delta\varepsilon_{Jv}^{R_2} = \bar{\nu}_0 + 4B$$

∴
$$\Delta\varepsilon_{Jv}^{R_2} - \Delta\varepsilon_{Jv}^{R_1} = (\bar{\nu}_0 + 4B) - (\bar{\nu}_0 + 2B) = 2B$$

It shows that the spacing between any two adjacent P line or R line is 2B.

Example 3

The fundamental band for HCl is centred at 2886cm^{-1} . Assuming that the inter nuclear distance is 1.276\AA . Calculate the wave number of the first two lines of each P and R branches of HCl.

Solution

$$\bar{\nu}_0 = 2886\text{cm}^{-1}$$

$$r = 1.276\text{\AA} = 1.277 \times 10^{-10}\text{m}$$

$$\begin{aligned} \mu \text{ of HCl} &= \frac{m_{\text{H}} \times m_{\text{Cl}}}{m_{\text{H}} + m_{\text{Cl}}} = \frac{1.008 \times 35.45}{(1.008 + 35.45)} 6.023 \times 10^{26} \\ &= 1.6275 \times 10^{-27}\text{kg} \end{aligned}$$

$$\text{The rotational constant } B = \frac{h}{8\pi^2 \mu r^2 c}$$

$$B = \frac{6.626 \times 10^{-34}}{8 \times \pi^2 \times 1.6275 \times 10^{-27} \times (1.276 \times 10^{-10})^2 \times 3 \times 10^{10}}$$

$$B = 10.6129\text{cm}^{-1}$$

Using

$$(\Delta\varepsilon)_{Jv} = \bar{\nu}_0 + 2Bm$$

$$(\Delta\varepsilon)_{Jv}^{P_1} = \bar{\nu}_0 - 2B = 2886 - 2 \times 10.6129 = 2864.79\text{cm}^{-1}$$

$$(\Delta\varepsilon)_{J,v}^{P_2} = \bar{\nu}_0 - 4B = 2886 - 4 \times 10.6129 = 2843.55 \text{ cm}^{-1}$$

$$(\Delta\varepsilon)_{J,v}^{R_1} = \bar{\nu}_0 + 2B = 2886 + 6 + 2 \times 10.6129 = 2907.23 \text{ cm}^{-1}$$

$$(\Delta\varepsilon)_{J,v}^{R_2} = \bar{\nu}_0 + 4B = 2886 + 6 + 4 \times 10.6129 = 2928.45 \text{ cm}^{-1}.$$

Example 4

Calculate the energy in cm^{-1} of the absorbed when HCl molecule goes from the state $v=0, J''=1 \rightarrow v=1, J'=0$ and $v=0, J''=1 \rightarrow v=1, J'=2$. Given $\bar{\nu}_e = 2990 \text{ cm}^{-1}$, $x_e = 0.0174$, $r_{\text{HCl}} = 0.1274 \text{ nm}$ and $\mu_{\text{HCl}} = 1.6275 \times 10^{-27} \text{ kg}$.

Solution

$v=0, J''=1 \rightarrow v=1, J'=0$ corresponds to the first line in the P branch

$$\text{So } (\Delta\varepsilon)_{J,v} = (1 - 2x_e)\bar{\nu}_e - 2B$$

$$\text{But } B = \frac{h}{8\pi^2 \mu r^2 c} = \frac{6.626 \times 10^{-34}}{8\pi^2 \times 1.6275 \times 10^{-27} \times (0.1274 \times 10^{-9})^2 \times 3 \times 10^{10}}$$

$$B = 10.589 \text{ cm}^{-1}$$

$$\begin{aligned} \therefore (\Delta\varepsilon)_{J,v}^P &= (1 - 2 \times 0.0174)2990 - 2 \times 10.589 \\ &= 2885.95 - 21.178 \\ &= 2864.77 \text{ cm}^{-1}. \end{aligned}$$

$v=0, J''=1 \rightarrow v=1, J'=2$ corresponds to the second line in the R branch
($m=2$)

$$\begin{aligned} \therefore (\Delta\varepsilon)_{J,v}^{R_1} &= (1 - 2x_e)\bar{\nu}_e + 4B \\ &= 2885.95 + 42.356 \\ &= 2928 \text{ cm}^{-1}. \end{aligned}$$

IMPORTANT FORMULAE

1. Harmonic oscillator model:

a) Restoring force: $f = -k(r - r_e)$

b) Potential energy: $U = \frac{1}{2}k(r - r_e)^2$

c) Frequency of the oscillator: $\nu = \frac{1}{2\pi} \sqrt{\frac{k}{\mu}}$ $\mu = \frac{m_1 m_2}{m_1 + m_2}$

2. The vibrational energy of oscillator:

$$E_v = \left(v + \frac{1}{2} \right) h\nu_0, \quad v = 0, 1, 2, 3, \dots$$

or
$$\epsilon_v = \left(v + \frac{1}{2} \right) \frac{\nu_0}{c}$$

$$\epsilon_v = \left(v + \frac{1}{2} \right) \bar{\nu}_0, \quad \bar{\nu}_0 = \frac{1}{\lambda} = \frac{\nu_0}{c}$$

 3. Selection rule for harmonic oscillator system: $\Delta v = \pm 1$

4. Morse function:

$$U = D_e \left[1 - e^{-a(r_e - r)} \right]^2$$

5. Vibrational energy levels of an anharmonic oscillator using Morse function:

$$\epsilon_v = \left(v + \frac{1}{2} \right) \bar{\nu}_e - \left(v + \frac{1}{2} \right)^2 \bar{\nu}_e x_e$$

6. Selection rules for the anharmonic oscillator:

$$\Delta v = \pm 1, \pm 2, \pm 3$$

7. Rotational-vibrational energy of a diatomic molecule:

$$\epsilon_{\text{total}} = BJ(J+1) - DJ^2(J+1)^2 + \left(v + \frac{1}{2} \right) \bar{\nu}_e - \left(v + \frac{1}{2} \right)^2 x_e \bar{\nu}_e$$

8. Selection rule for the combined (rotational and vibrational) motions:

$$\Delta J = \pm 1 \quad \text{and} \quad \Delta v = \pm 1, \pm 2, \pm 3$$

9. The spacing between any two adjacent P-lines or R lines = 2B.

UNIVERSITY MODEL QUESTIONS

Section A

*(Answer questions in two or three sentences)***Short answer type questions**

1. What is infrared spectroscopy?
2. What is vibrational spectra?
3. What is zero point energy? What is its significance?
4. What is rotational quantum number?
5. Write down the selection rule for the harmonic oscillator under going vibrational changes.
6. Write down the expression for the vibrational energy of a harmonic oscillator system and explain the symbols.
7. Draw the allowed vibrational energy levels and transitions between them for a diatomic molecule undergoing simple harmonic motion.
8. Homonuclear diatomic molecules donot show vibrational spectra. Why?
9. Real molecules donot obey exactly the laws of simple harmonic motion. Why?
10. Explain the diatomic molecule as a simple harmonic oscillator model.
11. What is an anharmonic oscillator?
12. What is Morse function?
13. Draw graphical representation of Morse function.
14. Write down the expression for energy eigen value of a diatomic molecule as an anharmonic oscillator.
15. Write down the selection rules for the anharmonic oscillator.
16. What is fundamental absorption of an anharmonic oscillator?
17. What are first and second overtones of absorption of a anharmonic oscillator?
18. What are hot bands? Why are they called so?
19. Explain the formation of IR spectra.
20. What are the selection rules for the infrared spectra?
21. What is Born Oppenheimer approximation?
22. Write down the expression for total energy of a diatomic molecule as a vibrating rotator in terms of wave number and explain the symbols.
23. Explain the P-branch and R branch of a rotation vibration spectrum.
24. Show that the spacing between any two adjacement P lines or R lines is equal to B.
25. Write down the expression for the separation between two maxima of the branches.
26. What are the selection rules for the rotation-vibration spectra.
27. Draw the rotational energy levels of the vibrational states $v = 0 \rightarrow v = 1$.

Section B

(Answer questions in a paragraph of about half a page to one page)

Paragraph / Problem type questions

- Show that the spacing of vibrational energy levels of a diatomic molecule as a harmonic oscillator are equally spaced.
- The fundamental and first overtone transitions of CO are centred at 2143.3 cm^{-1} and 4260.0 cm^{-1} . Calculate the equilibrium oscillation frequency, the anharmonicity constant and force constant of the molecule.

$$[\bar{\nu}_e = 2170 \text{ cm}^{-1}, x_e = 0.006124, k = 1905 \text{ Nm}^{-1}]$$
- The fundamental vibration frequency of HCl is 2989 cm^{-1} . Find the force constant of HCl bond.

$$[516.9 \text{ Nm}^{-1}]$$
- The vibration frequency of $^1\text{H}^{35}\text{Cl}$ is 2990.6 cm^{-1} without calculating the bond constant estimate the frequency of $^1\text{H}^{37}\text{Cl}$ and $^2\text{D}^{35}\text{Cl}$.

$$[2988 \text{ cm}^{-1}, 2144 \text{ cm}^{-1}]$$
- The mean intermolecular distance for HCl in the $v = 0$ and $v = 1$ level is 1.293 \AA . Calculate the difference in cm^{-1} between the first P line and the first R line in the rotation - vibration spectrum. Given μ of HCl = $1.6275 \times 10^{-27} \text{ kg}$.

$$[41.12 \text{ cm}^{-1}]$$
- Calculate the energy in cm^{-1} of the photon absorbed when NO molecule goes from the state $v = 0, J'' = 0 \rightarrow v = 1, J' = 1$. Assume that the $v = 0$ and $v = 1$ states have the same B values. Given $\bar{\nu}_e = 1904 \text{ cm}^{-1}$, $x_e = 0.00733$, $r_{\text{NO}} = 0.1151 \text{ nm}$ and $\mu_{\text{NO}} = 12.3975 \times 10^{-27} \text{ kg}$.

$$[1879.49 \text{ cm}^{-1}]$$
- The frequency of OH vibration in CH_3OH is 3300 cm^{-1} . Estimate the frequency of OD stretching vibration in CH_3OD .

$$[2401 \text{ cm}^{-1}]$$

Section C

(Answer questions in about two pages)

Long answer type questions (Essays)

- Discuss the theory of rotation-vibration spectrum of a diatomic molecule.
- Discuss the rotational spectra of a diatomic molecule as a (a) harmonic oscillator (b) anharmonic oscillator.

Hints to problems

$$2. (1 - 2x_e)\bar{\nu}_e = 2143.3 \quad \dots (1)$$

$$2(1 - 3x_e)\bar{\nu}_e = 4260.0 \quad \dots (2)$$

$$\frac{\text{eqn 2}}{\text{eqn 1}} \rightarrow \frac{2(1 - 3x_e)}{(1 - 2x_e)} = \frac{4260}{2143.3} = 1.9876$$

$$\text{or } 2 - 6x_e = 1.9876 - 1.9876 \times 2x_e$$

$$2 - 1.9876 = 6x_e - 1.9876 \times 2x_e$$

$$0.0124 = 2.0248x_e$$

$$\therefore x_e = \frac{0.0124}{2.0248} = 6.124 \times 10^{-3}$$

Put this value in eqn (1), we get $\bar{\nu}_e = 2170 \text{ cm}^{-1}$

Force constant, $k = 4\pi^2 c^2 \mu \bar{\nu}_e^2$

$$\mu \text{ of CO} = \frac{m_C \times m_O}{m_C + m_O} = \frac{12 \times 15.9994}{(12 + 15.9994) \times 6.02 \times 10^{26}} = 1.1385 \times 10^{-26} \text{ kg}$$

$$\therefore k = 1904.8 \approx 1905 \text{ Nm}^{-1}$$

3. Using $k = 4\pi^2 c^2 \mu \bar{\nu}_e^2$, $\nu_e = 2989 \text{ cm}^{-1}$

$$\begin{aligned} \mu \text{ of HCl} &= \frac{m_H \times m_{Cl}}{m_H + m_{Cl}} = \frac{1.673 \times 10^{-27} \times 61.38 \times 10^{-27}}{(1.673 + 61.38) \times 10^{-27}} \\ &= 1.6286 \times 10^{-27} \text{ kg} \end{aligned}$$

$$\therefore k = 516.9 \text{ Nm}^{-1}$$

4. We have $\bar{\nu}_e = \frac{1}{2\pi} \sqrt{\frac{k}{\mu}}$

$$\text{or } \bar{\nu}_e \propto \frac{1}{\sqrt{\mu}}$$

$$\therefore \frac{(\bar{\nu}_e)_{H^{37}Cl}}{(\bar{\nu}_e)_{H^{35}Cl}} = \sqrt{\frac{\mu_{35}}{\mu_{37}}} = \sqrt{\frac{m_H \times {}^{35}m_{Cl}}{m_H + {}^{35}m_{Cl}} \times \frac{m_H + {}^{37}m_{Cl}}{m_H \times {}^{37}m_{Cl}}} = \sqrt{\frac{35}{36} \times \frac{38}{37}} = 0.9992$$

$$\begin{aligned} \therefore (\bar{\nu}_e)_{H^{37}Cl} &= 0.9992 \times 2990.6 \\ &= 2987.9 \approx 2988 \text{ cm}^{-1} \end{aligned}$$

Similarly the other one

5. Using $B = \frac{h}{8\pi^2 \mu r^2 c}$

Put $c = 3 \times 10^{10} \text{ cms}^{-1}$ so B will be in cm^{-1} .

We get $B = 10.28 \text{ cm}^{-1}$ our requirement is $4B$.

6. The transition $v = 0, J'' = 0 \rightarrow v = 1, J' = 1$ corresponds to the first line in the R branch.

$$\Delta \varepsilon = (1 - 2x_e) \bar{\nu}_e + 2B$$

$$\text{where } B = \frac{h}{8\pi^2 \mu r^2 c}$$

7. $\bar{\nu} \propto \sqrt{\mu}$

$$\therefore \frac{\bar{\nu}_{\text{OD}}}{\bar{\nu}_{\text{OH}}} = \sqrt{\frac{\mu_{\text{OD}}}{\mu_{\text{OH}}}} = \sqrt{\frac{16 \times 2}{16 + 2} \times \frac{16 + 1}{16 \times 1}} = 1.3744$$

$$\therefore \bar{\nu}_{\text{OD}} = 1.3744 \bar{\nu}_{\text{OH}}$$

6

PHOTONICS

Introduction

Laser is the acronym for Light Amplification by Stimulated Emission of Radiation.

Laser is one of the outstanding inventions of the second half of the last century. Laser is a light source but it is very much different from many of traditional light sources. Laser is a photonic device to produce intense, monochromatic, coherent and unidirectional beam of light. Lasers are in fact generators of light. They are based on the amplification of light by means of stimulated emission of radiation of atoms or molecules. In 1917 Einstein predicted the possibility of such stimulated radiation.

In 1952 Townes, Gordon and Zeiger in U.S.A. and Basov and Prokhorov in USSR independently suggested the principle of generating and amplifying microwave oscillations based on the concept of stimulated radiation. It led to the invention of MASER (Microwave Amplification by Stimulated Emission of Radiation) in 1954. In 1958 Townes and Schawlow and Basov and Prokhorov independently expressed their ideas about extending the maser concept to optical frequencies which led to the invention of laser. Townes, Basov and Prokhorov both received Nobel prizes for their work in this field. In 1960 Theodore Maiman of Hughes Research Laboratories (HRL) fabricated the first laser using a ruby crystal as the amplifier and a flash lamp as the energy source. After this a series of lasers were discovered.

It is due to the characteristics of lasers such as extreme brightness (intensity), monochromaticity, high directionality and coherence, they have wide applications in different areas. The laser is used in metal working such as welding and piercing holes in metals. Lasers are used as saw to cut thick metal sheets, as a phonograph needle for compact discs, as a knife during surgical operations (bloodless surgery). They are used in optical communications, weapon guidance in wars, detecting and ranging objects at greater distance; in holography and in a wide variety of other fields. The discovery of laser and its technological applications gave birth to a new field namely photonics.

Quantum behaviour of light (preliminary ideas)

In 1900, Max Planck proposed that light consists of discrete bundles of energy.

The amount of energy of each bundle is $h\nu$. These bundles of radiant energy are called quanta. In 1905 Einstein refined the quantum hypothesis of Planck by introducing photon concept. A photon represents the minimum energy unit of light. Each photon carries an amount of energy proportional to the frequency of the light wave, as given by

$$E = h\nu$$

where h is Planck's constant. It is obvious that the higher the frequency of a photon, the more the energy it possesses. Thus UV light photons are more energetic than visible light photons. The light energy E emitted by a source must be an integral multiples of the photon energy. Thus

$$E = nh\nu, \text{ where } n = 1, 2, 3, \dots$$

Absorption and emission of light

In an atom, an electron in the ground state is stable and moves continuously in that orbit without radiating energy. When the electron receives an amount of energy equal to the difference of energy of the ground state and one of the excited states, it absorbs energy and jumps to the excited state. There are variety of ways in which the energy may be supplied to the electron. One way is to illuminate the material with

light of appropriate frequency $\nu = \frac{E_2 - E_1}{h}$. The photons of energy $h\nu = E_2 - E_1$ induce electron transition from the energy level E_1 to the level E_2 as shown in figure.

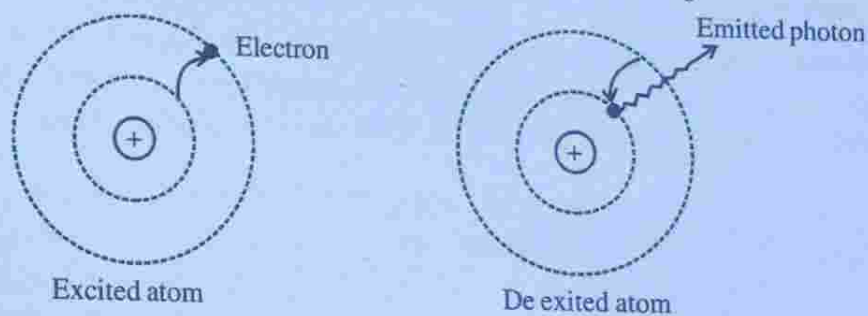

Figure 6.1

However, the electron cannot stay in the excited state for a longer time. The coulomb attraction due to the positive nucleus pulls the electron back to the initial inner orbit and the electron returns to the ground state. The excited electron has excess energy equal to $E_2 - E_1$ and it has to get rid of this energy in order to come to the lower energy level. The only mechanism through which the electron can lose its excess energy is through the emission of a photon. Therefore, the excited electron emits a photon of energy $h\nu = E_2 - E_1$ and returns to the ground state.

When we see light from any source we actually see electrons jumping from excited states to lower states. This type of emission of light which occurs on its own is known as spontaneous emission and is responsible for the light coming from candles, electric bulbs, fire, stars, sun etc. conventional sources of light.

Population

The atoms of each chemical element have their own characteristic system of energy levels. The energy difference between the successive energy levels of an atom is of the order of 1eV to 5eV. The energy levels are common to all the atoms in a system which is composed of identical atoms. We can therefore say that a certain number of atoms occupy a given energy state. The number of atoms per unit volume that occupy a given energy state is called the population of that energy state. The population N of an energy level E depends on the temperature and is given by

$$N = e^{-\frac{E}{kT}} \quad \dots\dots (1)$$

where k is known as Boltzmann's constant.

This is called Boltzmann's equation.

In a material, atoms are distributed differently in different energy states. The atoms normally tend to be at their lowest possible energy level which need not be the ground state. At temperatures above 0K, the atoms always have some thermal energy and therefore, they are distributed among the available energy levels according to their energy.

At thermal equilibrium, the number of atoms at each energy level decreases with increase of energy level. If we consider two energy levels E_1 and E_2 their populations can be computed with the help of Boltzmann's equation. Thus

$$N_1 = e^{-\frac{E_1}{kT}}$$

and
$$N_2 = e^{-\frac{E_2}{kT}}$$

$$\therefore \frac{N_2}{N_1} = e^{-\frac{(E_2 - E_1)}{kT}} \quad \dots\dots (2)$$

$\frac{N_2}{N_1}$ is called relative population.

As an example let us calculate the atomic population of hydrogen gas at room temperature at 300K at the first excited level.

Here $E_1 = -13.6\text{eV}$, $E_2 = -3.39\text{eV}$
and $T = 300\text{K}$.

$$E_2 - E_1 = -3.39 - (-13.6) = 10.21\text{eV}$$

$$kT = 8.6 \times 10^{-5} \frac{\text{eV}}{\text{K}} \cdot 300\text{K} = 0.025\text{eV}$$

$$\therefore \frac{N_2}{N_1} = e^{-\frac{10.21}{0.025}} = e^{-408.4} \approx 0$$

It shows that at room temperature all atoms are in the ground state. If temperature is raised to 6000 K

$$\frac{N_2}{N_1} = e^{-\frac{10.21}{0.516}} = e^{-19.79} = 2.5 \times 10^{-9}$$

It shows that in a material at thermal equilibrium more atoms are in the lower energy state. We call such a distribution of atoms as normal distribution.

Einstein's prediction of stimulated emission

Einstein predicted in 1917 there must be a second emission process to establish thermodynamic equilibrium. For example if we illuminate a material with light of suitable frequency the atoms in it absorb light and go to higher energy states. The excited atoms tend to return randomly to the lower energy state. As the ground state population is very large, more and more atoms are excited under the action of incident light and it is likely that a stage may be reached where all atoms are excited. This violates thermal equilibrium condition. Therefore, Einstein suggested that there could be additional emission mechanism by which the excited atoms can make downward transitions. He predicted that the photons in the light field induce the excited atoms to fall to lower energy states and give up their excess energy in the form of photons. He called this second type of emission as stimulated emission.

Interaction of light with matter

According to classical physics the process of transfer of energy from atom to light is not possible. But this is possible from the point of view of quantum mechanics. The transfer of energy from atom to light results in the light amplification. A light amplifier can be further converted into a source of light having superior characteristics compared to traditional light sources. This superior characteristic light source formed due to the transfer of energy from atom to light which is amplified is

termed as laser. In order to understand the development of laser we have go for the quantum mechanical treatment.

We know that the radiation incident on a material is a stream of photons according to quantum theory and each photon carries an energy $E = h\nu$. We assume that two energy levels of the atoms in the material have an energy difference, $E_2 - E_1 = h\nu$. When photons travels through material medium three different process are likely to occur. They are absorption, spontaneous emission and stimulated emission. We study these in detail.

Absorption

Induced absorption

Suppose an atom is in the lower energy level E_1 . If a photon of energy $h\nu = E_2 - E_1$, is incident on the atom, photons gives its energy to the atom and disappears. Then we say that the atom absorbed an incident photon. As a result of this absorption the atom jumps to the excited state E_2 . This process is called induced absorption. This process may be represented as

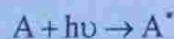

where A denotes an atom in the lower state and A^* an excited atom.

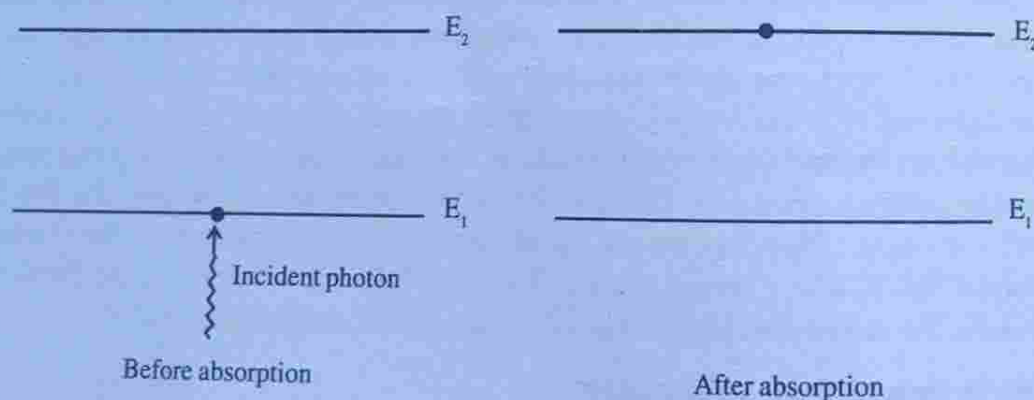

Figure 6.2

The number of atoms per unit volume that makes upward transitions from the lower level to the upper level per second is called the rate of absorption transition. It is represented by

$$R_{\text{abs}} = -\frac{dN_1}{dt}$$

where $-\frac{dN_1}{dt}$ stands for the rate of decrease of population at the lower level. The rate of absorption transition can also be represented by the rate of the increase of population at the upper level E_2 . Thus

$$R_{\text{abs}} = \frac{dN_2}{dt}$$

$$\therefore R_{\text{abs}} = -\frac{dN_1}{dt} = \frac{dN_2}{dt}$$

The number of absorption transitions occurring in the material at any instant will be proportional to the population in the lower level and the number of photons per unit volume in the incident beam. The rate of absorption may be expressed as

$$R_{\text{abs}} = B_{12} u(\nu) N_1$$

where B_{12} is a constant of proportionality and $u(\nu)$ is the energy density of incident light. B_{12} is known as the Einstein's coefficient for induced absorption and it indicates the probability of induced transition from level 1 to 2.

It may be noted that at thermal equilibrium, the population in the lower energy state is far larger than in the higher energy state. Therefore, as light propagates through the medium, it gets absorbed

Spontaneous emission

An atom cannot stay in the excited state for a long time. In about 10^{-8} s, the atom comes back to the lower state E_1 by releasing a photon of energy $h\nu = E_2 - E_1$. This emission of photon occurs on its own and without any external impetus given to the excited atom is called spontaneous emission. This process is represented as

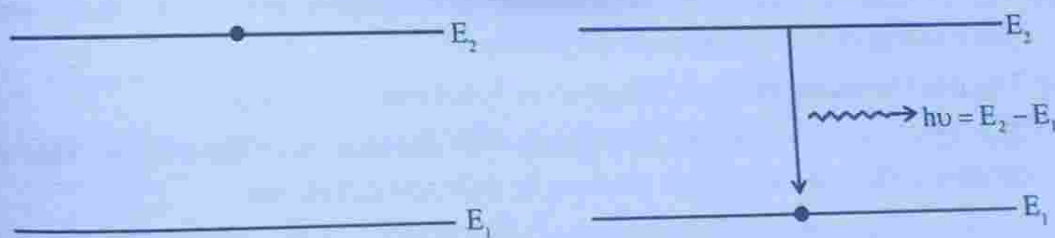

Figure 6.3

The rate of spontaneous transitions R_{sp} is given by

$$R_{sp} = -\frac{dN_2}{dt} = \frac{N_2}{\tau_{sp}} \quad \dots (1)$$

where τ_{sp} is the average life time in the excited level.

The number of photons generated will be proportional to the population of the excited level only and can be expressed as

$$R_{sp} = A_{21} N_2 \quad \dots (2)$$

where A_{21} is known as the Einstein coefficient for spontaneous emission. It is a function of frequency and properties of material. It indicates the probability of spontaneous transition from level 2 to 1. It may be noted that the spontaneous emission is independent of the light energy.

Comparing eqns (1) and (2) we get

$$A_{21} = \frac{1}{\tau_{sp}} \quad \dots (3)$$

or
$$\tau_{sp} = \frac{1}{A_{21}}$$

i.e., The reciprocal of probability of spontaneous emission gives the life time. Life time is the average time for which the excited atom would remain in the upper level before undergoing spontaneous transition. It may also be noted that the rate of spontaneous transitions from E_1 to E_2 is zero.

i.e., $A_{12} = 0$

Characteristics of spontaneous emission

- (i) This process is probabilistic in nature, hence cannot control from outside.
- (ii) The instant of transition, direction of propagation, the initial phase and polarisation of each photon are all random.
- (iii) The light resulting through this process is not monochromatic.
- (iv) The light intensity goes on decreasing with distance from the source. This is because different atoms emit photons in different directions.
- (v) It is due to the superposition of waves of random phase, light emitted is incoherent.

Stimulated emission

An atom in the excited state need not wait for spontaneous emission of photon. Suppose a photon of energy $h\nu = E_2 - E_1$ interacts with an excited atom at the energy level E_2 before its spontaneous emission take place. Then the excited atom at energy level E_2 makes a downward transition to energy level E_1 by releasing two photons each of energy $h\nu$. This process is called stimulated emission. Thus the phenomenon of forced photon emission by an excited atom due to the action of external agency is called stimulated emission or induced emission.

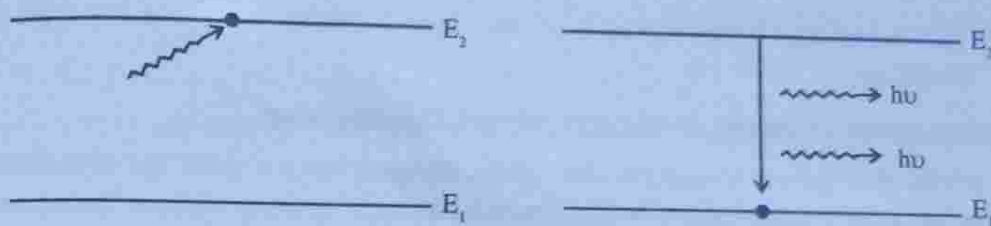

Figure 6.4

The process may be represented as



The probability that a stimulated transition occurs is given by

$$(p_{21})_{st} \propto u(\nu) \text{ or } (p_{21})_{st} = B_{21}u(\nu)$$

The rate of stimulated emission is given by

$$R_{st} = B_{21} u(\nu) N_2$$

where B_{21} is the Einstein coefficient for stimulated emission. It indicates the probability of stimulated emission transition from level 2 to level 1.

Characteristics of stimulated emission

- (i) This process is controllable from outside.
- (ii) The photon induced in this process propagates in the same direction as that of stimulating photon.
- (iii) The inducing photon and the induced photon are identical in frequency, phase and plane of polarisation.
- (iv) In this process photons get multiplied. One photon interacting with an excited atom, two photons are produced. These two photons travelling in the same direction interact with two more excited atoms, totally four photons are produced.

The process continues and get large number of photons like avalanche like manner.

- (v) All the light waves generated in the medium are due to one initial wave and all of the waves are in phase. Thus the waves are coherent and interfere constructively. It results in light amplification.
- (vi) The net intensity of light emitted will be proportional to the square of atoms radiating light. Thus

$$I_{\text{total}} = N^2 I$$

This means that light emitted is of very high intensity so we can say light is amplified.

Spontaneous emission dominates stimulated emission

All the three processes namely absorption, spontaneous emission and stimulated emission occur simultaneously in a medium, when light interacts with medium (matter). Under steady state condition the absorption and the emission processes balance each other.

Thus, $R_{\text{abs}} = R_{\text{sp}} + R_{\text{st}}$

i.e., $B_{12} u(\nu) N_1 = A_{21} N_2 + B_{21} u(\nu) N_2 \quad \dots (4)$

If we consider a medium in thermal equilibrium. In this condition there are more number of atoms in the lower level than the higher level. That is $N_1 \gg N_2$. Since the probability for absorption transition (B_{12}) is equal to the probability for stimulated transition (B_{21}), a photon travelling through the medium is more likely to get absorbed than to stimulate an excited atom to emit a photon. Therefore, usually the process of absorption dominates the process of stimulated emission. Similarly, an atom that is at the excited state is more likely to jump to the lower level on its own than being stimulated by a photon. It is due to the fact that the photon density in the incident beam is not sufficient to interact with the excited atoms and the photons interact with atoms at lower level because of the large population available at that level. Owing to this, the spontaneous emission dominates the stimulated emission.

Einstein coefficients

- (i) We found that the probability that an absorption transition is given by

$$P_{12} \propto u(\nu)$$

i.e., $P_{12} = B_{12} u(\nu)$

The constant of proportionality is known as the Einstein coefficient for induced absorption. It is a constant characteristic of the atom and represents the properties of the energy states E_1 and E_2 .

(ii) The probability that a spontaneous transition is given by

$$(P_{21})_{sp} = A_{21}$$

where A_{21} is a constant known as Einstein coefficient for spontaneous emission. A_{21} is a constant characteristic of the atom and is known as the radiative rate.

$\frac{1}{A_{21}}$ is the life time of the upper state against spontaneous decay to the lower state.

(iii) The probability that a stimulated transition occurs is given by

$$(P_{21})_{st} \propto u(\nu)$$

or

$$(P_{21})_{st} = B_{21}u(\nu)$$

where B_{21} is the constant of proportionality known as the Einstein coefficient for stimulated emission. It is a constant characteristic of the atom and represents the properties of the states E_1 and E_2 .

Note: The spontaneous transition from the state E_1 to E_2 is forbidden by quantum mechanics $A_{12} = 0$.

Relation between Einstein coefficients

Consider an assembly of atoms in thermal equilibrium at temperature with radiation of frequency ν and energy density $u(\nu)$. Let N_1 and N_2 be the number of atoms in energy levels 1 and 2 respectively at any instant. At thermal equilibrium N_1 and N_2 in their levels must remain constant. The condition required that the number of transitions from E_2 to E_1 must be equal to the number of transitions from E_1 to E_2 . Thus

The number of atoms absorbing photons
per second per unit volume = The number of atoms emitting photons
per second per unit volume

The number of atoms absorbing photons
per second per unit volume = $B_{12} u(\nu) N_1$

The number of atoms emitting photons
per second per unit volume = $A_{21} N_2 + B_{21} u(\nu) N_2$

So in equilibrium, we have

$$B_{12}u(\nu)N_1 = A_{21}N_2 + B_{21}u(\nu)N_2$$

or
$$B_{12}u(\nu)N_1 - B_{21}u(\nu)N_2 = A_{21}N_2$$

$$u(\nu)(B_{12}N_1 - B_{21}N_2) = A_{21}N_2$$

$$u(\nu) = \frac{A_{21}}{B_{12}N_1 - B_{21}N_2}$$

$$u(\nu) = \frac{A_{21}N_2}{B_{12}\frac{N_1}{N_2} - B_{21}}$$

$$u(\nu) = \frac{\frac{A_{21}}{B_{12}}}{\frac{N_1}{N_2} - \frac{B_{21}}{B_{12}}}$$

According to Boltzmann's distribution law, we have

$$\frac{N_1}{N_2} = e^{\frac{-(E_2 - E_1)}{kT}} = e^{\frac{h\nu}{kT}}$$

$$\therefore u(\nu) = \frac{\frac{A_{21}}{B_{12}}}{e^{\frac{h\nu}{kT}} - \frac{B_{21}}{B_{12}}} \quad \text{..... (1)}$$

According to Planck's radiation formula we have

$$u(\nu) = \frac{8\pi h\nu^3}{c^3} \frac{1}{\left(e^{\frac{h\nu}{kT}} - 1\right)} \quad \text{..... (2)}$$

Comparing eqns (1) and (2) we get

$$\frac{A_{21}}{B_{12}} = \frac{8\pi h\nu^3}{c^3} \quad \text{..... (3)}$$

and
$$\frac{B_{21}}{B_{12}} = 1$$

or
$$B_{21} = B_{12} \quad \dots (4)$$

Equations 3 and 4 are known as Einsteins relations.

Equation (3) says that the ratio of coefficients of spontaneous emission to the coefficient of stimulated emission is proportional to ν^3 . It means that the probability of spontaneous emission dominates over stimulated emission more and more as the energy difference between two levels ($h\nu$) increases. This is why it is difficult to achieve laser action in higher frequency ranges such as X-rays.

Equation (4) says that the coefficients for both absorption and stimulated emission are equal. i.e., the probability of absorption transition is same as the probability of stimulated emission transition. This implies that when an atom with two energy levels is placed in a radiation field, the probability for an upward (absorption) transition is equal to the probability for a downward (stimulated emission) transition.

Light amplification

We found that when medium is in thermal equilibrium spontaneous emission dominates the stimulated emission. Light amplification requires that stimulated emission occur almost exclusively. In practice, absorption and spontaneous emission always occur together with stimulated emission. The laser operation is achieved when stimulated emission exceeds the other two processes extensively, we shall see under what conditions this criterion is met with.

Condition for stimulated transition to dominate over both spontaneous and absorption transition

For the laser action to take place the existence of stimulated emission is essential. In practice, the absorption and spontaneous emissions always occur together with stimulated emission. Here we shall see under what conditions the number of stimulated emissions can be made larger than the other two processes. The ratio of stimulated transitions to spontaneous transitions is given by

$$R_1 = \frac{\text{Stimulated transitions}}{\text{Spontaneous transitions}} = \frac{B_{21}u(\nu)N_2}{A_{21}N_2}$$

i.e.,
$$R_1 = \frac{B_{21}u(\nu)}{A_{21}}$$

For the stimulated emission transition to be large R_1 must be large i.e., $\frac{B_{21}}{A_{21}}$ must be large and $u(\nu)$ must be large. The ratio of stimulated transitions to absorption transitions is given by

$$R_2 = \frac{\text{Stimulated transitions}}{\text{Absorption transitions}}$$

$$R_2 = \frac{B_{21}u(\nu)N_2}{B_{12}u(\nu)N_1} = \frac{N_2}{N_1}$$

For the stimulated transition to be large R_2 must be large ($R_2 \gg 1$)

i.e., $\frac{N_2}{N_1} \gg 1$

or $N_2 \gg N_1$

i.e., the population N_2 of the excited state should be larger than the population N_1 of the lower energy level.

The above discussion shows that to make stimulated transitions overwhelm the other transitions, three conditions are to be satisfied.

- (i) The population at excited level should be greater than at the lower energy level
- (ii) The ratio $\frac{B_{21}}{A_{21}}$ should be large.
- (iii) The radiation density $u(\nu)$ present in the medium must be high.

When these three conditions are satisfied a medium amplifies light.

Our next aim is to see how to achieve the three above said conditions. The first condition ($N_2 > N_1$) can be met by a mechanism called population inversion. The

second condition $\left(\frac{B_{21}}{A_{21}} \text{ is larger}\right)$ is achieved by choosing a metastable energy level as the higher energy level. This is because, spontaneous transitions are forbidden from metastable state, then $\frac{B_{21}}{A_{21}}$ will be larger. To achieve the third condition

($u(\nu)$ is higher) enclose the emitted radiation in an optical resonant cavity formed by two parallel mirrors. The radiation is reflected many times till the photon density ($u(\nu)$) reaches to a very high value. Now we will see the three above said mechanisms in detail.

Population inversion

When an atomic system is in thermal equilibrium, photon absorption and emission processes take place side by side. Since $N_1 > N_2$, absorption dominates. For laser more stimulated emission than absorption, a majority of atoms should be at the higher energy level than at the lower level. Through some mechanism we can make the number of atoms in the excited level very much greater than that in the ground level. i.e., $N_2 > N_1$. This is a non-equilibrium condition and is known as inverted population condition. This state of the medium is known as the population inversion. Thus population inversion is the non-equilibrium state of the material in which population of the higher energy level N_2 exceeds the population of the lower energy level N_1 .

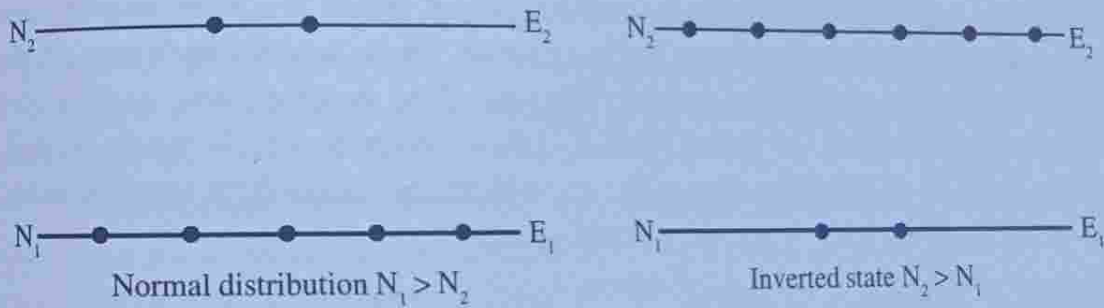

Figure 6.5

Extending the Boltzmann's distribution law

$$\frac{N_2}{N_1} = e^{-\frac{(E_2 - E_1)}{kT}} = e^{-\frac{h\nu}{kT}}$$

To this non equilibrium state of population inversion, it is seen that N_2 can exceed N_1 only if the temperature were negative. In view of this, the state of population inversion is sometimes referred to as a negative temperature state. It does not mean that we can attain temperatures below absolute zero. This happens because the state of population inversion is a non-equilibrium state and the law is not applicable to this. It should be borne in mind that the population inversion state is attained at normal temperatures.

Meta stable state

Population inversion can be achieved through pumping. Since the life time of excited atoms is 10^{-8} s, they release their energy through spontaneous emission. It means that atoms cannot stay in the excited state for a long time. i.e., population inversion cannot be achieved. In order to achieve population inversion atoms have to wait in the excited state till a large number of atoms accumulate in that level. In other words population inversion can be achieved in an excited state which has a longer life time. Such a state is called metastable state.

The metastable state has lifetime of the order of 10^{-6} to 10^{-3} s. Metastable state is necessary for laser action.

Componentes of laser

The essential components of a laser are (i) an active medium (ii) a pumping agent and (iii) an optical resonator.

Active medium

Atoms in general are characterised by a large number of energy levels. However, all types of atoms are not suitable for laser operation. Even in a medium consisting of different species of atoms, only a small fraction of atoms of a particular species are suitable for stimulated emission and laser action. Those atoms which cause light amplification are called active centres. The rest of the medium acts as host and supports active medium. An active medium is thus a medium which, when excited, reaches the state of population inversion, and eventually causes light amplification. The active medium may be a solid, a liquid or a gas.

Pump

For achieving population inversion we have to transfer atoms from the lower energy level to the upper energy level. For this energy must be supplied to the medium. This process of supplying energy to the medium to achieve population inversion is called pumping. There are several methods of pumping. They are optical pumping, electrical pumping, direct conversion are some of them.

Optical pumping

In optical pumping a light source such as a flash discharge tube is used to illuminate the laser medium and the photons of appropriate frequency excite the atoms to an upper most level. From there, they drop to the metastable upper laser level to create the state of population inversion.

Optical pumping sources are flash discharge tubes, continuously operating lamps, spark gaps or an auxiliary laser is sometimes used as the pump source.

Optical pumping is suitable for any laser medium which is transparent to pump light. Optical pumping is used for solid state crystalline lasers and liquid tunable dye lasers.

Electrical pumping

Electrical pumping can be used only in case of laser materials that can conduct electricity. This method is limited to gases. In case of a gas laser, a high voltage pulse initially ionises the gas so that it conducts electricity. An electric current flowing through the gas excites atoms to the excited level from where they drop to the metastable upper laser level leading to population inversion.

Direct conversion

In semiconductor lasers, a direct conversion of electrical energy into light energy takes place. Here it is not the atoms that are excited. It is the current carriers namely electrons and holes which are excited and a population inversion is achieved in the junction region. The electrons recombine with holes in the junction regions producing laser light.

Optical resonant cavity

Laser is an amplified light source. In electronics signals are amplified by an oscillator with positive feedback. A mechanism similar to this is required to amplify light. In laser the active medium is the amplifying medium. This medium is converted into an oscillator through feedback mechanism established by a device called an optical resonator.

For the medium to act as an oscillator, a part of the output energy must be feedback into the system. Such a feedback is brought about by placing the active medium between a pair of mirrors which are facing each other. The mirrors could be either plane or curved. Such a system formed by a pair of mirrors is referred to as a resonator.

If the mirrors used are plane, it is called a plane parallel resonator. A plane parallel resonator consisting of a pair of plane mirrors facing each other. The active medium is placed inside the cavity. This constitutes an optical resonant cavity.

One of the mirrors is fully reflecting and reflects all the light that is incident on it. The other mirror is made partially reflecting such that 90% of incident light is reflected from it and a small fraction is transmitted through it as the laser beam.

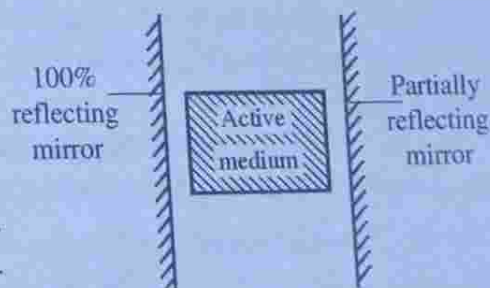

Figure 6.6 : Optical resonant cavity

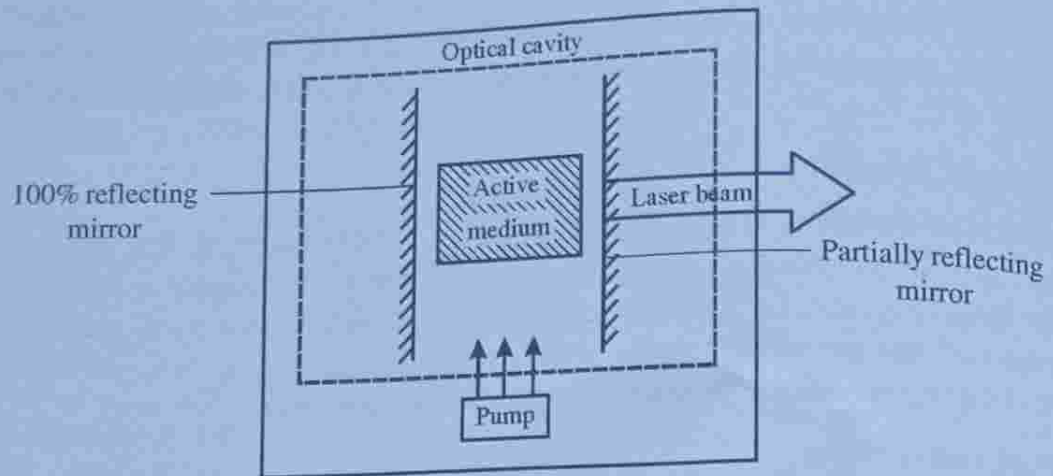

Figure 6.7 : Laser components

Lasing action

Initially, the active centres in the medium are in the ground state. Through suitable pumping mechanism the medium is taken into the state of population inversion, i.e., the excited states are more populated than the ground state. Now some of the excited atoms emit photons spontaneously in various directions. Each spontaneous photon can trigger many stimulated transitions along the direction of its propagation. The photons stimulated travel in different directions since the cause of it travel in different directions. Many such photons leave the medium without reinforcing their strength, resulting in incoherent light. However the presence of mirror impose a specific direction on photons. Photons travelling along the axis are amplified through stimulated emission while photons emitted in any other direction will pass through the sides of the medium and lost for ever. Thus a specific direction is selected for further amplification.

It is due to photons back and forth reflection between the mirrors large number of times, stimulated emission increases sharply there by achieving light amplification.

Since the mirrors provide a feedback of light into the medium, the stimulated emission acts are sustained and the medium operates as an oscillator. At each reflection at the front mirror light is partially transmitted through it. Owing to this energy losses from the resonator. This loss of energy and that from the medium will overwhelmed by the increase in the stimulated emission, laser oscillations buildup. Finally a steady and strong laser beam will emerge from the front mirror.

As the front mirrors reflect light into the medium, energy density of light $u(\nu)$ is large in the medium. See also the the figure below.

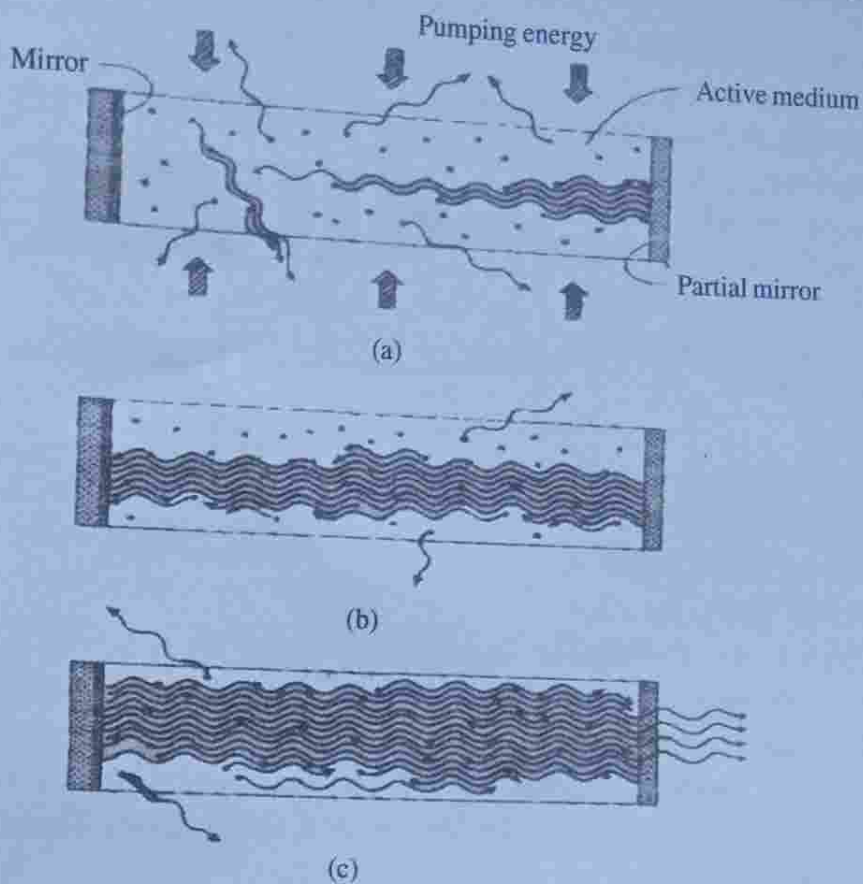

Figure 6.8 : Lasing action

Types of lasers

There are several ways of classifying lasers. We here prefer to classify the lasers on the basis of the material medium used. Accordingly they are divided into four (i) solid state lasers (ii) gas lasers (iii) liquid lasers and (iv) semiconductor diode lasers.

Ruby laser : (A solid state laser)

Theodore Maiman of U.S.A in 1960 fabricated the first laser using a ruby crystal. The ruby crystal rod is a crystal of aluminium oxide doped with chromium ions at a concentration of about 0.05% by weight.

Construction

The ruby laser consists of a cylindrical crystal rod of ruby of about 4cm in length and 0.5cm in diameter whose ends are flat and one of which is completely silvered and the other partially silvered. The silvered ends thus form a resonant cavity. The ruby rod is placed inside a helical photographic flash lamp filled with xenon called

xenon lamp. The xenon flash lamp is connected to a capacitor which discharges a few thousand joules of energy in a few milliseconds. This results in a power output of a few megawatts. The flash lamp acts as the optical pumping system.

Working

When the flash lamp is switched on, xenon discharge generates an intense burst of white light lasting for a few milliseconds. The Cr^{3+} ions are excited to the energy bands E_1 and E_2 by the blue and green components of white light. The energy levels in these bands have a very small life time ($\approx 10^{-9}\text{s}$). Hence the excited Cr^{3+} ions undergo non radiative transitions and drop to the metastable state M. The metastable state is having a life time of nearly 1000 times more than the life time of E_1 and E_2 levels. Therefore Cr^{3+} ions accumulate at M level. When more than half of the Cr^{3+} ion population accumulates at E_2 level, the population inversion is achieved between states M and G (ground state). A chance photon emitted spontaneously by a Cr^{3+} ions initiates a chain of

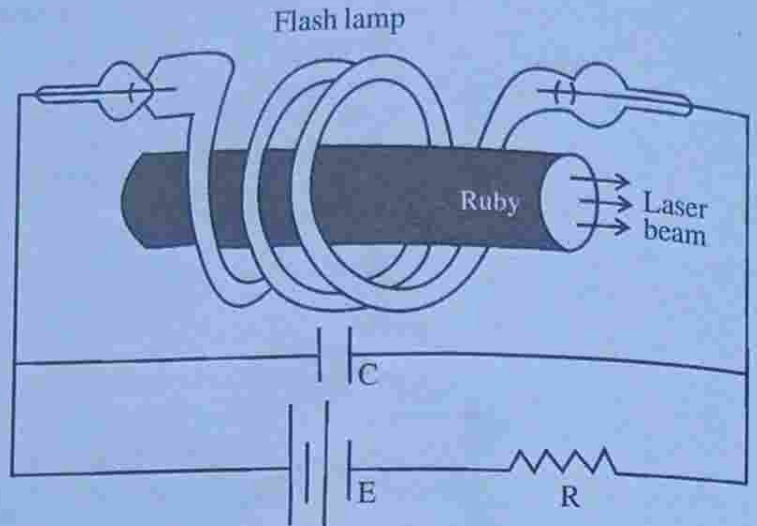

Figure 6.9

photons. The Cr^{3+} ions are excited to the energy bands E_1 and E_2 by the blue and green components of white light. The energy levels in these bands have a very small life time ($\approx 10^{-9}\text{s}$). Hence the excited Cr^{3+} ions undergo non radiative transitions and drop to the metastable state M. The metastable state is having a life time of nearly 1000 times more than the life time of E_1 and E_2 levels. Therefore Cr^{3+} ions accumulate at M level. When more than half of the Cr^{3+} ion population accumulates at E_2 level, the population inversion is achieved between states M and G (ground state). A chance photon emitted spontaneously by a Cr^{3+} ions initiates a chain of

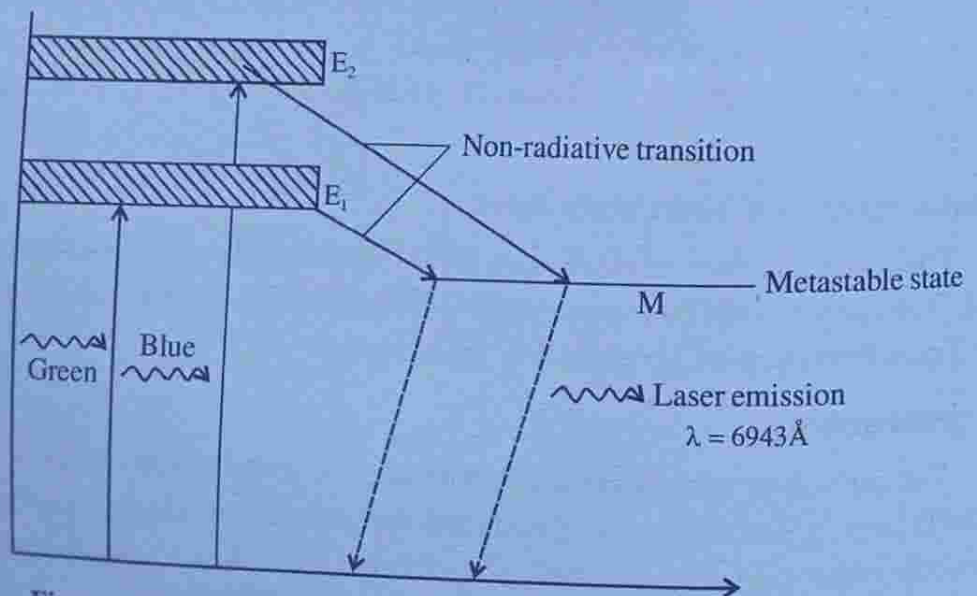

Figure 6.10: Energy levels and transitions in a ruby laser

stimulated emissions by Cr^{3+} ions in the metastable state. Red photons of wave length 6943\AA travelling along the axis of the ruby rod are repeatedly reflected at the end mirrors and light amplification takes place. A strong intense beam of red light emerges out of the front end mirror.

Helium-Neon Laser

Ali Javan and his co-workers in Bell Telephone Laboratories in USA fabricated the first gas laser in 1961. A mixture of helium and neon was taken as the laser medium and electric discharge was used for optical pumping.

Construction

The helium-neon laser consists of along and narrow discharge tube of length 80 cm and diameter 1cm is filled with a mixture of helium and neon in the ratio 10:1. The gas mixture of helium and neon forms the lasing medium and this mixture is enclosed between a set of mirrors forming a resonant cavity. One of the mirrors is completely reflecting and the other is partially reflecting so as to take out the laser beam. The discharge tube is filled with electrodes to provide discharge in the gas. The electrodes are connected to high voltage (10kV) power supply.

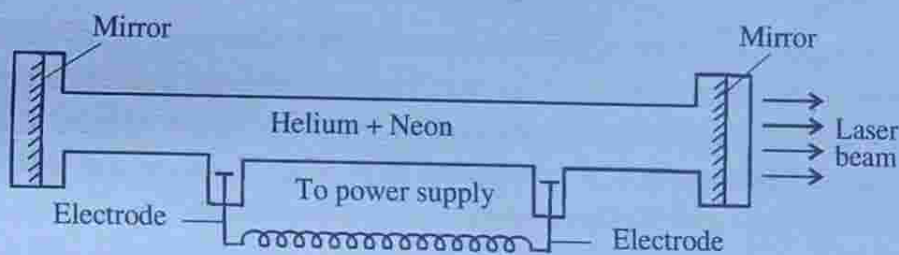

Figure 6.11

Working

When the power is switched on, discharge takes place inside the tube. The electrons and ions produced in the process of discharge are accelerated towards the respective electrodes. The energetic electrons collide with the helium atoms and excite them to higher energy levels F_2 and F_3 . These levels happens to be metastable and hence they stay therefore a long time. i.e. excited atoms cannot return to the ground level through spontaneous emission. However it can return to the ground level by transferring its excess energy to a neon atom through collision. As a result neon atoms are excited to the levels E_4 and E_6 which have approximately the same energy as that of F_2 and F_3 of helium. Thus the discharge through the gas mixture continuously populates the neon excited energy levels E_4 and E_6 . E_4 and E_6 are metastable states. This helps to create a state of population inversion between the level

E_6 (or E_4) and the lower energy level E_5 (or E_3). The various transitions (see figure) lead to emission at wavelengths of $3.39\mu\text{m}$, $1.15\mu\text{m}$ and 6328\AA . The first two correspond to infrared region while the last one corresponds to red light. Specific frequency selection may be obtained by employing mirrors which reflect only a small band of frequencies about the frequency of interest.

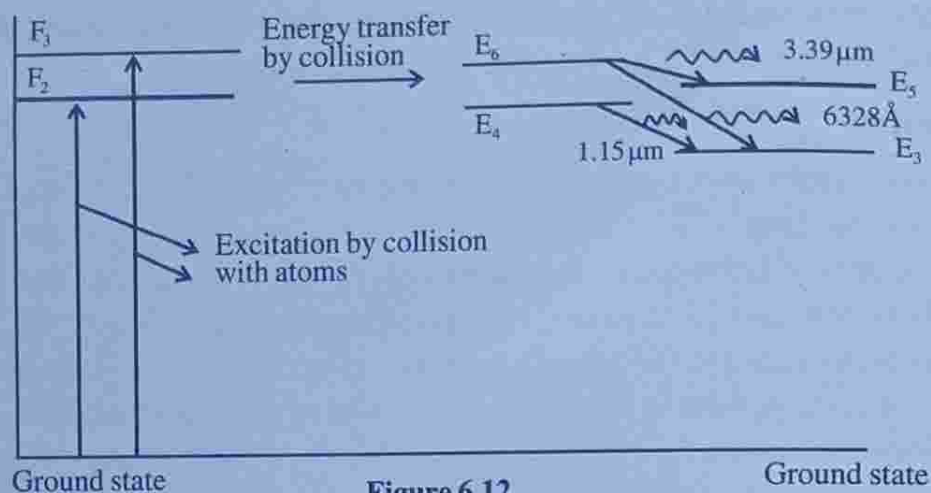

Figure 6.12

The typical power output of helium-neon lasers lie between 1 and 50 mW. The gas lasers are more directional and more monochromatic compared to that of solid state lasers. The gas lasers can supply continuous laser beam without the need for elaborate cooling arrangement. One disadvantage of gas lasers is that the mirrors are usually eroded by the gas discharge and have to be replaced.

Semiconductor laser

The first semiconductor laser was fabricated by R.N Hall and his coworkers in 1962. *A semiconductor diode laser is a specially fabricated PN junction device, which emits coherent light when forward biased.*

How to achieve population inversion in semiconductors

Population inversion is required for producing stimulated emission. A semiconductor consists of electrons and holes distributed in respective energy bands. Therefore the laser action in semiconductors involves energy bands rather than discrete levels. In other lasers population inversion is obtained by exciting electrons in spatially isolated atoms. In semiconductors, electrons are not associated with specific atoms but are injected into the conduction band from the external circuit. Therefore, the conduction band plays the role of excited level while the valence band plays the role of ground level. Population inversion required the presence of a large concen-

tration of electrons in the conduction band and a large concentration of holes in the valence band. A simple way to achieve population inversion is to use a semiconductor in the form of a PN junction diode formed from heavily doped P and N type semiconductors.

Construction

A diode laser consists of a heavily doped P-N junction. Starting with a heavily doped N type GaAs material, a P-region is formed on its top by diffusing Zinc atoms into it. A heavily Zinc doped layer constitutes the heavily doped P-region. The top and bottom faces are metallized and metal contacts are provided to pass current through the diode. The front and rear faces are polished parallel to each other and perpendicular to the plane of the junction. The polished faces serve as optical cavity. In practice there is no need to polish the faces. A pair of parallel planes cleared at the two ends of the PN junction provides the required reflection to form cavity. The two remaining sides of the diode are roughened to eliminate lasing action in that direction. The entire structure is packed in small case which looks like the metal case.

Working

When the P-N junction is forward biased, electron and holes are injected into the junction region in high concentrations. At low forward current level, the electron hole recombination causes spontaneous emission of photons and the junction acts as an LED. As the forward current through the junction is increased the intensity of the light increases linearly. However, when the current reaches a threshold value, the carrier concentrations in the junction region will rise to a very high value. As a result the junction region contains a large concentration of electrons within the conduction band and simultaneously a large number of holes within the valence band. Hole represent absence of electrons. Thus the upper energy level in the narrow region are having a high electron population while the lower energy levels in the same region are vacant. Therefore, the condition of population inversion is attained in the narrow junction region.

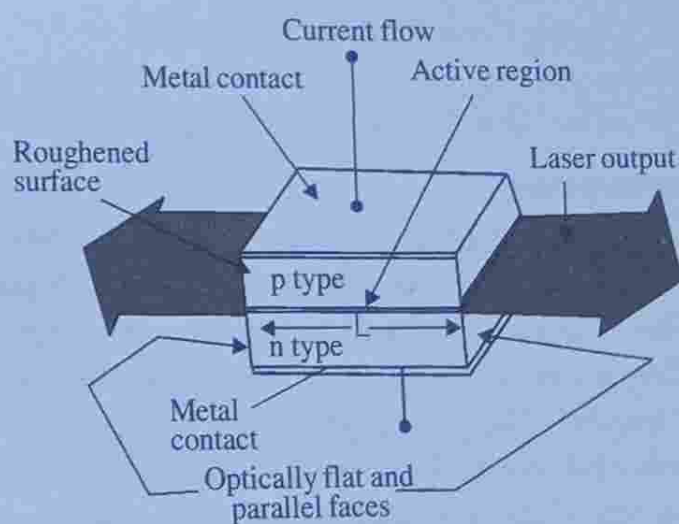

Figure 6.13

This narrow zone in which population inversion occurs is called an inversion region or active region. Chance recombination acts of electron and hole pairs lead to emission of spontaneous photons. The spontaneous photons propagating in the junction plane stimulate the conduction electron to jump into the vacant states of valence band. This stimulated electron hole recombination produces coherent radiation. GaAs laser emits light at a wavelength of 9000\AA in IR region

Advantages of diode laser

- (i) It is operated at low temperature
- (ii) PN junction lasers are made to emit light almost anywhere in the spectrum from UV to IR
- (iii) They are remarkably small in sizes (0.1mm long)
- (iv) They have high efficiency of the order of 40%
- (v) They operate at low powers
- (vi) It is portable
- (vii) They produce high power output
- (viii) Their costs are cheap

Uses

The diode lasers are mass produced for use in optical fibre communications, in CD players, CD-ROM drivers, optical reading, high speed laser printing etc.

YAG laser

Yttrium Aluminium Garnet (YAG) crystal is doped with neodymium (Nd) ion, we get a laser medium. When doped in YAG, Nd^{+3} ions take the place of yttrium ions. Doping Concentrations are typically of the order of 0.725% by weight which corresponds to about 1.4×10^{26} atoms per cubic metre. These lasers are four level systems and therefore require lower pump energies than the ruby laser.

Construction

It consists of a laser rod (Nd : YAG) about 10cm in length and a diameter of 12 mm. The YAG rod and a linear flash lamp are housed in a reflector cavity of elliptical cross section. The light issuing from the lamp is closely coupled to the laser rod as they are located at the foci of the ellipse. The ends of the YAG rod are ground flat and parallel. The optical cavity may be formed by silvering the ends of the rod. In practice two external mirrors are used as shown in figure. One mirror is made 100% reflecting while the output mirror is about 90% reflecting. The system is cooled by circulating air.

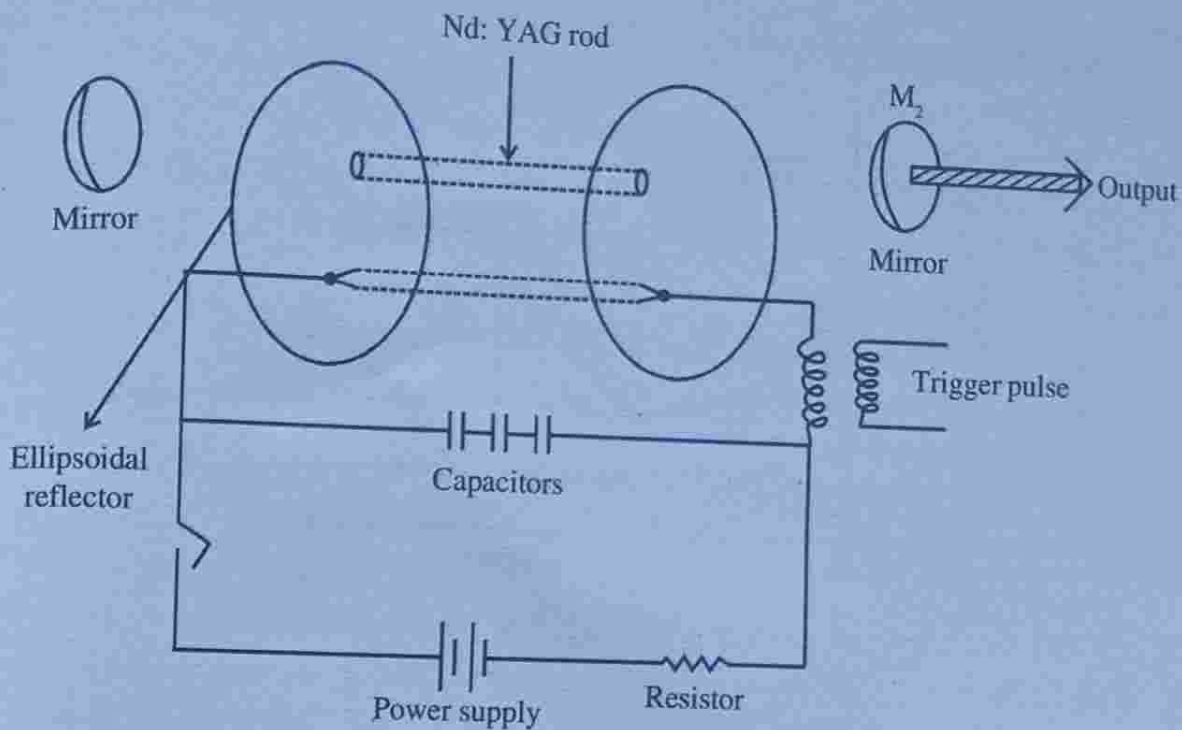

Figure 6.14

Working

It is a four level laser system. Here pumping is achieved by using an intense flash of white light from a xenon flash lamp. It excites Nd^{3+} ions from the ground state to the multiple energy state at E_4 . The excited Nd^{3+} ions quickly decay to the metastable level E_3 , releasing their excess energy to the crystal lattice. As the lower laser level E_2 is located at 0.25 eV above the ground state E_1 , it cannot be populated by Nd^{3+} ions through thermal transitions from the ground level. The population inversion can be readily achieved between E_3 and E_2 levels. In the E_3 level, Nd^{3+} ions are stimulated to emit on the main $1.064\mu\text{m}$ laser transition and drop to the lower laser level E_2 . From the level E_2 , Nd^{3+} ions quickly drop to the ground state again by transferring energy to the crystal. The output power of the laser is about 1kW. The wavelength of this laser lies in the infra red. It is possible to double the frequency by second harmonic generation. Therefore, through a harmonic generator to the system, this laser can be made to produce green light at a wavelength of 5320\AA .

Characteristics of Laser beam

The important characteristics of a laser beam are

- 1) directionality
- 2) negligible divergence

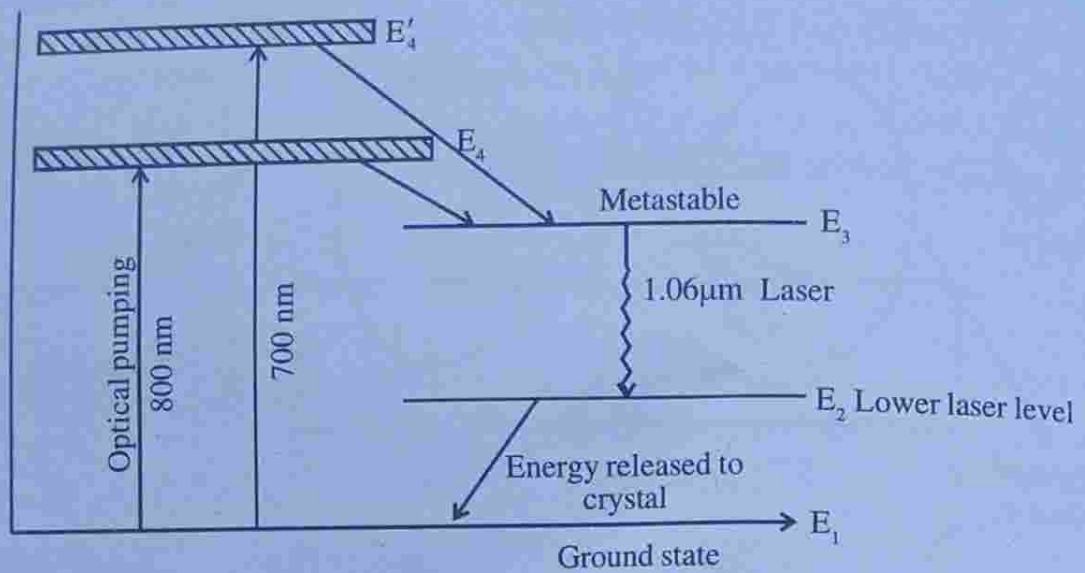

Figure 6.15

- 3) high intensity
- 4) high degree of coherence and
- 5) high degree of monochromaticity.

1) Directionality

The conventional light sources emit light in all directions. To have a beam in one direction source is placed before a narrow slit. The laser beam emits only in one direction called directionality.

2) Divergence

Light from conventional sources spread out in the form of spherical waves, hence it is divergent. Laser propagates in the form of plane waves. So divergence is very small. For example a typical He-Ne laser diverges about only 10^{-3} radian.

3) Intensity

The intensity of a conventional source of light decreases with distance. But the intensity of laser beam is almost a constant. Laser beam is highly intense.

4) Coherence

Conventional source of light is incoherent whereas laser light is highly coherent. For example light from a sodium lamp has a coherence length of 0.3mm where as coherence length of a typical He-Ne laser is about 100m.

5) Monochromaticity

When a light source has only one frequency (single wavelength) is called monochromatic and the source is called monochromatic source. Conventional monochro-

matic source spreads over a wavelength of 100\AA to 1000\AA whereas laser beam spreads over a narrow range less than 10\AA , so we say that laser sources are highly monochromatic.

Applications of laser

Lasers find applications in almost every field. They are used in mechanical working, industrial electronics, entertain electronics, communications, information processing and even in wars to guide missiles to the target. Lasers are used in CD players, laser printers, laser copiers, optical floppy discs, optical memory cards etc. Lasers are also used in medical field. It is used as a tool for surgical operations especially in ophthalmology and dermatology. Here we discuss only some of them.

(i) Welding

Welding is the process of joining two or more pieces into a single piece. If we consider welding of two metal plates, the metal plates are held in contact at their edges and a laser beam is made to move along the line of contact of the plates. The laser beam heats the edges of the two plates to their metal point and causes them to fuse together and become a single piece when the laser beam is removed. The main advantage of the laser is that it is a contact-less process and there is no possibility of introduction of impurities into the joint. In the process, the work pieces do not get disturbed, as the total amount of input is very small compared to conventional welding process. The heat effected zone is relatively small because of rapid cooling. Laser welding can be done even at a place difficult to reach. CO_2 lasers are used in welding thin sheets and foils.

Drilling

The principle of drilling is the vapourisation of metal at the focus of the laser beam. One can drill holes of diameter less than $10\mu\text{m}$. For drilling, the energy must be supplied in such a way that rapid evaporation of material takes place without significant radial diffusion of heat into the work piece. The vapourised material is removed with the help of a gas jet. Pulsed ruby and neodymium lasers are commonly used for this. CO_2 lasers also used for drilling and cutting. This laser system is commonly used to drill and cut not only metals but also nonmetals such as ceramics, plastics, cloth, paper, glass and so on.

(ii) Hardening

Lasers are used to harden metals and other materials. Heat treatment is the process for this. Heat treating converts the surface layer to a crystalline state that is harder and more resistance to wear. Heat treatment is common in the tooling and automotive industry. It is used to strengthen cylinder blocks, gears, camshafts etc. in

the automobile industry. Usually CO_2 laser with 1kW output power is used for heat treatment.

(iii) Electronic industry

Lasers are used in the manufacture of electronic components and integrated circuits. Lasers have been used to perforate and divide silicon slices having several hundred circuits. They are also used for the isolation of faulty components in a large integrated circuit by disconnecting the conducting paths by evaporation. Trimming of thick and thin film resistors using lasers is a very common application.

(iv) Medical field

Surgeons use lasers to burn up brain tumours and tattoos. Lasers are also used in the treatment of paralysis. He-Ne laser is used to stimulate the nerves in the wrists and ankles. This is also used to stimulate the part of the brain that controls motor responses and causes dramatic change in nerve reactions.

In ophthalmology surgeons now a days use lasers to treat severe glaucoma patients. In dermatology surgeons use lasers to remove skin irregularities, warts, pimples and deep-red birthmarks.

Raman effect

When a beam of monochromatic light of frequency ν_0 is incident on dust free transparent liquids such as benzene, toluene, carbon tetra chloride etc. most of it is transmitted without change and some of it is scattered with a pair of frequencies of the type $\nu = \nu_0 \pm \nu_m$, where ν_m is the characteristic frequency of molecular system. This kind of scattered radiation with change of frequency is called Raman scattering and the phenomenon is called Raman effect.

Raman experiment and Raman spectrum

The original arrangement used by Raman was very simple in design. A round bottomed glass flask was filled with dust free organic liquid and the liquid strongly illuminated by 4358.3\AA line from a mercury arc lamp, suitably filtered and concentrated by a lens. The scattered light was examined by means of a spectroscope placed in a direction perpendicular to that of the incident radiation. In the spectrum of scattered light, a number of new lines were observed on both sides of the main line. This is called the Raman spectrum. See the spectral profiles of Raman spectrum below. Raman spectrum consists of three types of lines or bands.

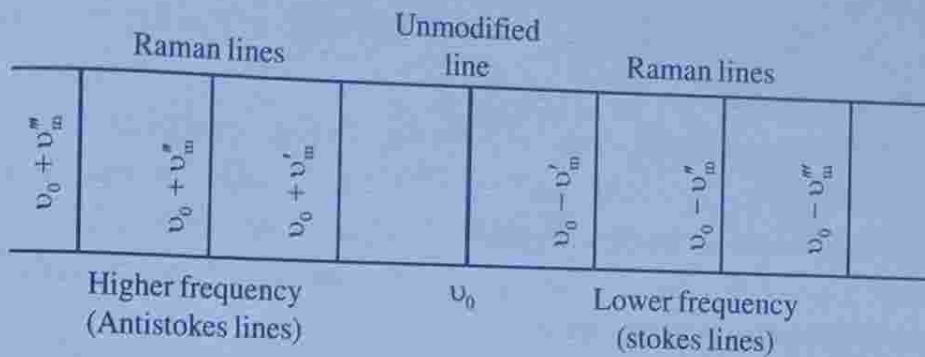

Figure 6.16: Profile of the Raman spectrum

1. Unmodified lines

This line occurs with no change in frequency from that of the illuminating line and corresponds to frequency ν_0 . The frequency value of this line depends on the nature of the source used to irradiate the sample. It is a very intense line and lies exactly at the centre of the Raman spectrum about which the other Raman lines are symmetrically distributed.

2. Stokes lines

These corresponds to modified frequency bands which occur on the lower frequency side of the spectrum. The lines on this side are more numerous and more intense than those on the higher frequency side. These lines are indicated as $\nu_0 - \nu_m$ in the figure.

3. Antistokes lines

The lines indicated by $\nu_0 + \nu_m$ on the left side of the figure are called antistokes lines. They are less intense and less numerous when compared to the stokes lines. Owing to the gradual decline in intensity of these lines as we move away from the unmodified (ν_0) line in many instances it was not possible to detect as many lines as there are stokes lines in the Raman spectrum.

The new frequencies $\nu = \nu_0 \pm \nu_m$ in the spectrum of scattered radiation are called Raman lines including ν_0 . Another important aspect of the Raman spectrum is that most of these new lines are strongly polarised and their spacing is symmetrical about the main line ν_0 .

The original Raman experiment conducted by Raman consisted of dust free CCl_4 and the monochromatic incident source used for irradiation was mercury arc lamp with wavelength 4358.3\AA or wave number $\frac{1}{\lambda} = \bar{\nu} = 22,938\text{cm}^{-1}$. The Raman spectrum obtained on a photographic plate after a very long irradiation period, contained

one intense band at $\bar{\nu}_0 = 22,938\text{cm}^{-1}$ due to Rayleigh scattering and a number of weak bands at $\bar{\nu}_0 \pm 218$, $\nu_0 \pm 314$, $\bar{\nu}_0 \pm 459$, $\bar{\nu}_0 - 762$, $\bar{\nu}_0 - 790\text{cm}^{-1}$. The first three pairs of bands were easily detectable on the photographic plate. Only the Stokes lines corresponding to $\bar{\nu}_0 - 762$ and $\nu_0 - 790\text{cm}^{-1}$ could be seen as very weak bands where their corresponding anti-Stokes lines were not observed. However, with the availability of laser sources, Raman spectra are now being recorded in lesser time and with greater intensity bands.

Raman scattering versus Rayleigh scattering

Scattering of radiation without any change in frequency had been known earlier to the discovery of Raman effect. In general, scattering of radiation without any change in frequency can occur from very large scatterers like dust particles and such phenomenon was called Mie scattering. However, when a similar scattering occurs with molecules which are smaller than the wavelength of the incident radiation, it is called Rayleigh scattering, after its discoverer, Lord Rayleigh. In the Raman scattering a set of new discrete frequencies were observed when the scatterer was a molecule like in Rayleigh scattering. In Rayleigh scattering no frequency change takes place and only the existing frequencies appear. But in Raman scattering new lines of different frequencies were observed through a single incident frequency. Thus Rayleigh scattering always accompanies Raman scattering. Also, in the Rayleigh scattering although there is no resultant change in the energy state of the molecular system, the system will participate directly in the scattering act. This process causes one photon of incident radiation to be annihilated and a photon of the same energy to be created simultaneously. The intensity of Rayleigh lines is generally about 10^{-3} of the intensity of the incident line, whereas the intensity of the strong Raman line is about 10^{-3} of the intensity of Rayleigh line.

Classical theory of Raman effect

This theory leads to an understanding of the vital concept, the molecular polarizability, though the theory is not fully adequate. When a molecule is placed in a static electric field it suffers some distortion, the positively charged nuclei being attracted towards the negative of the field, the electrons to the positive of the field. This separation of charge centres causes an induced electric dipole moment to set up in the molecule and the molecule is said to be polarized. The magnitude of the induced dipole moment (μ_i) depends on the magnitude of the applied field (E) and on the ease with which the molecule can be polarized. Thus we have

$$\mu_i = \alpha E \quad \dots (1)$$

where α is the polarizability of the molecule.

Consider a diatomic molecule H_2 placed in an electric field (E) in two ways one perpendicular (end on or called equatorial) to the direction of the electric field other one along the direction of electric field as shown in figure.

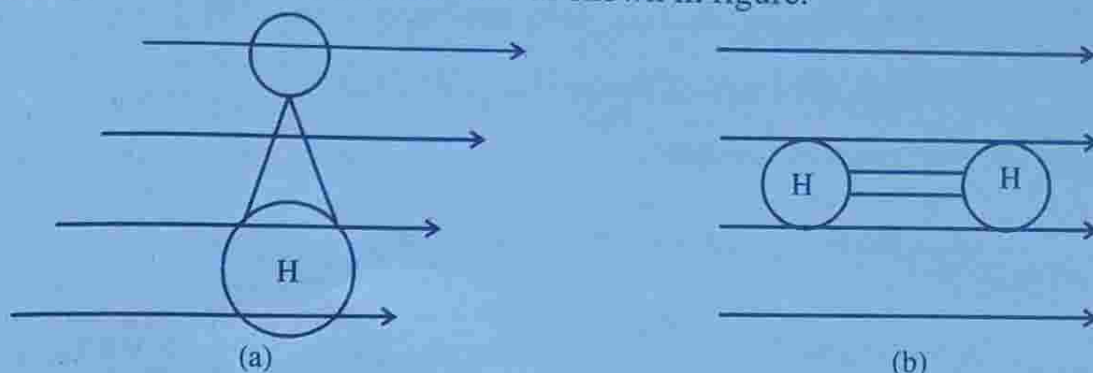

Figure 6.17

It is seen that the electrons forming the bond are more easily displaced by the field along the bond axis (figure b) than across the bond (figure a). Thus the polarizability is said to be anisotropic. Experimentally it has been found that the induced dipole moment for a given field applied along the axis is approximately twice as large as that induced by the same field across the axis. The fields in other directions induce intermediate dipole moments.

Theory

When a polarized molecule is subjected to a beam of monochromatic radiation of frequency ν , the electric field experienced by each molecule varies according to the equation

$$E = E_0 \sin 2\pi\nu t$$

\therefore The induced dipole moment becomes

$$\mu_i = \alpha E = \alpha E_0 \sin 2\pi\nu t$$

This equation shows that the induced dipole oscillates with a frequency ν . We know that an oscillating dipole emits radiation corresponding to the frequency of oscillation. This is the unshifted scattering of the incident radiation which gives the explanation of Rayleigh scattering.

In addition, if the molecular system undergoes some type of periodic internal motion, such as vibration or rotation, this may change the polarizability of the molecule periodically. Then the oscillating dipole will have superimposed upon it the vibrational or rotational oscillation. Consider, for example, a vibration of frequency ν_{vib} which changes the polarizability. We can write

$$\alpha = \alpha_0 + \beta \sin 2\pi\nu_{\text{vib}} t$$

where α_0 is the equilibrium polarizability and β is the rate of change of polarizability with the vibration. Thus we have

$$\mu_i = \alpha E = (\alpha_0 + \beta \sin 2\pi\nu_{\text{vib}} t) E_0 \sin 2\pi\nu t$$

$$\mu_i = \alpha_0 E_0 \sin 2\pi\nu t + \beta E_0 \sin 2\pi\nu_{\text{vib}} t \sin 2\pi\nu t$$

Using the trigonometric relation

$$\sin A \sin B = \frac{1}{2} [\cos(A - B) - \cos(A + B)]$$

$$\mu_i = \alpha_0 E_0 \sin 2\pi\nu t + \frac{\beta E_0}{2} \cos 2\pi(\nu - \nu_{\text{vib}})t - \frac{\beta E_0}{2} \cos 2\pi(\nu + \nu_{\text{vib}})t$$

This equation shows that the oscillating dipole has frequency ν , $\nu - \nu_{\text{vib}}$ and $\nu + \nu_{\text{vib}}$.

If $\beta = 0$ in the above equation the dipole oscillates only at the frequency of the incident radiation. This shows that in order to have Raman lines $\beta \neq 0$. i.e., a molecular vibration must cause some change in a component of molecular polarizability (α). This is also true for molecular rotation.

The above discussion shows that the prerequisite to the Raman effect is the occurrence of a periodic internal motion accompanied by the corresponding polarizability change. The change in polarizability can either be magnitudinal or directional. Hence both the rotational and vibrational motions of the molecule may give rise to Raman effect.

Quantum theory of Raman effect

According to quantum theory, Raman effect involves the interaction of a molecule with a beam of monochromatic radiation of frequency ν_0 and in the process the molecule is excited to quantised upper state.

This interaction leads to three situations.

- (i) The molecule might merely deviate the photon ($E = h\nu_0$) without absorbing its energy. This would result in the appearance of the unmodified line in the scattered radiation.
- (ii) The molecule, on the other hand, might absorb a part of the energy of the incident photon. This gives rise modified Raman lines called Stokes lines whose frequencies would be less than that of the incident radiation.
- (iii) Also it may happen that the molecule, itself being in an excited state, imparts some of its intrinsic energy to the incoming photon. This would result in the appearance of anti-Stokes lines whose frequencies are greater than that of the incident radiation.

If the interaction of incident photon and the molecule is imagined as a collision process, the unmodified line is a result of elastic collision and the other Raman lines are due to inelastic collisions. Therefore mechanism of Raman scattering can be analytically expressed by applying the principle of conservation of energy. We can thus write.

$$E_0 + \frac{1}{2}mv^2 + h\nu_0 = E' + \frac{1}{2}mv'^2 + h\nu'$$

where E_0 and E' are the intrinsic energies and v and v' are the velocities of molecules before and after collision respectively. m is the mass of the molecule, where as ν_0 and ν' are the frequencies of incident and scattered radiation. Since the collision does not, generally, result in any rise in temperature, it may be fairly assumed that the kinetic energy of the molecule remains practically unaltered. In view of this, the above equation becomes

$$E_0 + h\nu_0 = E' + h\nu'$$

or
$$\nu' = \nu_0 + \frac{(E_0 - E')}{h} = \nu_0 + \frac{\Delta E}{h}$$

where $E_0 - E' = \Delta E$

If $E_0 = E'$ (no change in intrinsic energies due to collision process).

$$\therefore \nu' = \nu_0$$

This represents the unmodified line. If $E_0 < E'$ (inelastic collision resulting in the gain of intrinsic energy of the molecule and a loss of energy of the scattered photon).

$$\therefore E_0 - E' = -\Delta E$$

$$\text{Thus } \nu' = \nu_0 - \frac{\Delta E}{h}$$

This represents the frequencies of stokes lines.

If $E_0 > E'$ (inelastic collision resulting in the loss of intrinsic energy of the molecule) $E_0 - E' = \Delta E$

$$\text{Thus } \nu' = \nu_0 + \frac{\Delta E}{h}$$

This represents the frequencies of antistokes lines.

IMPORTANT FORMULAE

1. Frequency of emission or absorption radiation.

$$\nu = \frac{E_2 - E_1}{h}$$

2. Expression for relative population of atoms:

$$N_2 = N_1 e^{\frac{-(E_2 - E_1)}{kT}}$$

3. Rate of absorption transition:

$$R_{\text{abs}} = -\frac{dN_1}{dt} = \frac{dN_2}{dt}$$

$$R_{\text{abs}} = B_{12} u(\nu) N_1$$

4. Rate of spontaneous transition:

$$R_{\text{sp}} = -\frac{dN_2}{dt} = \frac{N_2}{\tau_{\text{sp}}}$$

$$R_{\text{sp}} = A_{21} N_2$$

5. Rate of stimulated transition:

$$R_{\text{st}} = B_{21} u(\nu) N_2$$

6. Relation between Einstein's coefficients

$$(i) \frac{A_{21}}{B_{12}} = \frac{8\pi h \nu^3}{c^3}$$

$$(ii) B_{21} = B_{12}$$

7. Condition for population inversion

$$N_2 \gg N_1$$

8. Condition for stimulated transition dominate over both spontaneous and absorption radiation

$$(i) N_2 > N_1$$

$$(ii) \frac{B_{21}}{A_1} \text{ is larger}$$

$$(iii) u(\nu) \text{ must be high.}$$

UNIVERSITY MODEL QUESTIONS

Section A

(Answer questions in two or three sentences)

Short answer type questions

1. What is laser? What are its properties?
2. Give three applications of laser.
3. What are Einstein coefficients? Define them.
4. Write down Boltzmann's distribution law for population of energy levels and explain the symbols?
5. What is population inversion? What is the condition to achieve it?
6. What are the conditions to be satisfied to have large stimulated emission?
7. What is meant by pumping? What are the different types of it?
8. Explain what is a metastable state.
9. What is an active medium?
10. What are the essential components of a laser. Explain their functions.
11. In He – Ne laser, lasing is through neon gas. What is then the role of helium?
12. What is the reason for monochromaticity of laser beam.
13. What are the advantages of diode laser?
14. What are the uses of diode lasers?
15. Draw the labelled diagram of a ruby laser.
16. Draw the labelled diagram of a He – Ne laser.
17. Draw the labelled diagram of a diode laser.
18. Draw the labelled diagram of a YAG laser.
19. What is the active centre in a YAG laser? Explain its function.
20. What is Raman effect?
21. What are stokes and antistokes lines?
22. Distinguish between stokes lines and antistokes lines.
23. Distinguish between Raman scattering and Rayleigh scattering.
24. Why stokes lines are more intense than antistokes lines?
25. According to the classical theory what is the prerequisite to the Raman effect.

Section B

(Answer questions in a paragraph of about half a page to one page)

Paragraph / problem

1. Explain the quantum behaviour of light.
2. Explain how does light interact with matter.

3. What is meant by induced absorption? Explain with a two level diagram.
4. What is meant by spontaneous emission? Explain with a two level diagram.
5. How does Einstein predicted stimulated emission of radiation.
6. Explain the stimulated emission of radiation with a two level diagram.
7. Show that $A_{21} = \frac{1}{\tau_{sp}}$ and $A_{12} = 0$.
8. What are the characteristics of spontaneous emission.
9. What are the characteristics of stimulated emission
10. Spontaneous emission dominates over stimulated emission. Explain.
11. Explain the process of light amplification.
12. Briefly explain optical pumping.
13. Briefly explain electrical pumping.
14. How population inversion is achieved in semiconductor lasers.
15. Explain the function of optical resonator.
16. Briefly explain lasing action.
17. Explain in brief the lasing action of a laser.
18. Describe the working of solid state ruby laser.
19. Describe the working of He – Ne laser.
20. Describe the working of semiconductor laser.
21. Describe the working of YAG laser.
22. Briefly explain the experimental design of Raman effect.
23. Raman lines are symmetrically distributed about the unmodified line. Explain.
24. Explain the unmodified line of Raman spectrum quantum mechanically.
25. Explain the formation of stokes lines on the basis of quantum mechanics.
26. Explain the formation of antistokes lines on the basis of quantum mechanics.
27. Explain the quantum theory of Raman effect.
28. The He – Ne system is capable of lasing at $3.3913\mu\text{m}$. Determine the energy difference in eV between the upper and lower levels of this wave length. [0.365 eV]
29. The energy level difference between two laser level is 0.21 eV. Determine the wavelength of radiation. [5.9 μm]
30. In a ruby laser, the ruby rod contains a total of 3×10^{19} chromium ions. If laser emits light of 6943\AA wavelength, find the energy of one emitted photon and the total energy available per laser. [1.79 eV, 8.6 J]
31. Find the relative atomic population of first excited state and ground state of hydrogen gas at room temperature. [2.5×10^{-9}]

32. Find the relative population of the two states in a ruby laser that produces a light beam of wavelength 6943\AA at 500 K. [8.7×10^{-19}]
33. The wavelength of emission is 6000\AA and the life time τ_{sp} is 10^{-6} s. Determine the coefficient for stimulated emission [$B_{21} = 1.3 \times 10^{19} \text{ mkg}^{-1}$]
34. At what temperature are the rates of spontaneous and stimulated emission equal. Assume $\lambda = 5000\text{\AA}$. [41,573 K]
35. At what wavelength are the rates of spontaneous and stimulated emission equal at temperature 300K. [69.8 μm]

Section C

(Answer questions in about one to two pages)

Long answer type questions-Essays

1. What are Einstein's coefficients? Derive a relation between them.
2. Describe the principle, construction and working of a ruby laser.
3. Explain the principle, construction and working of a He - Ne laser.
4. Explain the principle, construction and working of a semiconductor laser.
5. Explain the principle, construction and working of a YAG laser.
6. Explain the classical theory and quantum theory of Raman effect.

Hints to problems

1 to 30 - see book work

$$31. \quad E_2 - E_1 = h\nu = \frac{hc}{\lambda} = \frac{6.6 \times 10^{-34} \times 3 \times 10^8}{3.3913 \mu\text{m}} \text{ J}$$

$$= \frac{6.6 \times 10^{-34} \times 3 \times 10^8}{3.3913 \times 10^{-6} \times 1.6 \times 10^{-19}} = 0.365 \text{ eV}$$

$$32. \quad E_2 - E_1 = \frac{hc}{\lambda}$$

$$0.21 \times 1.6 \times 10^{-19} = \frac{6.62 \times 10^{-34} \times 3 \times 10^8}{\lambda}, \text{ Find } \lambda.$$

$$33. \quad E_2 - E_1 = \frac{hc}{\lambda} = \frac{6.62 \times 10^{-34} \times 3 \times 10^8}{6943 \times 10^{-10} \times 1.6 \times 10^{-19}} \text{ eV}$$

Energy per pulse = Energy of one photon \times Total number of atoms.

$$= 1.79 \times 1.6 \times 10^{-19} \times 3 \times 10^{19} \text{ J}$$

$$34. \quad \frac{N_2}{N_1} = e^{\frac{-(E_2 - E_1)}{kT}}$$

For the hydrogen atom $E_1 = -13.6\text{eV}$

and $E_2 = -3.39\text{eV}$

$$\therefore E_2 - E_1 = 10.21\text{eV}, \quad k = 1.38 \times 10^{-23} \text{JK}^{-1}$$

$$T = 27^\circ\text{C} = 300\text{K}$$

Calculate $\frac{N_2}{N_1}$

$$35. \quad E_2 - E_1 = \frac{hc}{\lambda} = 1.79\text{eV}$$

$$\frac{N_2}{N_1} = e^{\frac{-(E_2 - E_1)}{kT}}$$

Find $\frac{N_2}{N_1}$ by assuming k

$$T = 500\text{K}$$

$$36. \quad B_{21} = \frac{A_{21} c^3}{8\pi h \nu^3} = \frac{A_{21} \lambda^3}{8\pi h}$$

$$\text{where } A_{21} = \frac{1}{\tau_{sp}} = 10^6$$

$$37. \quad B_{21} u(\nu) = A_{21}$$

$$\text{i.e., } \frac{1}{\frac{h\nu}{e^{kT}} - 1} = 1$$

$$\nu = \frac{c}{\lambda} = \frac{3 \times 10^8}{5 \times 10^{-7}} = 6 \times 10^{14} \text{ T} = ?$$

Assuming h and k , find T

38. When stimulated and spontaneous emission are equal, we have

$$\frac{1}{\frac{h\nu}{e^{kT}} - 1} = 1$$

Putting the values of h , k and T , find ν .

$$\text{Then use } \lambda = \frac{c}{\nu}.$$
